

REQUEST FOR PROPOSALS

Electrical Services Procurement

FOR CAPITAL IMPROVEMENT TO U.S. BANK STADIUM IN MINNEAPOLIS, MINNESOTA

April 4, 2019

A. Project Background and Objectives

In 2012, the State of Minnesota enacted 2012 Minnesota Laws, Chapter 299 (the “Act”), to establish the Minnesota Sports Facilities Authority (“Authority”) and to provide for the construction, financing, and long-term use of a new stadium now known as U.S. Bank Stadium (the “Stadium”) and related stadium infrastructure (the “Stadium Infrastructure”) as a venue for professional football and a broad range of other civic, community, athletic, educational, cultural and commercial activities.

As set forth in the Act, the Authority may make capital improvements to design, development and construction of the Stadium and the Stadium Infrastructure, and the certain capital improvements that that Authority is soliciting in this Request for Quotations (“RFQ”) shall be referred to in this RFQ as the “Project”. To that end, the Authority has prepared this RFQ for the Electrical Services. Those who respond to this RFQ shall be referred to as “Proposers”.

The Project is located at the Stadium [and other additional adjacent land that has been acquired by the Authority in Minneapolis, Minnesota]. The Specification Documents identifying and indicating the scope of the Project are also incorporated within this RFQ as **Exhibit 1**. The Specifications Documents meet the standards required for a National Football League (“NFL”) franchise, as well as additional standards established by the Authority. The Project must be completed by June 30, 2019 at the latest (the “Required Completion Date”).

B. Scope of Services: The successful Proposer to the RFP will be engaged in providing electrical services and accessible power and technology connects for equipment in Minneapolis Cocktail stand, Rusty Taco stand, Pizza stand, and the 1st and Fry concession stand (as further described in the RFP and any addenda that will be issued to this RFP) including, without limitation:

- Acquire all permits and conform to locate and State codes.
- Design, provide, install, hook up, coordinate, test, and inspect all items required to complete the work associated with the Project. This includes receiving, inspecting, uncrating, and removal/disposal of packing material. Clean-up of all work areas is required as part of this scope

- All necessary tools, equipment and components (cords, connections, fasteners, etc.) as needed to provide a turnkey installation and delivery of the Project.
- Provide testing and commissioning of system(s).
- All premium (overtime) hours required to meet the Project schedule and scope, not including time added due to Owner revisions/additions.
- One-year on-site warranty to repair or replace the work and services constituting the project.

C. Intent and Process of the Request for Proposals

This RFP is focused on the selection of Proposer that will provide the best value to the Authority in the [design, coordination, supply, construction, installation, commissioning, and testing] of the Project.

Proposers should have significant experience in the electrical field similar to the Project that is the subject of this RFP. It is the desire of the Authority to consider as part of its selection criteria the commitment of the Proposer to exert good faith efforts to comply with the plan of the Authority to ensure equitable opportunities for Minority Owned Business Enterprises (“MBE”) and Women Owned Business Enterprises (“WBE”) to participate in the Project. The successful Proposer or Proposers must also demonstrate the ability to exert good faith efforts to comply with workforce goals and targeted zip code hiring goals, and work with organizations to develop effective MBE, WBE and workforce recruitment efforts during the preconstruction, design, construction management, and the construction of the POS System for the Project. The Authority has developed an Equity Plan for this Project available [on its web site or as an attachment to this RFP], and as described below, each Proposer should provide a plan describing how they will encourage the participation and utilization of appropriate workforce, MBEs and WBEs in the Proposers’ performance of their services. MBEs and WBEs that are interested in acting as the Proposers for the Project are encouraged to respond to the RFP.

D. Requested Qualifications

The Authority reserves the right and discretion to determine the qualifications and responsibility of the Proposers to perform the work and services that are the subject of the RFP. It is the request and intent of the Authority that Proposers responding to the RFP have the following qualifications.

- Significant experience in the design, coordination, supply, installation, and testing of projects similar to the Project that is the subject of this RFP.
- Experience in the design, coordination, supply, installation, and testing of a similar project.

- In-house capacity to produce necessary selection, construction, and schedule documentation, which does not preclude any Proposer from also identifying potential sub-consultants that could assist in producing such estimates and schedules.
- Performance and payment bond bonding capacity or ability to obtain bonding capacity to the full amount of the selected scope of the Project System contained within the submitted Proposal.

E. RFP Timeline

Advertise and issue Request for Proposals	April 4, 2019
Pre-proposal Site Visits	

In lieu of a Proposal Conference, SMG staff will schedule individual times for each interested bidder to do a site walk through. Times are by appointment only and must be scheduled through Curtis Schmillen (contact information above).

Site Walk Through Visit Dates are available by appointment only.

Written Questions Due	April 17, 2019
Proposals Due	April 19, 2019
Project Completion	June 30, 2019

By submitting a Proposal, the Proposer affirms that this timeline must and can be met to avoid the potential for significant harm to the progress of the Project and to the interests of the Authority and public.

F.1 Proposer Qualifications

The following items shall be included in a Proposal executive summary:

- Proposer’s name and address of office that would have central responsibility for the work. Identify the business form of Proposer and list the principal shareholders or other business owners. If the proposed form of entity is a joint venture, please identify each joint venture participant and their respective percentage of participation. Provide a summary, on three pages or less, describing why the Proposer is the most qualified to be the Provider for the Project.
- Provide copies of Proposer’s certificates of insurance showing Proposer’s current total limits of liability for commercial general liability, worker’s compensation, employer’s liability, business automobile liability, and professional liability.
- Provide representative list of similar projects managed by Proposer during that last 10 years or that are currently under construction or management. Include:
 - Project name.

- Project location.
 - Contracting or ownership entity.
 - Project description; listing dates of construction, seating capacity, project gross square footage, and wireless environment cost. Proposers shall be specific about which projects have been worked on by current employees while employed by your firm vs. those that were worked on while employees of another employer. List key principal of Proposer who was responsible for the project.
 - Key contact or reference from project Owner including name, title, email, and telephone number.
- Provide evidence of Proposer's capacity to provide or obtain performance and payment bonds in a letter from Proposer's bonding company listing Proposer's single project bonding capacity or limit. If Proposer is a joint venture, describe the joint venture's plan to provide bonding capacity.
 - Complete and submit a fully executed confidentiality agreement
 - Submit response to State of Minnesota "Affirmative Action Data" form and "Statement of Non-Collusion".
 - Submit your proposals for the exhibits listed below to the draft Trade Contractor Agreement, which Proposer should anticipate it will likely become exhibits to the final, executed Trade Contract should the Proposal be accepted. In addition to being attached to the Trade Contractor Agreement, these exhibits are also directly attached to this Request for Proposals in order to bring them to Proposers' direct attention. In their Proposals, Proposers' should label these proposed exhibits using the exhibit numbers set forth below.
 - Exhibit 1 – Description of Trade Contractor Work. Proposer should provide its proposed form of Exhibit 1 and should indicate any proposed changes to the terms provided by the Authority by including both a red-lined and clean versions of its proposed version.
 - Exhibit 2 – Trade Contract Amount. In addition to providing the itemized pricing information requested below in Section F.2, Proposer should provide its proposed version of Exhibit 2.
 - Exhibit 3 – Targeted Business Commitment and Information Form.
 - Exhibit 4 – Targeted Business Information Form.
 - Exhibit 5 – TCA Equity Plan Progress Report.

- Exhibit 6 – Construction Schedule. Proposer should provide its proposed version of Exhibit 6.
- Exhibit 7 – Bonds. The Authority has provided its form for the required payment and performance bonds. As part of providing information regarding its bonding capacity, Proposer should indicate whether it has any proposed changes to the Authority’s forms. If Proposer has any proposed revisions, it should include both a red-lined and a clean version of its proposed version in its Proposal.
- Exhibit 8 – Warranty. The Authority has provided its form for the required warranty. If Proposer has any proposed revisions, it should include both red-lined and clean versions of its proposed version in its Proposal.
- If Proposer has any other proposed revisions to the Trade Contractor Agreement (Exhibit A), it should include both red-lined and clean versions of its proposed version in its Proposal.

F.2 Submittal Requirements: Evaluation of Proposals

Proposers shall include the following items in their Proposal. As described below, the Authority will score Proposals on a point system, with some criteria being graded on a pass-fail basis. Proposers who fail any criterion may have their Proposal rejected. A total of 1,600 points will be available as follows:

Project Delivery:	500 points
Technical Specifications:	500 points
Commercial Terms:	500 points
Interview:	100 points
Equitable Contracting and Hiring:	Pass/Fail

The Proposals receiving the highest three scores, as determined by the Authority in its sole discretion, will then be short-listed and selected to enter into final discussions and negotiations with the Authority, as a result of which the Authority will select in its discretion the Proposer whose final Proposal is most advantageous and the best value to the Authority as permitted by the Act.

Project Delivery – 500 Points

1. Similar Project Experience. Describe Proposer’s experience with design-build projects and discuss Proposer’s view as to appropriate ways to proceed with the requirements for this Project.

2. Project Personnel. Provide names and resumes of key personnel who would be directly responsible for the work. Provide key contact telephone, fax, and email addresses. Provide organizational chart listing proposed team members by name and responsibility. Indicate other projects to which team members are assigned currently for years 2018 to 2019. Any other relevant experience pertinent to the requirements for this Project shall be listed under "Other Significant Experience."
3. Project Specific Risks and Solutions. Identify and describe the risks Proposer perceives as being significant for the scope of services required by this RFP, and how Proposer intends to mitigate, manage, and control those risks.
4. Project Controls. Describe Proposer's approach and methodology for implementing project controls relating to budget and schedule compliance, and provide examples of Proposer's experience in successfully managing similar projects that were completed within the established budget and schedule and fulfilled the defined project's program.
5. Preliminary Performance Schedule. Please provide Proposer's preliminary critical path method performance schedule with milestones interdependencies identified for critical items of design, ordering, construction, and installation work that generally demonstrates Proposer's strategy for completing the scope of work required by this RFP by the required deadline. Exhibit 6 shall be evaluated in considering this factor. U.S. Bank Stadium is a very busy venue and coordination with the event schedule is paramount. An event schedule can be provided upon request and the proposed timelines for other contractor/vendor work related to the NCAA Final Four in the Spring of 2019 leading up to the Final Four.

Technical Specifications – 500 Points

Commercial Terms – 500 Points

1. Price. Provide itemized pricing on all necessary [design, coordination, supply, construction, installation, and testing] of a complete Project and all scope of work items required by this RFP, including without limitation:

- All material and equipment;
- All design or design assist services;
- All construction and installation;
- All training and testing;
- Opening event support;

- Warranty for onsite hardware maintenance for first and second year;
- Detailed cost information for ongoing fixed and variable costs, including licenses, hosting fees, customer service, tax calculation service fees, and any cost exclusions;
- Estimate of all other project expenses including travel, shipping, and sales tax (if any); and,
- Proposed form of Exhibit 2.

2. Warranties and Maintenance. A two-year warranty will be requested covering the services and work performed for the Project. Provide copies of the proposed warranties and describe the warranty terms, durations, limitations, etc. [Describe any service and maintenance programs, including copies of all proposed or required service and maintenance contracts and fees.] Any proposed revisions to Exhibit 8 shall be considered in evaluating this factor.

3. Agreement to or Requested Revisions to Trade Contract Agreement (Exhibit A) Contract Terms. The extent to which revisions are requested to the Authority's proposed contract in this RFP will be given point deductions in the sole discretion of the Authority. Any proposed revisions to Exhibit 1 shall be considered in evaluating this factor.

Interview – 100 Points

The Authority will conduct an interview with each qualified Proposer that has submitted a responsive proposal.

Equitable Contracting and Hiring – Pass/Fail

1. Hiring and MBE/WBE Utilization. Describe Proposer's practices and history of hiring women and minorities. Also describe Proposer's specific plan to reach targeted goals for MBE and WBE construction participation on this project, and Proposer's strategies for employing women and members of minority communities to comply with the Authority's Equity Plan. Exhibits 3 to 5 shall be considered in evaluating this factor.

According to the Act, there shall be no disclosure of any information derived from Proposals submitted by competing Proposers and the content of all Proposals is nonpublic data under Chapter 13 of Minnesota Statutes until such time as a notice to award a contract is given by the Authority.

The Authority may change its scoring of Proposals as a result of interviews of and negotiations with Proposers.

A Proposer's response may also contain any narrative, charts, tables, diagrams, or other materials in addition to those called for herein, to the extent such additions are useful for clarity or completeness of the response. Attachments should clearly indicate on each the page the paragraph in the RFP to which they pertain.

The RFP, responses to it, and any subsequent negotiations and discussions shall in no way be deemed to create a binding contract or expectation of an agreement between the Proposer and the Authority.

Each Proposer submitting a Proposal in response to this RFP acknowledges and agrees that the preparation of all materials for submittal to the Authority and all presentation, related costs, and travel expenses are at Proposer's sole expense and that the Authority shall not, under any circumstances, be responsible for any cost or expense incurred by the Proposers, except the payment of the stipend that will be given to those short listed Proposers who properly submit in good faith the preliminary construction estimate and otherwise complete the RFP process. The Authority shall be allowed to keep any and all materials supplied by the Proposers in response to the RFP.

The Authority reserves the right to accept or reject any or all Proposals, to amend or alter the selection process in any way by addendum, to postpone the selection process for its own convenience at any time, and to waive any non-material defects in proposals submitted. Proposals are required to remain open and subject to acceptance until an award is finalized, or a minimum of (90) days following the date of submission of Proposals. The Authority also reserves the right to accept or reject any individual sub-consultants that the successful Proposer proposes to use.

A. Project Labor Agreement

The Authority will require the Proposer to negotiate and enter into an appropriate labor agreement acceptable to the Authority for the Proposer's work required by this RFP.

B. Payment and Performance Bonds

By Minnesota statutes and the Act, payment and performance bonds will be required from the successful Proposer in the amount of 100% of the cost of Proposal.

C. Pre-Proposal Meeting

Pre-proposal site visits will be held by appointment only. If you would like to have a site tour, please contact Curtis Schmillen at cschmillen@usbankstadium.com.

Proposals are due by 5:00 pm. CST, on April 19, 2019. One electronic copy and 3 bound copies of each Proposal should be enclosed in a sealed envelope addressed to:

Minnesota Sports Facilities Authority
Attention: James Farstad
1005 4th Street South
Minneapolis, Minnesota 55415

With an electronic copy sent via email to

Curtis Schmillen at cschmillen@usbankstadium.com
James Farstad at james.farstad@msfa.com
Elizabeth Proeitz at Elizabeth.proeitz@msfa.com

D. Questions or Inquiries

All questions must be submitted via email no later than 5:00 pm. CST, on April 17, 2019 to:

SMG – US Bank Stadium
Curtis Schmillen – cschmillen@usbankstadium.com

MSFA - U.S. Bank Stadium
James Farstad – james.farstad@msfa.com

MSFA-U.S. Bank Stadium
Elizabeth Proeitz - Elizabeth.Proeitz@msfa.com

E. Minnesota Government Data Practices

All Proposals are eventually subject to the Minnesota Government Data Practices Act, Minn. Statutes, Chapter 13, but the Act prohibits disclosure of any information derived from Proposals submitted by competing Proposers, and the content of all Proposals is nonpublic data under Chapter 13 until such time as notice to award a contract to the successful Proposer is given by the Authority. Proposers shall note with their Proposal any data in their Proposal that they consider proprietary information or otherwise private and confidential.

F. Other Exhibits to the RFP

Exhibit A	Trade Contract Agreement
Exhibit B	Confidentiality Agreement – Must be filled out by Proposer
Exhibit C	Non-Collusion Statement – Must be filled out by Proposer
Exhibit D	Minnesota Department of Human Rights Affirmative Action Data Page— Must be filled out by Proposer

- Exhibit E Construction Documents – Must be filled out by Proposer
Exhibit F Acknowledgement and Attestation Form – Must be filled out by Proposer

The following exhibits are associated with the Trade Contract Agreement, and will be required prior to contract approval:

Trade Contract Agreement and Exhibits to Agreement – Proposer must fill out **ALL** of the following forms:

- Exhibit 1 Description of Trade Contract Work
Exhibit 2 Trade Contract Amount
Exhibit 3 Targeted Business Commitment and Information Form
Exhibit 4 Targeted Business Information Form
Exhibit 5 TCA Equity Plan Progress Report
Exhibit 6 Construction Schedule
Exhibit 7 Bonds
Exhibit 8 Warranty
Exhibit 9 Insurance Certificates

EXHIBIT A

Trade Contract Agreement



TRADE CONTRACT AGREEMENT BETWEEN THE MINNESOTA SPORTS FACILITIES AUTHORITY AND THE TRADE CONTRACTOR

TRADE CONTRACT AGREEMENT

THIS TRADE CONTRACT AGREEMENT (“Trade Contract Agreement”) is made as of the [REDACTED] day of [REDACTED] in the year of 20__ (“Effective Date”).

BY AND BETWEEN

The AUTHORITY:

MINNESOTA SPORTS FACILITIES AUTHORITY
1005 4th Street South
Minneapolis, MN 55415

and the

TRADE CONTRACTOR:

For:

For the following **PROJECT:** Stadium and Stadium Infrastructure for U.S. Bank Stadium

1. General Provisions

1.1 Definitions. The definitions set forth in **Attachment A** shall apply in this Trade Contract Agreement.

1.2 Correlation and Intent. It is the intent of the Trade Contractor and Authority that the Trade Contract Documents include all items necessary for proper design, construction, execution and completion of the Trade Contractor Work. The Trade Contract Documents are complementary, and what is required by any one shall be binding as if required by all. Work not covered in the Trade Contract Documents, but reasonably inferable from the Trade Contract Documents, will be included as part of the Trade Contractor Work. In the event of inconsistencies within or between parts of the Trade Contract Documents, or between the Trade Contract Documents and Applicable Laws, the Trade Contractor shall (x) provide the better quality or greater quantity of the Trade Contractor Work or (y) comply with the more stringent requirement, either or both in accordance with the Authority's reasonable interpretation.

1.3 Project Site. Before ordering any materials or doing any Trade Contractor Work, the Trade Contractor shall verify all existing conditions and measurements at the Project Site and shall be responsible for the correctness of such measurements. Any difference that may be found shall be submitted to the Authority for interpretation before proceeding with the Trade Contractor Work. Any errors due to the Trade Contractor's failure to so verify all such dimensions or locations shall be promptly rectified by the Trade Contractor without any additional cost to the Authority.

2. Trade Contractor Work

2.1 Scope of Work. The Trade Contractor shall provide all services, work, labor, materials, equipment and other necessary payments as are required to complete the Trade Contractor Work as set forth in the Trade Contract Documents and as set forth on **Exhibit 1**. The Trade Contractor Work is intended to be inclusive of all design, construction, services, work, labor, materials, engineering, Testing, tools, supplies, facilities, management, supervision, permits, licenses, taxes, inspections and equipment required by, or reasonably inferable from, the Trade Contract Documents necessary to complete the Trade Contractor Work pursuant to the Construction Schedule for the Trade Contract Amount.

2.2 to 2.3 [RESERVED].

2.4 Representation and Warranty. The Trade Contractor warrants and represents the following: (a) the Trade Contract Amount is just and reasonable compensation for all the Trade Contractor Work; (b) said Trade Contract Amount is sufficient to address all foreseen and unforeseen conditions that will impact the Trade Contractor Work and ability to complete the Trade Contractor Work in accordance with the Trade Contract Amount and Contract Time; (c) the Contract Time is adequate for the performance of the Trade Contractor Work; and (d) the Trade Contractor has a complete understanding of the scope of the Trade Contractor Work and has been provided adequate time to establish the Trade Contract Amount in sufficient detail to support the Trade Contract Amount.

2.5 Labor Harmony. The Trade Contractor shall only employ labor in connection with the Trade Contractor Work capable of working harmoniously with all trades, crafts, and any other Persons associated with the Project. The Trade Contractor shall also use its best efforts to minimize the likelihood of any strike, work stoppage, or other labor disturbance.

2.6 to 2.7 [RESERVED].

2.8 Substitutions and Alternates. If, after execution of the Agreement and prior to submittal of applicable Shop Drawings to the Architect and Authority, the Trade Contractor desires to submit an Alternate product in lieu of what has been specified or shown in the Trade Contract Documents, the Trade Contractor may proceed only after receiving written approval from the Authority.

2.9 Permits. The Trade Contractor shall secure, pay for, and, as soon as practicable, furnish the Authority with copies or certificates of all permits and fees, licenses and inspections necessary for the proper execution and completion of the Trade Contractor Work. The Trade Contractor shall deliver certificates of inspection, use, and occupancy to the Authority upon completion of the Trade Contractor Work in sufficient time for occupancy or use of the Trade Contractor Work in accordance with the Construction Schedule and occupancy of the Project in accordance with the Master Project Schedule.

2.10 [RESERVED]

2.11 Trade Contractor's Construction Schedule. The Trade Contractor shall prepare in consultation with the Authority and Architect, and submit for the Authority's review and approval, a Construction Schedule in critical path method format. In no event shall the Authority be responsible for any costs incurred by Trade Contractor due to its responsibility to coordinate its Trade Contractor Work with the normal operation of the Stadium or the work of other trade contractors.

2.12 Shop Drawings, Product Notes and Samples. The Trade Contractor shall perform no portion of the Trade Contractor Work until the associated Shop Drawings, Product Data, Samples, or similar Submittals related to that Trade Contractor Work has been reviewed and approved by the Authority (or if designated by the Authority, by its designee). Such Trade Contractor Work shall be in accordance with approved Submittals.**2.12.1** The Trade Contractor shall not be relieved of responsibility for deviations from requirements of the Trade Contract Agreement by the Authority's (or if designated by the Authority, its designee's) approval of Shop Drawings, Product Data, Samples, or similar Submittals, unless the Trade Contractor has specifically informed the Authority (or if designated by the Authority, its designee) in writing of the existence and nature of such deviation at the time of submittal and the Authority (or if designated by the Authority, its designee) has given written approval to the specific deviation.

2.13 Cutting and Patching. The Trade Contractor shall be responsible for cutting, fitting, or patching required to complete the Trade Contractor Work or to make the Trade Contractor Work fit together properly or any damages caused to other work thereby.

2.14 Cleaning Up. The Trade Contractor shall keep the premises of the Trade Contractor Work and all surrounding areas to the Project Site free of debris or obstructions arising out of the Trade Contractor Work. If the Trade Contractor fails to cleanup as

required, the Authority may, but shall not be obligated to, perform the Trade Contractor's cleanup and charge the cost thereof to Trade Contractor.

2.15 Access to Trade Contractor Work. The Trade Contractor shall provide the Authority, its respective agents and representatives, and Architect access to the Trade Contractor Work in preparation and progress wherever located.

2.16 Means and Methods. In no event shall the Authority or Indemnitees have any responsibility or liability for design or construction means, methods, techniques, sequences, or procedures, or for safety precautions and programs in connection with the Trade Contractor Work, notwithstanding any of the rights and authority granted the Authority and Indemnitees in the Trade Contract Agreement.

3. Design Services.

3.1 Performance and Coordination. The Design Services provided by the Trade Contractor, or through a design professional Consultant that Trade Contractor retains to fulfill its obligations under the Trade Contract Agreement, shall be performed in strict accordance with all provisions of the Act. Trade Contractor shall coordinate and integrate the Design Services with the Architect, and other Trade Contractors and Vendors to allow the Vendors, and Trade Contractors to complete their work.

3.2 Standard of Care. The Design Services provided by Trade Contractor for the design and construction of its Trade Contractor Work shall be provided pursuant to the Standard of Care applicable to professional design services.

4. Contract Time

4.1 Time. The Trade Contractor shall perform the Trade Contractor Work expeditiously, efficiently, and safely in accordance with the Construction Schedule. Trade Contractor shall achieve Substantial Completion of the Trade Contractor Work within the time frames specifically described in Exhibit 4.

4.2 "Substantial Completion" or "Substantially Complete" shall mean the date or dates listed in Exhibit 4 and that the Trade Contractor Work (or separable units or phases as may be agreed to by the Authority) is essentially and satisfactorily complete in accordance with the Trade Contract Documents, such that the Trade Contractor Work is fully commissioned, fully operational, received all required certifications and approvals pursuant to Applicable Law, and will permit beneficial use by the Authority. In no event shall Substantial Completion be deemed to have occurred until any certificates or licenses required from Suppliers for use of the Trade Contractor Work have been delivered to the Authority.

4.3 Punchlist. When the Trade Contractor considers that the Trade Contractor Work, or a portion thereof which the Authority agrees to accept separately, is Substantially Complete, the Trade Contractor shall prepare and submit to the Authority a comprehensive Punchlist of items to be completed or corrected. The Trade Contractor shall proceed promptly to complete and correct items on the Punchlist. Failure to include an item on the Punchlist does not alter the responsibility of the Trade Contractor to complete all Trade Contractor Work in accordance with the Trade Contract Documents. The Authority reserves the right to add to the Punchlist within thirty (30) Days after receipt of an

acceptable Punchlist from the Trade Contractor. If the Authority makes any additions to the Punchlist, the Trade Contractor shall, before issuance of the Certificate of Substantial Completion, complete or correct such item(s). When the Trade Contractor Work or designated portion thereof is Substantially Complete, the Authority will prepare a Certificate of Substantial Completion for execution by the parties.

4.4 Final Completion. Within sixty (60) Days after Substantial Completion, the Trade Contractor shall achieve Final Completion of all Trade Contractor Work. The date of Final Completion shall establish the start of responsibility under the Agreement for security, maintenance, heat, utilities, damage to the Trade Contractor Work, and insurance. Warranties required by the Trade Contract Documents shall commence on the date of Final Completion of the Trade Contractor Work or designated portion thereof. The Certificate of Final Completion shall be submitted to the Authority and the Trade Contractor for their written acceptance of responsibilities assigned to them in such Certificate. Final Completion of the Trade Contractor Work shall not occur until the Trade Contractor submits to the Authority all documentation and certifications in any such form as may be designated by the Authority.

4.5 Force Majeure. If the Trade Contractor is delayed in the progress of the Trade Contractor Work by events of Force Majeure, fire or other property damage not caused by the Trade Contractor or a Subcontractor, Supplier, Sub-subcontractor of any tier, or other Person for whom Trade Contractor is legally responsible, unusually severe weather conditions not customarily encountered in the area surrounding the Project which affect the scheduled Critical Path of the Trade Contractor Work, or any other cause for which the Trade Contractor is not responsible, then the Contract Time, provided for in **Paragraph 4.1** above, shall be extended by a Contract Revision for a reasonable period of time as agreed to by the Authority.

4.6 Contract Time Extensions. Notwithstanding anything to the contrary in this Trade Contract Agreement, the Trade Contractor agrees that, regardless of the cause of delay and whether or not any extension of Contract Time may be granted therefore, Trade Contractor shall continue to prosecute all Trade Contractor Work not directly affected by said cause of delay and, with respect to such portion or portions of the Trade Contractor Work as may be so affected, shall take all reasonable measures to minimize the effect of said cause of delay. All requests for a time extension must be made within twenty-one (21) days of the event allegedly causing the delay. It is a condition precedent to the consideration or prosecution of any Claim for an extension of Contract Time that the foregoing provisions be strictly adhered to in each instance and, if the Trade Contractor fails to comply, Trade Contractor shall be deemed to have waived the Claim to the extent that proper notice or mitigation would have shortened the period of delay. The Trade Contractor further acknowledges and agrees that adjustments in the Contract Time will be permitted for a delay only to the extent such delay (a) is not caused, or could not have been reasonably avoided, by the Trade Contractor, or (b) could not be reasonably limited or avoided by the Trade Contractor's timely notice to the Authority of the delay or reasonable likelihood that a delay will occur.

4.7 [RESERVED].

4.8 Partial Use. The Authority shall have the right to use, without prejudice to rights of either Party, any completed or Substantially Completed portions of the Trade Contractor Work, notwithstanding the fact that time for completion of entire Trade Contractor Work,

or portions thereof, may not be expired. Use by Authority shall not constitute, in itself, acceptance of the Trade Contractor Work.

4.9 to 4.16 [RESERVED]

4.17 Royalties and Patents. The Trade Contractor shall pay all royalties and license fees. The Trade Contractor shall defend suits or claims for infringement of patent rights and shall hold the Authority and all Indemnitees harmless from loss on account thereof.

4.18 Indemnification by Trade Contractor.

4.18.1 To the fullest extent permitted by Applicable Laws, Trade Contractor hereby agrees to indemnify, hold harmless, and defend the Authority and Indemnitees from and against any and all claims, damages, liabilities, losses and expenses (specifically including reasonable attorneys' fees and costs, court fees and costs, and arbitration fees and costs incurred to defend the Authority and Trade Contractor's liability shall not be limited by the amount or limit of insurance Trade Contractor procures to insure its obligations to the Authority or Indemnitees), provided that such claims, damages, losses or expenses arise out of bodily injury, sickness, disease or death, or to injury to or destruction of tangible property (other than the Trade Contractor Work itself), but only to the extent arising out of, resulting from, or incurred in connection with the performance of the Trade Contractor Work and to the extent in whole or in part caused or alleged to have been caused by the negligent or grossly negligent acts or omissions, of the Trade Contractor, Trade Contractor's employees, Subcontractors, Sub-Subcontractors, Suppliers or any Person for whom the Trade Contractor is legally responsible in the performance of the Trade Contractor Work under this Trade Contract Agreement, whether arising before or after completion of the Trade Contractor Work and arising out of, resulting from, or occurring in connection with the performance of the Trade Contractor Work or any activity associated with the Trade Contractor Work, from any activity of the Trade Contractor, Trade Contractor's employees, its Subcontractors, Sub-Subcontractors, Suppliers, their agents, or employees at the Project Site or elsewhere, and whether in part caused by the active or passive negligence or other fault of a Party or Person indemnified hereunder, excepting only personal injury to Persons or damage to property found to have been caused by the sole negligence of a Party or Person indemnified hereunder. Such obligations shall not be construed to negate, abridge, or reduce other rights or obligations of indemnity that would otherwise exist as to a Party or Person described in this **Subparagraph 4.18.1.4.18.2** Trade Contractor acknowledges and agrees that it has an independent obligation under this Trade Contract Agreement to procure and maintain contractual liability coverage insurance as will insure Trade Contractor's obligations in this **Paragraph 4.18**, and further acknowledges that such insurance is commercially available. Trade Contractor's liability shall not be limited by the amount or limit of insurance Trade Contractor procures to insure its obligations herein. Trade Contractor agrees and acknowledges that such contractual liability coverage is for the benefit of the Authority and Indemnitees, but does not require Trade Contractor to provide such insurance directly to the Authority and Indemnitees.

4.18.3 In addition to its duties under **Paragraph 4.18** herein, the Trade Contractor shall defend, indemnify, and hold harmless the Authority and the

Indemnitees from and against any and all alleged claims, damages, liabilities, losses and expenses (specifically including reasonable attorneys' fees and costs, court fees and costs, and arbitration fees and costs incurred to defend the Authority and Indemnitees) caused by Trade Contractor's breach of this Trade Contract Agreement to the extent finally determined. For the purpose of this **Subparagraph 4.18.3**, the Authority's or an Indemnitee's tender shall not be deemed to require proof of the Trade Contractor's breach of contract at the time of tender.

4.18.3 The Trade Contractor shall indemnify the Authority, Indemnitees, and the respective directors, officers, agents, and employees of any of them from and against any and all costs and expenses, specifically including reasonable attorneys' fees and costs, court fees and costs, and arbitration fees and costs, incurred by any of the foregoing Parties or Persons to enforce any of the Trade Contractor's defense, indemnity, and hold-harmless obligations under this Trade Contract Agreement.

4.18.4 The Trade Contractor's obligation to defend as set forth in **Subparagraphs 4.18.1** and **4.18.2** includes the obligation to provide and pay for attorneys to defend the Party or Persons entitled to indemnification under **Subparagraphs 4.18.1** and **4.18.2**, which attorneys shall be subject to the approval of such Party and Persons; and if such Party or Persons do not approve the attorneys provided by the Trade Contractor, the Trade Contractor shall promptly pay the attorneys' fees incurred by the Party or Persons entitled to indemnification

5. Trade Contract Amount

5.1 The Trade Contract Amount shall be as set forth on **Exhibit 2**.

6. Record Retention, Audit and Claims

6.1 The Trade Contractor shall keep full and detailed accounts and exercise such controls as may be necessary for proper financial management under this Trade Contract Agreement and as directed and approved by the Authority. Trade Contractor agrees that the Authority can review and audit Trade Contractor's records and shall afford the Authority reasonable access to any records requested to the extent relating to the Trade Contractor's right to payment under and the Trade Contractor's compliance with the terms and conditions of this Trade Contract Agreement. The Trade Contractor shall preserve this information for a period of seven (7) years after final payment, or for such longer period as may be required by Applicable Laws. Subcontractors retained by the Trade Contractor on a "cost-plus" basis shall have the same obligations to retain records and cooperate with audits as are required of the Trade Contractor under this **Paragraph 6.1**.

6.2 Claims and Disputes

6.2.1 Definition. A "**Claim**" is a demand or assertion by a Person seeking as a matter of right, adjustment or interpretation of terms of an agreement, payment of money, extension of time, or other relief with respect to the terms of the Trade Contract Documents. The term "**Claim**" also includes, without limitation, other disputes and matters in question between the Authority and the Trade Contractor, or between the Authority and the Architect arising out of or relating to the

applicable Contract Documents or Trade Contract Documents. Claims must be made by written notice provided by the claimant to the Party against whom the Claim is being made, with a copy to the Authority. The responsibility to substantiate Claims shall rest with the party making the Claim.

6.2.2 Referral to Authority. Claims, including those alleging an error or omission by the Trade Contractor will be referred initially to the Authority for action as provided in **Paragraph 6.3**. The recommendation by the Authority, if any, in response to a Claim shall not be a condition precedent to arbitration or litigation.

6.2.3 Time Limits on Claims. Except as provided in **Subparagraph 6.2.6** below, and except for Claims asserted by the Authority, Claims by any Person that are discovered during the performance of the Trade Contractor Work must be made within twenty-one (21) Days after occurrence of the event giving rise to such Claim or within twenty-one (21) Days after the claimant first recognizes the condition giving rise to the Claim, whichever is later, or said Claim shall be deemed waived. In addition to the foregoing, as soon as the claimant recognizes the conditions giving rise to the Claim, claimant shall provide notice of such conditions to the Authority, and shall use its best efforts to cooperate with the Authority and the Party against whom the Claim is made in any effort to mitigate the alleged or potential damages, delay, or other adverse consequences arising out of the condition which is the cause of such a Claim. Claims may also be reserved in writing within the time limits set forth in this **Subparagraph 6.2.3**. If a Claim is reserved, the Resolution of Claims and Disputes procedures described in **Paragraph 6.3** and **Paragraph 6.4** hereof shall not commence until a written notice from the claimant is received by the Authority.

6.2.4 Continuing Contract Performance. Pending final resolution of a Claim, unless otherwise agreed in writing, the Trade Contractor shall proceed diligently with performance of its Trade Contractor Work, and the Authority shall continue to make payments in accordance with the Trade Contract Documents. In the event the Trade Contractor fails to diligently proceed with its Trade Contractor Work during a period of dispute resolution, the Authority may procure necessary replacement services or work and back-charge all associated costs to the non-performing party.

6.2.5 [RESERVED].

6.2.6 Claims for Concealed or Differing Site Conditions. Notwithstanding anything to the contrary in the Trade Contract Documents, the Trade Contractor acknowledges and agrees that it has thoroughly investigated the existing design and construction of the Project and the future anticipated construction of the Project, and hereby waives any Claims for conditions encountered at the Project Site which are (a) subsurface or otherwise concealed physical conditions which differ materially from those indicated in the Trade Contract Documents, the design of the Project prepared by the Architect, or existing construction and (b) unknown physical conditions of an unusual nature, which differ materially from those ordinarily found to exist and generally recognized as inherent in construction activities of the character provided for in the Trade Contract Documents or the design of the Project prepared by the Architect. The Trade Contractor

acknowledges and agrees that this exclusion of Claims for differing site conditions has been specifically negotiated and that the Trade Contract Amount in **Exhibit 2** contains an adequate and fair contingency to address this specific risk among others.

6.2.7 Claims for Cost. If the Trade Contractor wishes to make a Claim for an increase in the Trade Contract Amount, written notice to the Authority as strictly set forth under this **Paragraph 6.2** is required and shall be given before the Trade Contractor proceeds to execute the Trade Contractor Work or the Trade Contractor's Claim shall be deemed waived. Any Trade Contractor Work completed by the Trade Contractor without the proper notice to and approval by the Authority will not be considered or approved as a change to the Trade Contract Amount.

6.2.8 Claims for Additional Time. If the Trade Contractor wishes to make a Claim for an increase in the Contract Time, written notice shall be given within the time period specified in **Subparagraph 6.2.3** or said Claim shall be deemed waived. The Trade Contractor's Claim shall include an estimate of cost and of probable effect of delay on progress of the Trade Contractor Work and the Construction Schedule. In the case of a continuing delay only one Claim is necessary.

6.2.9 Claims for Consequential Damages. Except as provided in **Exhibit 4**, the Trade Contractor and the Authority waive Claims against each other for consequential damages arising out of or relating to the Trade Contractor Work. This mutual waiver includes:

- .1 damages incurred by the Authority for rental expenses, for losses of use, income, profit, financing, business and reputation, and for loss of management or employee productivity or of the services of such Persons; and
- .2 damages incurred by the Trade Contractor for labor, material, or principal office costs or expenses including the compensation of personnel stationed there, for losses of financing, business and reputation, and for loss of profit except anticipated profit arising directly from the Trade Contractor Work.

This mutual waiver is applicable, without limitation, to all consequential damages due to either party's termination in accordance with **Article 16** below. Nothing contained in this **Subparagraph 6.2.9** shall be deemed to preclude an award of liquidated damages, when applicable, in accordance with the requirements of **Exhibit 4**. In addition, this **Subparagraph 6.2.9** does not apply to or preclude the Authority's right to recover consequential damages to the extent provided below. Notwithstanding anything to the contrary, the Authority does not waive and specifically reserves all rights and claims to recover any and direct damages, indirect damages, incidental damages, consequential, damages incurred by the Authority and Indemnitees, including rental expenses, for losses of use, income, profit, financing, business and reputation, and for loss of management or employee productivity or the services of such Persons, and any other type or form of damages ("**Reserved Damages**") against the Trade Contractor to the extent that such claims

for Reserved Damages are due to the need to repair the Trade Contractor's improper or defective Trade Contractor Work after Substantial Completion or are covered by any insurance available under the OCIP program or under the Trade Contractor's insurance program.

6.3 Review of Claims and Disputes

6.3.1 The Authority, will review all Claims once submitted by the Trade Contractor and take one or more of the following preliminary actions within ten (10) Days of receipt of a Claim: (a) request additional supporting data from the claimant, (b) submit a schedule to the parties indicating when the Authority expects to take action, (c) reject the Claim in whole or in part, stating reasons for rejection, (d) recommend approval of the Claim, (e) suggest a compromise, or (f) not take any of the above actions, in which case the Claim shall be deemed denied. The Authority may also, but is not obligated to, notify the Trade Contractor's surety, if any, of the nature and amount of the Claim.

6.3.2 If a Claim submitted to the Authority has been resolved, the Authority will prepare or obtain appropriate documentation to memorialize and process the resolution.

6.3.3 If a Claim submitted to the Authority has not been resolved after consideration of the foregoing the Authority will, in a timely fashion, notify the parties in writing that the Authority's recommendation will be made within seven (7) Days. Upon expiration of such time period, the Authority will render to the parties its final recommendation relative to the Claim including any change in the Trade Contract Amount or Contract Time or both. The parties may then (a) agree to resolve the Claim or (b) proceed pursuant to **Paragraph 6.4** hereof. If the Authority's recommendation is not submitted within thirty (30) Days of the Authority's receipt of the Claim, the Claim shall be deemed denied.

6.4 Dispute Resolution

6.4.1 Mediation. Claims, disputes, or other matters in controversy arising out of or related to the Trade Contractor Work shall be subject to mediation in Minneapolis, Minnesota as a condition precedent to binding dispute resolution. The mediator's costs shall be shared equally by the Parties in the dispute. The request to mediate may be made concurrently with the filing of binding dispute resolution proceedings but, in such event, mediation shall proceed in advance of binding dispute resolution proceedings, which shall be stayed pending mediation for a period of sixty (60) Days from the date of filing, unless stayed for a longer period by agreement of the Parties or court Order. If an arbitration is stayed pursuant to this **Subparagraph 6.4.1**, the Parties may nonetheless proceed to the selection of the arbitrator(s) and agree upon a schedule for later proceedings.

6.4.2 Claims Subject to Arbitration. Any Claim subject to, but not resolved by, mediation shall be subject to arbitration, which shall be administered by the American Arbitration Association in accordance with its Construction Industry Arbitration Rules ("AAA Rules") in effect as of the Effective Date of this Trade Contract Agreement. The Party filing a notice of demand for arbitration must assert in the demand all Claims then known to that Party on which arbitration is

permitted to be demanded. All proceedings set forth under this **Paragraph 6.4** shall be conducted in Minneapolis, Minnesota.

6.4.3 Notice for Arbitration. Notice of Demand for Arbitration shall be filed, in writing, with the other Party to the applicable agreement, with any Party to be joined pursuant to **Subparagraph 6.4.6** hereof, and with the American Arbitration Association, the Authority, Trade Contractor, and the Architect, to the extent they are not otherwise a Party to the arbitration. At the Authority's election, and its sole discretion, it may invoke application of Fast Track Procedures under the AAA Rules for any such arbitration proceedings initiated under the Contract Documents. The Trade Contractor acknowledges and agrees that Minn. Stat. § 544.42 does not apply to this Project.

6.4.4 Contract Performance During Arbitration. During arbitration proceedings, the Authority, Trade Contractor, Architect, and any Subcontractor or Subconsultant shall comply with **Subparagraph 6.2.4** hereof.

6.4.5 [RESERVED]

6.4.6 Consolidation or Joinder. Any arbitration shall include, by consolidation or joinder, the Architect, Subcontractors, Suppliers, Subconsultants, Trade Contractors, and other Persons bound to arbitrate according to this **Paragraph 6.4** if substantially involved in a common question of fact or law. Any contract between the Trade Contractor and any Subcontractor and Supplier and contracts between Subcontractors and Suppliers and lower tiers of Sub-Subcontractors and suppliers shall include provisions for arbitration, consolidation, and joinder consistent with this **Paragraph 6.4**. The foregoing agreement to arbitrate and consolidation and joinder shall be specifically enforceable under Applicable Laws in any court having jurisdiction thereof.

6.4.7 Judgment on Final Award. The award rendered by the arbitrator or arbitrators shall be final, and judgment may be entered upon it in accordance with Applicable Laws in any court having jurisdiction thereof.

6.4.8 Litigation of Third-Party Claims. If a third-party who is not a member of the Project Team sues a member of the Project Team, or the Authority in a court of law ("**Third-Party Suit**"), then the Authority shall have the absolute discretion to join in the Third-Party Suit members of the Project Team who are involved in common questions of law or fact or whose participation is necessary to provide complete relief in the Third-Party Suit, and the Project Team hereby consents to jurisdiction and venue in any court in which the suit is commenced or to which such Third Party Suit is removed.

6.4.9 Attorneys' Fees and Costs. If any legal action or other proceeding, including arbitration, is brought for the enforcement of the Construction Services Agreement, the Design Services Agreement, this Trade Contract Agreement or the Trade Contract Documents and/or because of an alleged dispute, breach, default or misrepresentation in connection with any provision of those agreements, the prevailing Party shall be entitled to recover all reasonable attorneys' fees, costs, and disbursements that it incurs in any legal action or proceeding.

7. Changes

7.1 Contract Request. All changes to the Trade Contractor Work must be approved in strict accordance with the requirements of this Trade Contract Agreement. The Contract Request Form, and all required contractual documentation associated therewith and required by the Authority, must be provided to and approved by the Authority in writing before commencement of any proposed changes in any part of the Trade Contractor Work. The Authority will administer a Pending Change Report to identify and track any and all potential changes in the Trade Contractor Work, and the Trade Contractor is obligated to provide all supporting documentation reasonably required by the Authority to administer the Pending Change Report. The Trade Contractor is responsible to immediately provide the Authority with timely notification of any pending change associated with the Trade Contractor Work in accordance with the requirements of this **Paragraph 7.1** and the Trade Contract Documents and to provide projected cost impacts, if any, within five (5) Days of notification of such change. The Trade Contractor is responsible to provide final costs associated with any pending change within two (2) weeks of inclusion on the Pending Change Report, or such other timeframe as reasonably agreed to in writing by the Authority. If the Trade Contractor performs any alleged change in the Trade Contractor Work in the absence of proper notice required by the Trade Contract Documents, the Trade Contractor then assumes all liability for such Trade Contractor Work, understands and agrees that the Trade Contractor will not be paid for such Trade Contractor Work.

7.2 Contract Revision. A Contract Revision related to the Trade Contractor Work is a written order signed by the Authority and Trade Contractor, and issued after execution of this Trade Contract Agreement, stating their agreement with respect to a Change in the Trade Contractor Work, and which may include an adjustment in the Trade Contract Amount and/or an adjustment to the Construction Schedule or Contract Time. Costs to the Authority resulting from a Change in the Trade Contractor Work shall be determined in writing between the Authority and the Trade Contractor before issuance of any Contract Revision. The Trade Contractor shall not proceed with any Changes in the Trade Contractor Work either without a prior written authorization from the Authority, or if the Authority does not consider the Trade Contractor Work in question to be a Change in the Trade Contractor Work, then without a written notice of Claim as provided herein. The Trade Contractor agrees that it will not be paid for and waives any Claim for payment associated with any alleged Change in the Trade Contractor Work or any Contract Revision unless the Trade Contractor fully complies with the terms of this **Paragraph 7.2** and the notice of Claims provision **Paragraph 6.2**. The Trade Contractor further assumes any and all risks or liabilities associated with the Trade Contractor proceeding with any alleged Change to the Trade Contractor Work or any pending Contract Revision that is not administered, or preserved by a written notice of Claim, in strict accordance with the Trade Contract Documents. Except as otherwise set forth therein, any executed Contract Revision shall constitute a final settlement of all matters relating to or arising out of the change in the Trade Contractor Work which is the subject of the Contract Revision.

7.3 Construction Change Directive. A “**Construction Change Directive**” is a written order prepared by the Authority, directing a change in the Trade Contractor Work. The Authority may by Construction Change Directive, without invalidating the Trade Contract Documents, order changes in the Trade Contractor Work within the general scope of the Trade Contract Documents consisting of additions, deletions, or other revisions, the Trade Contract Amount and Contract Time being adjusted, if appropriate.

8. Subcontractors

8.1 Award of Subcontractors. Any Subcontractor that the Trade Contractor proposes to use to perform a part of the Trade Contractor Work shall be subject to the approval of the Authority, which shall not be unreasonably withheld. Before this Trade Contract Agreement is executed, the Trade Contractor shall furnish the Authority, in writing, with (a) the name, trade and subcontract amount of all Persons and entities proposed as Subcontractors, and (b) the names of all Persons or entities proposed as Suppliers of the material or equipment identified in the Specifications (including those who are to furnish materials or equipment fabricated to a special design) and, where applicable, the name of the installing Subcontractor. The Authority will promptly reply to the Trade Contractor in writing stating whether or not the Authority, after due investigation, has reasonable objection to any such proposed person or entity.

8.2 Subcontract Relations. Each Subcontract shall obligate the Subcontractor, to the extent applicable to the Trade Contractor Work performed by the Subcontractor, to assume toward the Trade Contractor and the Authority all the responsibilities, terms and conditions of the Trade Contract Agreement that the Trade Contractor assumes toward the Authority.

8.3 Contingent Assignment of Subcontracts. Each Subcontract for a portion of the Trade Contractor Work is assignable by the Trade Contractor to the Authority provided that:

.1 assignment is effective only after termination of the Trade Contractor Work or stoppage of Trade Contractor Work by the Authority as provided in the Trade Contract Agreement and only for those Subcontracts which the Authority accepts by notifying the Subcontractor in writing in the Authority's sole discretion; and

.2 assignment is subject to the prior rights of the Trade Contractor's surety, obligated under bonds relating to the Trade Contractor Work.

8.4 [RESERVED].

8.5 Payments to Subcontractors and Suppliers. Before making payments to any of its Suppliers or Subcontractors, Trade Contractor shall obtain lien waivers from all Subcontractors and Suppliers providing services, materials or work to Trade Contractor on the Project and representation from said Subcontractors and Suppliers that their work is free and clear of liens, Claims, security interests, or encumbrances. The Trade Contractor further expressly undertakes to defend and indemnify the Authority and the Indemnitees, at the Trade Contractor's sole expense with independent counsel of the indemnified party's choice, against any actions, lawsuits, or proceedings brought against the Authority or any Indemnitee as a result of Claims or liens filed against the Trade Contractor, the Trade Contractor Work, the Project Site, any improvements thereon, or any portion of the property of the Authority or any Indemnitee, and the Trade Contractor hereby agrees to pay any judgment or Lien resulting from any such actions, lawsuits or proceedings.

9. Coordination with the Authority

9.1 Project Schedule. The Trade Contractor will be responsible for coordinating, scheduling, and integrating the Trade Contractor Work with the Authority’s normal operations or the work of the trade contractors hired by the Authority.

9.2 [RESERVED].

9.3 Damage. The Trade Contractor shall, at its own expense, promptly remedy damage caused by the Trade Contractor to completed or partially completed construction or to property of the Authority or work of other Trade Contractors or Vendors.

9.4 Claims. Claims and other disputes and matters in question between the Authority and the Trade Contractor or Vendor shall be subject to the provisions of **Paragraphs 6.2 - 6.4.**

10. Compliance with Applicable Law

10.1 Equity Plan. The Trade Contractor shall comply with all Applicable Laws and any special requirements in the Contract Documents regarding equal employment opportunity, Targeted Business, and workforce participation initiatives. The Trade Contractor shall demonstrate good faith efforts to utilize minority (“**MBE**”) and women-owned (“**WBE**”) business enterprises (hereinafter referred to as “**Targeted Businesses**”). The Authority has adopted the Equity Plan applicable to the Trade Contractor and the Trade Contractor agrees that it will follow the Equity Plan attached as **Exhibit 3** hereto and that the Equity Plan is applicable to its Trade Contractor Work.

11. Payments

11.1 Amount Payable. The Trade Contract Amount is the maximum total amount payable to the Trade Contractor for performance of the Trade Contractor Work under the Trade Contract Agreement.

11.2 Schedule of Values. The Trade Contractor shall submit to the Authority a Schedule of Values allocated to various portions of the Trade Contractor Work, prepared in such form and supported by such data to substantiate its accuracy as the Authority deems necessary. The Authority shall have the right to approve the Trade Contractor’s format of the Schedule of Values and all subsequent forms of the Schedule of Values.

11.3 Applications for Payment. The Trade Contractor shall submit to the Authority an itemized Application for Payment for completed portions of the Trade Contractor Work in accordance with the Schedule of Values. Such Application for Payment shall be notarized, if required, and supported by such data and documents substantiating the Trade Contractor’s right to payment as the Authority may require. By signing and submitting an Application for Payment, Trade Contractor shall represent and warrant that Trade Contractor has no Knowledge of and waives any Claims, specifically including Claims for any adjustment to the Contract Time or adjustments to the Trade Contract Amount, based on events or circumstances existing or occurring before the date of the subject Application for Payment, except as specifically stated in said Application for Payment or as may have been properly preserved by timely written notice of a Claim as required by the Trade Contract Documents. Duly executed waivers of liens and Claims for payment from all Subcontractors, Suppliers, and lower tier Subcontractors establishing payment or satisfaction of all amounts requested by the Trade Contractor on behalf of such entities or

persons in the previous Application for Payment must be submitted with the Trade Contractor's current Application for Payment.

11.4 Materials and Equipment. Unless otherwise provided in the Trade Contract Documents, payments shall be made on account of materials and equipment delivered and suitably stored at the Project Site for subsequent incorporation in the Trade Contractor Work. If approved in advance by the Authority, payment may be made for materials and equipment suitably stored off the Project Site at a location agreed upon in writing.

11.5 Title to Trade Contractor Work. The Trade Contractor warrants that title to all Trade Contractor Work covered by an Application for Payment will pass to the Authority no later than the time of payment. The Trade Contractor further warrants that upon submittal of an Application for Payment, all Trade Contractor Work for which Certificates for Payment have been previously issued and payments received from the Authority shall be free and clear of liens, Claims, security interests, or encumbrances in favor of the Trade Contractor, Subcontractors, Suppliers, Sub-Subcontractors, or other Persons able to make a Claim by reason of having provided labor, materials, and equipment relating to the Trade Contractor Work, except as specifically stated in said Application or as may have been properly preserved by timely written notice of a Claim as required by the Trade Contract Documents.

11.6 Approval of Applications for Payment. Based upon Applications for Payment submitted by the Trade Contractor and as approved by the Authority, the Authority shall make payment to the Trade Contractor. The period covered by each Application for Payment shall be one (1) calendar month ending on the last day of the month, or as otherwise agreed to between the Authority and Trade Contractor in writing. Provided that a Trade Contractor Application for Payment is approved for full or partial payment, the Authority shall make payment of the approved amount to the Trade Contractor not later than forty-five (45) Days after the Authority has approved Application for Payment.

11.6.1 The Authority shall pay interest of one and one-half percent (1.5%) per month (or any part of a month) to the Trade Contractor on an undisputed amount not paid to the Trade Contractor. The minimum monthly interest penalty payment for an unpaid balance of \$100 or more is \$10. For an unpaid balance of less than \$100, the Authority shall pay the actual interest penalty due to the Trade Contractor in accordance with Minnesota Statutes.

11.7 Decisions to Withhold Certification. The Authority may withhold a Certificate for Payment in whole or in part, to the extent reasonably necessary to protect the Authority, if in the Authority's withholding is justified because of: (1) defective Trade Contractor Work not remedied; (2) third-party claims filed or reasonable evidence indicating probable filing of such claims; (3) failure of the Trade Contractor to properly pay Subcontractors or Suppliers; (4) reasonable evidence that the Trade Contractor Work cannot be completed for the unpaid balance of the Trade Contract Amount or by the required Contract Time; (5) loss or damage incurred by the Authority or another party; or (6) persistent failures to carry out the Trade Contractor Work in accordance with the Trade Contract Documents. The Authority shall not be deemed to be in breach of the Trade Contract Documents by reason of the withholding of any payment pursuant to any provision of the Trade Contract Documents.

11.8 [RESERVED]

11.9 Payments to Subcontractors. If the Authority makes payment directly to the Trade Contractor for Trade Contractor Work performed by Subcontractors, then the Trade Contractor shall promptly pay each Subcontractor, in accordance with the approved Application for Payment submitted by the Trade Contractor, on account of such Subcontractor's portion of the Trade Contractor Work, the amount to which said Subcontractor is entitled. The Authority shall have no obligation to pay or to see to the payment of money to a Subcontractor or Supplier. The Trade Contractor must pay interest of one and one-half percent (1.5%) per month (or any part of a month) to the Subcontractor on any undisputed amount not paid on time to the Subcontractor. The minimum monthly interest penalty payment for an unpaid balance of \$100 or more is \$10. For an unpaid balance of less than \$100, the Trade Contractor shall pay the actual penalty due to the Subcontractor in accordance with Minnesota Statutes. The Trade Contractor shall, by appropriate agreement with the Trade Contractor and each Subcontractor, require each Subcontractor to make payments to Sub-Subcontractors in similar manner upon receipt of payment from the Trade Contractor.

11.10 [RESERVED]

11.11 Effect of Payment. An approved Application for Payment, Certificate for Payment, a progress payment or partial payment of any kind, or partial or entire use or occupancy of the Project by the Authority shall not constitute, nor shall it be construed as, acceptance or approval of any portion of the Trade Contractor Work not in accordance with the Trade Contract Documents or to otherwise relieve the Trade Contractor of any of its obligations hereunder with respect thereto.

11.12 to 11.14 [RESERVED].

11.15 Certifications. The Trade Contractor is required to certify that all amounts owed and requested under the Application for Payment are due to the Trade Contractor, are accurate and correct, and that all of the Trade Contractor Work completed to the date of the Application for Payment has been completed in accordance with the Trade Contract Agreement.

11.16 Subcontractor Work. Notwithstanding the provisions of **Paragraph 11.15** and notwithstanding the wording of such certificates, the Trade Contractor shall ensure that each Subcontractor's work is satisfactory and in good order pursuant to the Trade Contract Documents pending the issuance of a final Certificate of Payment and the Trade Contractor shall be responsible for ensuring that the correction of defects or Trade Contractor Work not performed regardless of whether or not such defects were apparent when such certificates were issued.

12. Final Completion and Final Payment

12.1 Final Completion. Upon receipt of written notice that the Trade Contractor Work is ready for final inspection and acceptance and upon receipt of a final Application for Payment, the Authority will promptly make such inspection and, when the Authority determines that the Trade Contractor Work is acceptable under the Trade Contract Documents, the Trade Contractor Work has been fully performed and the Trade Contractor has achieved Final Completion, the Authority will issue the final Certificate for Payment stating the entire balance found to be due the Trade Contractor and noted in said final

Application for Payment is due and payable. The final Certificate for Payment will not be issued until all warranties have been received and accepted by the Authority.

12.2 Final Payment. Final Payment shall be made by the Authority to the Trade Contractor when (a) the Trade Contractor has achieved Final Completion, except for the Trade Contractor's responsibility to correct defective or nonconforming Work and to satisfy other requirements, if any, which necessarily survive Final Payment; (b) a final Application for Payment has been submitted by the Trade Contractor and reviewed by the Authority's accountants; and (c) a final Application for Payment has then been approved in writing by the Authority. The Authority shall make such Final Payment, including any remaining retainage, if all of the Trade Contractor's responsibilities have been satisfied (otherwise any remaining retainage shall be released upon satisfaction of all requirements) not more than ninety (90) Days after approval by the Authority of the final Application for Payment, or as required by Applicable Law. No Final Payment shall be issued until all final Contract Revisions have been issued and executed with each final Change Order and Trade Contractor has provided the Authority with a detailed list of all Claims that are still unresolved at the time Final Payment is requested.

13. Safety

13.1 Safety Programs. The Trade Contractor shall control and be responsible for establishing and enforcing its safety programs. The Trade Contractor will also take reasonable precautions for the protection of the Trade Contractor Work, third-party materials and equipment stored on the Project Site in accordance with the Trade Contractor's direction, and other property at or on Adjacent Property to the Project Site.

13.2 [RESERVED].

13.3 Emergencies. The Trade Contractor shall promptly report in writing to the Authority and Architect all accidents arising out of or in connection with the Trade Contractor Work which cause death, personal injury, or property damage, giving full details and statements of any witnesses. In addition, if death, serious personal injuries, or serious property damages are caused, the accident shall be reported immediately by telephone or messenger to the Authority and the Architect.

14. Trade Contractor's Insurance for Purposes of Trade Contractor's Work.

14.1 Required Insurance. Before beginning its Trade Contractor Work, the Trade Contractor shall obtain and maintain the Required Insurance as set forth in **Appendix B**, and fully comply with all provisions thereof unless additional insurance is required by a Contract Revision and/or the insurance referenced is provided through a controlled insurance program. In addition, Trade Contractor shall obtain and maintain, in a company or companies lawfully authorized to do business in the State of Minnesota, such insurance as will protect the Trade Contractor and the Authority from claims set forth below which may arise out of or result from the Trade Contractor's operations and Trade Contractor Work under this Trade Contract Agreement and for which the Trade Contractor may be legally liable, whether such operations be by the Trade Contractor or by a Subcontractor, Sub-Subcontractor or by anyone directly or indirectly employed by any of them, or by anyone for whose acts any of them may be liable:

- .1 claims under workers' compensation, disability benefit and other similar employee benefit acts which are applicable to the Trade Contractor's Work;
- .2 claims for damages because of bodily injury, occupational sickness, disease or death of the Trade Contractor's employees;
- .3 claims for damages because of bodily injury, sickness or disease, or death of any Person other than the Trade Contractor's employees;
- .4 claims for damages insured by usual personal injury liability coverage which are sustained (a) by a Person as a result of an offense directly or indirectly related to employment of such Person by the Trade Contractor, or (b) by another Person;
- .5 claims for damages, other than to the Trade Contractor Work itself, because of injury to or destruction of tangible and intangible property, including loss of use resulting therefrom whether or not the tangible or intangible property is physically injured or destroyed;
- .6 claims for damages because of bodily injury, death of a person or property damage arising out of ownership, maintenance or use of a motor vehicle or equipment;
- .7 to the fullest extent permitted by law, claims involving contractual liability insurance applicable to the Trade Contractor's obligations under **Paragraph 4.18** hereof, subject to industry standard policy terms and conditions;
- .8 claims for professional liability (errors & omissions) for Trade Contractor's professional design services performed as part of the Trade Contractor Work; and
- .9 claims for damages because of loss of capital equipment and tools that are owned or rented by the Trade Contractor or its Subcontractors.

14.1.2 The costs of all insurance premiums required under this **Paragraph 14.1** and **Appendix B**, shall be included in the calculation of the Trade Contract Amount as set forth in **Exhibit 2** of the Agreement. The costs of all associated deductibles required under this **Paragraph 14.1** and **Appendix B**, shall be included in the Trade Contract Amount. The Trade Contractor hereby agrees to deliver to the Authority within ten (10) Days of the date of this Trade Contract Agreement and prior to any equipment or personnel being utilized in connection with the Project or the Trade Contractor Work or brought onto the Project Site, certificates of insurance evidencing the required coverages with limits not less than those specified in **Appendix B**. The Authority and the Indemnitees shall be included as additional insureds as set forth in **Appendix B**. The Commercial General Liability Policy, Automobile Policy, and Umbrella/Excess Liability Policy obtained under or pursuant to this **Paragraph 14.1** and **Appendix B**, shall each be primary and non-contributory to any valid and collectible insurance carried separately the Authority, or any of the Indemnitees, except for Builders Risk insurance. Further, the Trade Contractor warrants and represents that it will provide that no less than thirty (30) Days' prior written notice to the Authority and the Indemnitees before any material alteration, cancellation, non-renewal or expiration of the coverage to the insurance it obtains pursuant to this **Paragraph 14.1** and **Appendix B**.

14.1.3 Thirty (30) Days prior to the expiration or non-renewal of any insurance required by this **Paragraph 14.1** and **Appendix B**, the Trade Contractor shall supply the Authority with certificates of insurance and amendatory riders or endorsements that clearly evidence the continuation of all coverage in the same

manner, limits of protection, and scope of coverage as is required in this **Paragraph 14.1**. All renewal and replacement policies shall be in form and substance satisfactory to the Authority and written by carriers acceptable to the Authority.

14.1.4 Any general aggregate limit under the Trade Contractor's Commercial General Liability Policy and Umbrella/Excess Liability Policy shall apply to this Project separately and shall not require exhaustion of any policies providing Trade Contractor coverage as an additional insured.

14.1.5 The Trade Contractor shall cause each first-tier Subcontractor to (a) provide insurance in accordance with the terms and conditions of Trade Contractor's standard Subcontract and reasonably satisfactory to the Authority, and (b) name the Architect, Authority and the Indemnitees as additional insureds under the Subcontractor's Commercial General Liability Policy. The additional insured endorsement included on the Subcontractor's Commercial General Liability Policy shall state that coverage is afforded the additional insured with respect to claims arising out of ongoing and completed operations performed by or on behalf of the Subcontractor.

14.2 Authority's Liability Insurance

14.2.1 The Authority shall be responsible for purchasing and maintaining the Authority's liability insurance in an amount to be determined by the Authority in its sole discretion.

14.2.2 Any deductibles required to be paid for claims made by the Trade Contractor or Subcontractors against the Authority's liability insurance shall be paid by the claiming Trade Contractor or claiming Subcontractor.

14.3 Property Insurance

14.3.1 Before any portion of the Trade Contractor Work is commenced, the Authority shall purchase and maintain property insurance and/or builder's risk insurance in an amount and with coverages to be determined by the Authority for the Trade Contractor Work at the Project Site or portions thereof and materials stored off the Project Site or being shipped to the Project Site.

14.3.2 to 14.3.6 [RESERVED]

14.3.7 The Authority, Architect, and Trade Contractor waive all rights of subrogation and claims of any sort or kind against each other and any of their respective Subconsultants, Subcontractors, Suppliers, Sub-Subcontractors of all tiers, agents, and employees, whether directly or indirectly through any means through their Subconsultants, Subcontractors, Sub-Subcontractors of all tiers, agents, and employees, for loss or damages caused by fire or other named perils to the extent covered by property insurance obtained pursuant to this **Paragraph 14.3** or other property insurance applicable to the Trade Contractor Work, except such rights as they have to proceeds of such insurance held by the Authority as fiduciary. The Trade Contract Documents hereby require of the Authority, Architect, and Trade Contractors, if any, and their Subconsultants, Subcontractors, Sub-

Subcontractors of all tiers, agents, and employees of any of them, by appropriate written agreement, to include similar waivers of subrogation each in favor of other parties enumerated herein. All insurance policies required in the Trade Contract Documents shall provide such waivers of subrogation by endorsement or otherwise. A waiver of subrogation shall be effective as to a Person even though that Person would otherwise have a duty of indemnification, contractual or otherwise, did not pay the insurance premium directly or indirectly, and whether or not the Person or entity had an insurable interest in the property damaged.

14.3.8 A loss insured under the Authority's property insurance shall be adjusted by the Authority and made payable to the Authority for the benefit of the insureds, as their interests may appear, subject to requirements of any applicable mortgagee clause. Any costs, including attorneys' fees, involved in adjusting the loss shall be reimbursed to the Authority if not covered by the property insurance. The Trade Contractor shall pay Subcontractors their just shares of insurance proceeds received by the Trade Contractor, and by appropriate agreements, written where legally required for validity, shall require Subcontractors to make payments to their Sub-Subcontractors in similar manner.

14.3.9 to 14.3.10 [RESERVED]

14.3.11 Partial use shall not commence until the insurance company or companies providing property insurance have consented to such partial use by endorsement or otherwise. The Authority and the Trade Contractor shall take reasonable steps to obtain consent of the insurance company or companies and shall, without mutual written consent, take no action with respect to partial occupancy or use that would cause cancellation, lapse of reduction of insurance.

14.3.12 Any deductibles required to be paid for Claims made by the Trade Contractor or Subcontractors against Authority's Property and/or Builder's Risk insurance shall be paid by the claiming Trade Contractor or claiming Subcontractor.

14.4 Bonds

14.4.1 Pursuant to Minnesota Statutes §§ 574.26 - 574.32 and the Act, the Trade Contractor is required to provide a Payment Bond and a Performance Bond each in an amount equal to one-hundred percent (100%) of the Trade Contract Amount and in the form of **Exhibit 5** hereto and from a surety or sureties acceptable to the Authority. If after the giving of the bonds the Trade Contract Amount is increased, for any reason, the Authority may require additional bonds, the amount of which shall be not less than the amount of the increase in the Trade Contract Amount, and if the additional bonds are not furnished within ten (10) Days after demand, the Trade Contractor Work shall cease until the additional bonds are furnished. Bonds shall be executed by a responsible surety and shall remain in effect for a period not less than two (2) years following the date of Substantial Completion or the time required to resolve any items of incomplete Trade Contractor Work and the payment of any disputed amounts, whichever time period is longer. The Performance Bond shall guarantee Trade Contractor will satisfactorily perform each and every part of the Trade Contractor Work, including all guarantees and warranties required

14.4.2 The costs of all bonds required under this **Paragraph 14.4** shall be included in the Trade Contract Amount.

14.4.3 In any Claim involving the surety and the Trade Contractor, the surety shall be bound by and agrees to be a Party to the dispute resolution provisions in **Paragraph 6.2 – 6.4** of this Trade Contract Agreement, including arbitration.

14.5 General Insurance Requirements

14.5.1 If the Authority or any Indemnitee is damaged by the failure of any other party to purchase or maintain insurance required under this **Paragraph 14**, then the party required to obtain or maintain, or to cause to be obtained or maintained, the insurance shall bear all damages and costs, including attorneys' fees and court and settlement expenses, attributable thereto.

14.5.2 If any insurance required herein is to be issued or renewed on a claim-made form as opposed to the occurrence form, the retroactive date for coverage will be no later than the commencement date of the Trade Contractor Work and will state that in the event of cancellation or nonrenewal, the discovery period for insurance claims (tail coverage) will be at least sixty (60) months.

14.5.3 All policies, except for the Professional Liability Policy, and Workers Compensation policies (if such waivers are not available), shall be endorsed to provide a waiver of subrogation in favor of the Authority and Indemnitees.

15. Uncovering and Correction of Trade Contractor Work.

15.1 [RESERVED].

15.2 Correction of Trade Contractor Work

15.2.1 The Trade Contractor shall, at its own expense, promptly correct Trade Contractor Work rejected by the Authority for failing to conform to the requirements of the Trade Contract Documents, whether observed before or after Substantial Completion and whether or not fabricated, installed or completed. The Trade Contractor shall bear all costs of correcting such rejected Trade Contractor Work, including additional Testing and inspections and compensation for the Authority's or a Consultant's services and expenses made necessary thereby.

15.2.2 Within one (1) year after the date of Substantial Completion of the Trade Contractor Work or designated portion thereof, or after the date for commencement of warranties, or by terms of an applicable special warranty required by the Trade Contract Agreement, if any of the Trade Contractor Work is found to be not in accordance with the requirements of the Trade Contract Agreement, the Trade Contractor shall correct it promptly after receipt of written notice from the Authority to do so unless the Authority has previously given the Trade Contractor a written acceptance of such condition. This period of one (1) year shall be extended with respect to portions of Trade Contractor Work first performed after Final Completion by the period of time between Final Completion and the actual performance of the Trade Contractor Work. This obligation under this **Subparagraph 15.2.2** shall survive Final Completion and acceptance of the Trade Contractor Work under the Agreement and termination of the Agreement.

15.2.3 If the Trade Contractor fails to correct nonconforming Trade Contractor Work within a reasonable time, the Authority may correct it.

15.2.4 The Trade Contractor shall be responsible for all reasonable and direct costs of the Authority resulting from corrections in the Trade Contractor Work for which Trade Contractor is responsible and shall be further responsible for any Design Services which are caused or necessitated by errors, omissions, inconsistencies or other damages caused by the Trade Contractor and for which the Trade Contractor is responsible.

15.2.5 Nothing contained in this **Paragraph 15.2** shall be construed to establish a period of limitation with respect to other obligations that the Trade Contractor might have under the Trade Contract Agreement. Establishment of the time period of one (1) year as described in **Subparagraph 15.2.2** relates only to the specific obligation of the Trade Contractor to correct Trade Contractor Work, and has no relationship to the time within which the obligation of the Trade Contractor to comply with the Trade Contract Agreement may be sought to be enforced, nor to the time within which proceedings may be commenced to establish the Trade Contractor's liability with respect to the Trade Contractor's obligations other than specifically to correct its Trade Contractor Work.

16. Termination or Suspension by Authority

16.1 Termination or Completion of the Trade Contractor Work by the Authority for Cause. If the Trade Contractor defaults or neglects to carry out the Trade Contractor Work in accordance with this Trade Contract Agreement and fails, in the reasonable determination of the Authority, within a seven (7) Day period after receipt of written notice from the Authority to commence and continue correction of such default or neglect with diligence and promptness, the Authority may, without prejudice to other remedies the Authority may have, terminate this Trade Contract Agreement and commence and continue to carry out the Trade Contractor Work or terminate the Trade Contractor Work.

16.2 Suspension or Termination by the Authority for Convenience. The Authority may, in its sole discretion and at any time, suspend or terminate this Trade Contract Agreement for the Authority's convenience and without cause.

16.2.1 Upon receipt of written notice from the Authority of such suspension or termination for the Authority's convenience, the Trade Contractor shall:

- .1** cease operations as directed by the Authority in the notice;
- .2** take actions necessary, or that the Authority may direct, for the protection and preservation of the Trade Contractor Work; and
- .3** except for Trade Contractor Work directed to be performed prior to the effective date of suspension or termination stated in the notice, suspend or terminate all existing Subcontracts and purchase orders and enter into no further Subcontracts and purchase orders.

16.2.2 In case of such termination for the Authority's convenience, the Trade Contractor shall recover, as its sole remedy, payment for the Trade Contractor Work properly performed prior to the effective date of termination and for

equipment ordered and not returnable, and proven costs of termination for the Trade Contractor such as, for example, restocking charges, non-cancelable material purchase orders, and attributable to the Trade Contractor Work actually executed. The Trade Contractor hereby waives and releases all other Claims for payment and damages, including anticipated fees, profits or lost overhead for portions of the unperformed Trade Contractor Work. The Authority shall be credited for:

- .1 payments previously made to the Trade Contractor for the terminated portion of the Trade Contractor Work;
- .2 Claims that the Authority has against the Trade Contractor under this Trade Contract Agreement; and
- .3 the value of the materials, supplies, equipment, or other items that are to be disposed of by the Trade Contractor that are part of the Trade Contract Amount.

17. General Provisions

17.1 Nondiscrimination. In connection with the performance of its Trade Contractor Work, the Trade Contractor agrees not to illegally discriminate against any employee or applicant for employment for any reason, including: age, race, sex, national origin, ancestry, religion, or color.

17.2 Successors and Assigns. The Authority and Trade Contractor each bind themselves, their partners, successors, permitted assigns, and legal representatives to the other Party to this Trade Contract Agreement and to the partners, successors, permitted assigns, and legal representative of such other Party with respect to covenants of this Trade Contract Agreement. Notwithstanding anything to the contrary in this Trade Contract Agreement, it is acknowledged and agreed that the Authority shall have the right to assign all its rights and duties under this Trade Contract Agreement without the consent of Trade Contractor to third parties. This Trade Contract Agreement may not be assigned by Trade Contractor without the prior written approval of the Authority, which approval may be withheld in the Authority's sole discretion.

17.3 Inspection. Inspection of the progress, quantity, or quality of the Trade Contractor Work done by the Authority, any Authority representative, any Governmental Agency, the Architect, or any inspector, shall not relieve the Trade Contractor of any responsibility for the compliance of the Trade Contractor Work with the Trade Contract Documents. No supervision or inspection by the Authority's representative, nor right of the Authority to act, nor any other actions taken by the Authority's representative shall relieve the Trade Contractor of any of its obligations under the Trade Contract Documents nor give rise to any duty on the part of the Authority. If any of the Trade Contractor Work is required to be inspected or approved by any Governmental Authority, the Trade Contractor shall cause such inspection or approval to be performed. No inspection performed or failed to be performed by the Authority hereunder shall be a waiver of any of the Trade Contractor's obligations hereunder or be construed as an approval or acceptance of the Trade Contractor Work or any part thereof.

17.4 -.5 [RESERVED].

17.6 Governing Law, Venue, and Jurisdiction. The laws of the State of Minnesota, without giving any effect to conflicts of law provisions, shall govern and construe this Trade Contract Agreement. Each Party to this Trade Contract Agreement agrees that except for those Claims or disputes which are subject to dispute resolution requirements set forth in **Paragraphs 6.2 to 6.4** of this Trade Contract Agreement, any suit, action, or other legal proceeding shall be brought in the courts of the State of Minnesota, Fourth Judicial District, Hennepin County District Court and each Party consents to the jurisdiction of such court in any such suit, action, or proceeding.

17.7 Project Labor Agreement. The Trade Contractor has received, reviewed, and agrees to comply with the Project Labor Agreement for the Project attached hereto as **Exhibit 6** regarding its Trade Contractor Work.

17.8 Warranty.

17.8.1 The Trade Contractor warrants to the Authority that the Trade Contractor Work will be of good quality and new unless otherwise required or permitted by the Trade Contract Documents, that the Trade Contractor Work will be free from defects. The Trade Contractor represents and warrants to the Authority that its design and materials and workmanship, including its construction means, methods, procedures, and techniques necessary to perform the Trade Contractor Work, and its use of materials, selection of equipment, and requirements of product manufacturers are and shall be consistent with: (a) good and sound practices within the construction industry; (b) generally prevailing and accepted industry standards applicable to the Trade Contractor Work; (c) requirements of any warranties applicable to the Trade Contractor Work; and (d) all Applicable Laws. Trade Contractor Work not conforming to these requirements, including Substitutions not properly approved and authorized, shall be considered defective, and promptly after notification of non-conformance shall be repaired or replaced by Trade Contractor with Trade Contractor Work conforming to this warranty. The Trade Contractor's warranty excludes remedy for damage or defect caused by normal wear and tear under normal usage. If required by the Authority, the Trade Contractor shall furnish satisfactory evidence as to the kind and quality of materials and equipment.

17.9 Notice Provisions. Every notice, demand, request, consent, approval, or other communication, including notice of breach, indemnity, suspension, termination, or default, that either the Trade Contractor or Authority is required or desires to give or make to the other Party hereto shall, notwithstanding any other provisions of this Trade Contract Agreement, be effective only if given in writing and delivered by hand and receipted for, or by registered or certified mail, postage-prepaid, return receipt requested, or by overnight mail as follows:

17.9.1 [Reserved]

17.9.2 If to the Authority, addressed to:

Minnesota Sports Facilities Authority
1005 4th Street South
Minneapolis, MN 55415
Attention: James Farstad

Executive Director
Fax: 612-332-8334

with a copy to: Dorsey & Whitney, LLP
Suite 1500
50 South Sixth Street
Minneapolis, MN 55402-1498
Attention: Jay R. Lindgren
Fax: 612-340-2868

with a copy to: Fabyanske, Westra, Hart & Thomson, PA
333 South Seventh Street, Suite 2600
Minneapolis, MN 55402
Attention: Dean B. Thomson
Fax: 612-359-7602

17.9.3 If to the Trade Contractor, addressed to:

Or to such other address or addresses or via other means as Authority and Trade Contractor shall from time to time designate by written agreement and notice given and delivered as aforesaid.

17.10 Public Project. The Parties agree and acknowledge that the Project is a public project and the Project will be used for public purposes and all of the Trade Contractor Work hereunder is in furtherance of a public project.

17.11 Prevailing Wages. The Trade Contractor shall pay the prevailing wage rates, prevailing hours of labor, and hourly basic rates of pay determined for this Project, and will incorporate into this Trade Contract Agreement the applicable wage determinations for Trade Contractor Work along with language from the commissioner of the state Department of Labor and Industry that will notify the Trade Contractor and its Subcontractors of the applicability of Minn. Stat. §§ 177.41 to 177.44 to this Project. The Trade Contractor shall comply with prevailing wage requirements under Minn. Stat. §§ 177.41 to 177.43 or as otherwise required by the Trade Contract Documents or Applicable Laws.

17.12 Confidentiality

17.12.1 The Trade Contractor, its employees, Subcontractors, and agents shall keep strictly confidential all Confidential Information concerning and relating to the Trade Contract Agreement and the Project. The Trade Contractor, its officers, agents, owners, partners, employees, volunteers, and Subcontractors shall abide by the provisions of the Minnesota Government Data Practices Act, Minnesota Statutes, ch. 13 (the “MGDPA”) and all other Applicable Laws relating to data privacy or confidentiality, and as any of the same may be amended. The Trade Contractor agrees to defend, indemnify, and hold harmless the Indemnitees from and against any claims resulting from the unlawful disclosure and/or use of such protected data by the Trade Contractor or the officers, agents, owners, partners,

employees, volunteers, assignees, or Subcontractors of the Trade Contractor, or other noncompliance with the requirements of this **Subparagraph 17.12**.

17.12.2 The Trade Contractor's or other Project Team members' confidentiality and non-disclosure obligations shall survive the expiration or earlier termination of their respective agreements and shall continue for a period of seven (7) years following the expiration or earlier termination of their respective agreements.

17.13 Trade Secrets, Trademarks and Trade Names

17.13.1 The Trade Contractor, and Project Team acknowledge that the Authority may provide the Trade Contractor and Project Team with access to certain information which may qualify as a Trade Secret under Applicable Laws, and the Trade Contractor and Project Team agree that for all such Trade Secrets that come into their possession, custody or control: (a) such Trade Secrets shall remain the sole property of the Authority, as applicable; (b) the Trade Contractor and Project Team shall maintain the secrecy of the Trade Secrets for so long as they remain Trade Secrets under Applicable Laws; and (c) immediately upon the expiration or earlier termination of the Project, the Trade Contractor and Project Team shall deliver to the Authority all Trade Secret documentation and any and all copies thereof, regardless of form or content.

17.13.2 The Trade Contractor and Project Team may publish information (other than Trade Secrets and Confidential Information, which shall not be published) and images resulting from or relating to the Trade Contractor Work only after obtaining the Authority's prior written approval.

17.14 Press Releases and Other Promotional Materials

17.14.1 Both prior to, during, and after completion of the Project, the Authority shall control the issuance of all press releases and all contacts with the press and all other media relating to the Project. The Trade Contractor and Project Team may not issue any press release, agree to be interviewed by members of the press, or otherwise interact with and/or disseminate information to the press or any media without the prior written consent of the Authority and Team, which consent may be withheld by the Authority in its sole discretion.

17.14.2 After completion of the Project, the Trade Contractor and Project Team may use images of the Project and explanatory text in the Trade Contractor's and Project Team member's marketing and promotional materials, subject to the Authority's written approval.

17.15 Ownership and Use of Architect's Drawings, Specifications and Other Documents

17.15.1 Documents prepared by the Architect are instruments of service for use solely with respect to this Project. The Authority shall retain all common law, statutory and other reserved rights, including the copyright. The Trade Contractor, Subcontractors, sub-subcontractors, and suppliers are authorized to sue and reproduce the instruments of service solely and exclusively for the execution of the Trade Contract Work. The instruments of service may not be used for other

Projects or for additions to this Project outside the scope of the Trade Contract Work without the specific written consent of the Owner.

17.16 Third-Party Beneficiaries. Nothing contained in this Trade Contract Agreement shall create or is intended to create a contractual relationship with, or a cause of action in favor of, any third-party against the Authority or any of the Indemnitees. Notwithstanding the foregoing, the Parties hereto acknowledge and agree to the third-party beneficiary rights established in **Paragraph 17.18** herein.

17.17 Independent Contractor. The Trade Contractor expressly acknowledges that it is an independent contractor and that it is not the representative or agent of the Authority.

17.18 Third-Party Beneficiaries. It is expressly agreed and understood that all of the Indemnitees are intended third-party beneficiaries of all the representations, warranties and covenants made by the Trade Contractor in the Trade Contract Documents, including without limitation the promises of the Trade Contractor to perform and complete the Trade Contractor Work.

18. Entire Agreement

18.1 This Trade Contract Agreement represents the entire agreement between the Authority and Trade Contractor and supersedes any prior negotiations, representations, promises, or agreements whether written or oral. This Trade Contract Agreement may be amended only by written instrument signed by both Authority and the Trade Contractor.

[THIS SPACE LEFT INTENTIONALLY BLANK]

[SIGNATURE PAGE FOLLOWS]

THIS TRADE CONTRACT AGREEMENT is entered into as of the day and year first written above.

AUTHORITY:

By: Michael Vekich

Title: Its Chair

AUTHORITY:

By: Jim Farstad
Title: Its Executive Director

TRADE CONTRACTOR:

By: _____
Title: _____

**DEFINED TERMS OF BE USED IN THE TERMS OF DESIGN AND CONSTRUCTION
APPENDIX A**

DEFINITIONS

Defined terms as used in the Trade Contract Documents shall have the following meanings:

“Act” shall mean 2012 Minnesota Laws, Chapter 299, as enacted or hereafter amended or supplemented, and including any successor law, providing for, among other things, the construction, financing, operation, and long-term use of a multi-purpose stadium and related infrastructure as a venue for the National Football League and a broad range of other civic, community, athletic, educational, cultural, and commercial activities in the City of Minneapolis, Minnesota.

“Additional Insured Parties” shall have the meaning set forth in **Subparagraph 9.1.15** of the Design Services Agreement.

“Adjacent Property” shall mean all land adjoining and surrounding the Stadium Site on which will be located any public streets, sidewalks, plazas, or bridges and any public or private parking facilities or other accoutrements to be developed by Authority or other parties in connection with the Project.

“Affiliate” or “Affiliated Entity” of a specified Person shall mean any entity, corporation, partnership, limited liability company, sole proprietorship or other Person that directly or indirectly, through one or more intermediaries controls, is controlled by, or is under common control with the Person specified. For purposes of the Trade Contract Agreement, the terms “controls,” “controlled by,” or “under common control” means the possession, direct or indirect, of the power to direct or cause the direction of the management and policies of a Person.

“Alternate” shall mean a proposed possible change in the Trade Contractor Work as described in the Trade Contract Documents.

“Applicable Laws” shall mean any and all laws (including all statutory enactments and common law), constitutions, treaties, statutes, codes, ordinances, charters, resolutions, Orders, rules, regulations, guidelines, standards, Governmental Approvals, authorizations, or other directives or requirements of any Governmental Authority enacted, adopted, promulgated, entered, implemented, ordered or issued and in force or deemed applicable by or under the authority of any Governmental Authority having jurisdiction over a Person (or the property of such Person), including the Act and Environmental Laws, applicable to the State, County, City, Authority, Architect, Trade Contractor, and/or other applicable Persons in connection with the design, development, construction, equipping, commissioning, use, occupancy, possession, operation, maintenance and management of the Project. Notwithstanding the foregoing, Applicable Laws shall expressly include all requirements, regulations and administrative orders of the City, County and State, as same may be modified by variances and waivers issued in accordance with Applicable Laws.

“Application for Payment” shall mean the Trade Contractor’s monthly requisition for payment, if any, which shall be submitted on the form provided by the Authority.

“Architect” for purposes of the U.S. Bank Stadium project shall mean the design professional designated by the Authority, its principals, officers, employees, agents, and the permitted successors and assigns. For the purpose of the Trade Contract Agreement and the Trade Contract Documents, the Trade Contractor shall be deemed the Architect of the design/build Trade Contractor Work to be performed hereunder.

“As-Built Drawings” shall mean CAD generated red-lined Construction Documents showing the Trade Contractor Work as constructed, prepared by the Trade Contractor and indicating actual locations of utilities and all changes and alterations made to the Trade Contractor Work during construction. CAD files will be provided by the Trade Contractor in a format acceptable to the Authority.

“Authority” shall mean the Minnesota Sports Facilities Authority, a public body and political subdivision of the State of Minnesota, and its successors, assigns and designees.

“Business Day” or “Work Day” shall mean Monday, Tuesday, Wednesday, Thursday and Friday, excluding any day that banks are required to close in the State of Minnesota, and excluding Saturday and Sunday.

“Certificate for Payment” shall mean a written certificate executed by the Authority indicating the amount that the Trade Contractor is entitled to be paid in connection with each Trade Contractor Application for Payment.

“Change” shall mean an agreed-upon and materially significant Modification to the size, quality, or complexity of the Trade Contractor Work recognized and allowed by the Trade Contract Agreement that also affects the Trade Contract Amount and Contract Time.

“Change Order” shall mean a written order signed by the Trade Contractor, authorizing a change in a Subcontractor’s scope of Work.

“City” shall mean the City of Minneapolis, Minnesota.

“Claim” shall have the meaning set forth in **Subparagraph 6.2.1** of this Trade Contract Agreement.

“Conceptual Design Documents” shall mean the preliminary project work plan, programming report and pre-design documents, concept sketches and renderings illustrating the scale and relationship to the components of the Trade Contractor Work.

“Confidential Information” shall mean all Trade Secrets and other information (whether or not specifically labeled or identified as confidential), in any form or medium, which is disclosed to or learned by the Trade Contractor and/or the Trade Contractor’s Subconsultants, or any other member of the Project Team in the performance of the Trade Contractor Work required in the Trade Contract Documents, or acquired directly or indirectly such as in the course of discussion or investigations by the Trade Contractor and the Trade Contractor’s Subconsultants relating to the Project, and which relates to the Authority’s business, finances, marketing strategy, products, services, research or development, suppliers, clients, or customers, or which relates to similar information of a third-party who has entrusted such information to the Authority including, without limitation, any specialized know-how, technical or non-technical data, formula, pattern, plan, strategy, compilation, program, device, method, technique, drawing, process, financial or business information, models, novel analysis, work papers, studies or other documents that contain, reflect, or are based on such information.

“Construction Change Directive” shall have the meaning ascribed in **Paragraph 7.3** of the Trade Contract Agreement.

“Construction Documents” shall mean those deliverables to be provided by the Trade Contractor, which are necessary to complete the Trade Contractor’s Work, including, but not limited to, the Drawings and Specifications.

“Construction Documents Phase” shall mean that Phase during which the Construction Documents are being prepared by the Trade Contractor.

“Construction Phase” shall mean that Phase of the Project which shall commence after the Authority provides the Trade Contractor with written Notice to Proceed with the Construction Phase.

“Construction Schedule” shall mean the schedule prepared by a Trade Contractor and approved by the Authority, and all adjustments thereto approved by the Authority, that describes the sequence and timing of the Trade Contractor Work on the Project.

“Consultant” shall mean a Person engaged by the Authority or Trade Contractor to perform a portion of the professional services associated with the Project under direct contract with the Authority or Trade Contractor.

“Consultant’s Services” shall mean the complete professional services to be provided by the Consultant and as described in a Consulting Services Agreement between the Authority, or Trade Contractor and the Consultant, and includes all labor, materials, equipment and services to be provided by the Consultant to fulfill its obligations.

“Consulting Services Agreement” shall mean a contract between the Authority or Trade Contractor and a Consultant for the performance of professional services associated with the Project.

“Contamination” means the presence or release or threat of release of Regulated Substances in, on, under or emanating to or from the Stadium Site, which pursuant to Environmental Laws requires notification or reporting to any Governmental Authority, or which pursuant to Environmental Laws requires the identification, investigation, cleanup, removal, remediation, containment, control, abatement, monitoring of or other Response Action to such Regulated Substances or which otherwise constitutes a violation of Environmental Laws.

“Contract Request Form” shall mean a form on which changes to the Trade Contractor Work or Contract Time are requested or on which approvals to use certain Subcontractors are requested by the Trade Contractor.

“Contract Revision” shall mean a written instrument prepared by the Authority and signed by the Authority and Trade Contractor stating their agreement upon a change in the Trade Contractor’s Work; the amount of the adjustment in the Trade Contract Agreement, if any; the extent of the adjustment in the Contract Time, if any, and the updated Schedule of Values.

“Contract Time” shall be as provided in the Trade Contract Agreement. Adjustments to the Contract Time may include adjustments to the Milestone Dates, the required date of Substantial Completion, or the required date of Final Completion, as applicable and as allowed by the Trade Contract Agreement.

“Coordination Drawings” shall mean drawings prepared by Trade Contractor and its Subcontractors detailing the Trade Contractor Work and the coordination of Trade Contractor Work items among the Trade Contractor and various Subcontractors.

“CPM” shall mean a Critical Path method format to be used for the Construction Schedule.

“Critical Path” shall mean those Trade Contractor Work activities identified on the Construction Schedule which, if delayed, will cause a corresponding Delay in the Substantial Completion Date.

“Day” shall mean a calendar day, unless otherwise specifically designated.

“Delay” shall mean any delay or interruption in the progress of the Trade Contractor Work as anticipated on the approved Construction Schedule.

“Design Development Documents” shall mean the Drawings, Specifications and other documents prepared by the Trade Contractor that establish and describe the size and character of the Trade Contractor Work as to architectural, civil, structural, mechanical and electrical systems, graphics and signage, and other elements, and which include typical construction details, equipment layouts and specifications that identify major materials and systems.

“Design Development Phase” shall mean that Phase during which the Architect prepares the Design Development Documents.

“Design Documents” shall mean, collectively and as applicable, the Conceptual Design Documents, Schematic Design Documents, the Design Development Documents and the Construction Documents prepared by the Trade Contractor.

“Design Phases” shall mean those Phases which are preparatory to the physical construction of the Trade Contractor Work during which the Schematic Design Documents, Design Development Documents and Construction Documents are being prepared by the Architect.

“Design Services” shall mean the complete architectural design and engineering for the Trade Contractor Work, and includes all labor, materials, equipment and services to be provided by the Trade Contractor to fulfill its obligations under the Trade Contract Agreement. The Design Services shall include all of the labor, materials, equipment and services to be provided by the Subconsultants of any tier employed directly or indirectly by the Trade Contractor, and shall include all necessary and appropriate coordination and integration of the Consultant’s Services to allow the Trade Contractor to complete the Trade Contractor Work in accordance with the Design Documents. The Design Services shall be performed in strict accordance with all provisions of the Act.

“Design Services Agreement” shall mean the Agreement between the Architect and the Authority for design of the Project.

“Design Team” shall mean Architect and its Subconsultants as set forth in the Design Services Agreement.

“Drawings” shall mean graphic or pictorial portions of the Design Documents prepared by Trade Contractor, Subconsultants, and Consultants, wherever located and whenever issued, which show, among other things, the design, location and dimensions of the Trade Contractor Work, generally including plans, elevations, sections, details, schedules and diagrams.

“Electronic Data” shall mean Design Documents and other Project, data transmitted in electronic format and as further defined in **Subparagraph 1.3.1** of the Design Services Agreement.

“Environmental Laws” shall mean all Applicable Laws, including any consent decrees, settlement agreements, judgments, or Orders, issued by, or entered into with, a Governmental Authority pertaining or relating to: (a) pollution or pollution control; (b) protection of human health or the environment; (c) the presence, use, management, generation, processing, recycling, transport, storage, collection, disposal or release or threat of release of Regulated Substances; (d) the presence of Contamination; and (e) the protection of endangered or threatened species.

“Final Completion” shall mean that the Trade Contractor has satisfactorily completed all of the Trade Contractor Work in strict conformity with the requirements of the Trade Contract Agreement, the Trade Contractor Work has been finally accepted by the Authority and the Trade Contractor’s submission of and the Authority’s approval of the Trade Contractor’s Final Application for Payment.

“Final Payment” shall mean the last payment to the Trade Contractor, including retainage, in connection with the Trade Contractor Work.

“Force Majeure” shall mean an act of God, fire, tornado, hurricane, named storms, flood, earthquake, explosion, war, terrorism, embargoes, civil disturbance, unusually severe weather that is abnormal and unforeseeable for the time of year in question or industry-wide strikes.

“Governmental Approvals” shall mean all waivers, franchises, variances, permits, authorizations, certificates, registrations, licenses, and Orders of and from any Governmental Authority having jurisdiction over the Project, Trade Contractor Work, Stadium Site, Adjacent Property, Authority, Consultant, Architect, Subconsultant, Subcontractor, Trade Contractor, Vendor City, County, State, and other applicable Persons in connection with the design, development, construction, equipping, commissioning, use, occupancy, possession, operation, maintenance and management of the Project or any Adjacent Property.

“Governmental Authority(ies)” shall mean any federal, state, county, municipal or other governmental department, entity, authority, commission, board, bureau, court, agency, or any instrumentality of any of them having jurisdiction with respect to the Project, Trade Contractor Work, Stadium Site, Adjacent Property, Authority, Consultant, Architect, Subconsultant, Subcontractor, Trade Contractor, Vendor, City, County, State, and other applicable Persons in connection with the design, development, construction, equipping,

commissioning, use, occupancy, possession, operation, maintenance and management of the Project or any Adjacent Property.

“Governmental Body” or **“Governmental Bodies”** shall have the meaning set forth in **Paragraph 12.10** of the Design Services Agreement.

“Guaranteed Completion Date” shall have the meaning set forth in **Exhibit 4** of the Trade Contract Agreement.

“Hazardous Materials” shall mean: (a) any “hazardous waste” as defined by the Resource, Conservation and Recovery Act of 1976 (42 U.S.C. Section 6901, et seq.) as amended, and regulations promulgated thereunder; (b) any “hazardous, toxic or dangerous waste, substance or material” specifically defined as such in (or for the purposes of) the Comprehensive Environmental Response, Compensation and Liability Act of 1980 (42 U.S.C. Section 9601, et seq.), as amended, and regulations promulgated thereunder; (c) any “hazardous waste” or “hazardous substance” as defined by applicable Minnesota State laws and regulations), as amended, and regulations promulgated thereunder; and (d) any hazardous, toxic or dangerous waste, substance, or material as defined in any so-called “superfund” or “superlien” law or any other federal, state or local statute, law ordinance, code, rule, regulation, order or decree regulating, relating to or imposing liability or standards of conduct concerning such waste, substance or material.

“Including” shall encompass the phrase “including without limitation” and be understood to indicate an example and not a limitation.

“Indemnitees” shall mean the Minnesota Sports Facilities Authority, Minnesota Vikings Football, LLC, Minnesota Vikings Football Stadium, LLC, Hammes Company Sports Development, Inc., Architect, Lender(s), their Affiliated Entities and each of the foregoing Persons’ elected officials, appointed officials, board members, directors, officers, shareholders, subsidiaries, parent companies, members, owners, agents, representatives, legal counsel, and employees, together with the constituent partners, members, owners, shareholders, and heirs and estates of each of the foregoing, and the City and State.

“Knowledge” The terms “knowledge,” “recognize” and “discover,” their respective derivatives and similar terms in the Trade Contractor Agreement, as used in reference to the Trade Contractor, shall be interpreted to mean that which the Trade Contractor knows, recognizes, or discovers or should have known, recognized, or discovered utilizing the Standard of Care applicable to the Trade Contractor. The expression “reasonably inferable” and similar terms in the Trade Contract Documents shall be interpreted by the Authority to mean reasonably inferable by the Trade Contractor.

“Legal Requirements” shall mean the requirements set forth in any Applicable Laws.

“Lender” shall mean any bank, insurance company, trust, corporation, association, firm, partnership, Person, or other entity that has loaned or agreed to lend or otherwise provide funds or credit enhancement to enable the development and construction of the Project.

“Master Project Schedule” means the schedule to be prepared by the Authority and the Design Delivery Schedule developed by the Architect and all other activities associated with the Project.

“Milestone Date” shall mean a date in the Construction Schedule identified for its importance in measuring progress of all or part of the Trade Contractor Work.

“Modification” shall mean a writing changing the terms of a contract signed by the Parties to that contract.

“National Football League” or **“NFL”** shall mean, collectively, the Office of the National Football League Commissioner, the National Football League Commissioner, the member clubs of the National Football League, the NFL owners, and/or any other Person appointed by any of the foregoing, or any successor substitute association or entity of which the Team is a member or joint owner and which engages in professional football in a manner comparable to the National Football League.

“NFL Rules and Regulations” shall mean, collectively, the constitution and bylaws, and the rules, guidelines, regulations and requirements of the NFL, and any other rules, guidelines, directive, advisory opinions, regulations or requirements of the Office of the Commissioner of the NFL, and/or any other Person appointed by the foregoing, that are generally applicable to NFL franchises, all as the same now exist or may be amended or adopted in the future.

“Order” mean any judgment, award, decision, directive, consent decree, injunction (whether temporary, preliminary or permanent), ruling, or writ ordered adopted, enacted, implemented, promulgated, issued, entered or deemed applicable by or under the authority of any Governmental Authority or arbitrator that is binding on any Person or its property under Applicable Laws.

“Party” or **“Parties”** shall mean the Authority and/or the Trade Contractor as applicable.

“Pending Change Report” shall mean a summary of the status of all pending requests for Contract Revisions and Change Orders that the Authority may generate from time to time.

“Person” shall mean: (a) an individual, sole proprietorship, corporation, limited liability company, partnership, joint venture, joint stock company, estate, trust, limited liability association, unincorporated association or other entity or organization; (b) any Federal, State, county or municipal government (or any bureau, department, agency or instrumentality thereof); and (c) any fiduciary acting in such

capacity on behalf of any of the foregoing.

“Phase” as used herein, shall mean any one of the various phases, or distinct, contiguous portions of time, of the Trade Contractor Work.

“Project” shall mean the development, design, construction and equipping of the Stadium and the Stadium Infrastructure and any related activities in accordance with the Act.

“Project Labor Agreement” shall mean an agreement by which labor organizations agree to terms and conditions of employment, to cooperate in resolving labor disputes, and to maintain labor peace on the Project.

“Project Manual” shall mean a written volume assembled for the Trade Contractor Work by the Trade Contractor that includes specific instructions to the Project Team setting forth the requirements, policies and procedures for performance and execution of the Trade Contractor’s Design Services and Trade Contractor Work.

“Project Participant” shall mean a member of the Project Team.

“Project Safety Program” shall be developed by Trade Contractor pursuant to the Agreement and Terms of Design and Construction.

“Project Site” shall mean the site where the Project is to be constructed.

“Project Team” shall mean any Person involved in the Project and under a contract with the Authority, including the the Architect and its Subconsultants of any tier, Trade Contractors of all tiers contracted directly by the Authority and Consultants contracted directly by the Authority. The Authority must be presented, and asked to provide written approval of, all agreements or contracts, consistent with the terms and conditions of the Trade Contract Documents, with any member of the Project Team before any services or Trade Contractor Work is to be provided or performed on the Project by any such member.

“Punchlist” shall mean a list, compiled by the Trade Contractor and reviewed by the Architect or Authority at Substantial Completion, and approved by the Authority, which identifies items of Trade Contractor Work that remain to be completed or corrected prior to acceptance of Final Completion.

“Record Drawings” shall mean a reproducible set of Construction Documents into which the Architect has incorporated: (a) clarifications, sketches and other Modifications made by the Architect during the Construction Phase; and (b) significant changes in the Work made during construction as shown on the Trade Contractor’s As-Built Drawings.

“Regulated Substance” shall mean any substance, material or waste, regardless of its form or nature, defined under Environmental Laws as a “hazardous substance,” “hazardous waste,” “toxic substance,” “extremely hazardous substance,” “toxic chemical,” “toxic waste,” “solid waste,” “industrial waste,” “residual waste,” “municipal waste,” “special handling waste,” “mixed waste,” “infectious waste,” “chemotherapeutic waste,” “medical waste,” “regulated substance,” “pollutant” or “contaminant” or any other substance, material or waste, regardless of its form or nature, which otherwise is regulated by Environmental Laws.

“Required Insurance” shall mean the insurance required of the Trade Contractor pursuant to the Trade Contract Agreement and Appendix B.

“Response Action” shall mean the investigation, cleanup, removal, remediation, containment, control, abatement, monitoring of or any other response action to the presence of Regulated Substances or Contamination in, on, at, under or emanating from the Stadium Site, including the correction or abatement of any violation required pursuant to Environmental Laws or by a Governmental Authority.

“Samples” shall mean physical examples that illustrate materials, items of workmanship, and which establish standards by which the Trade Contractor Work will be judged.

“Scheduled Event” shall mean any amateur or professional sporting event (other than a NFL game), exhibition, tournament, musical or theatrical performance and other form of live or broadcasted entertainment, convention meeting, market, or show for which (a) the reasonably expected paid attendance is at least 10,000 Persons and for which tickets or concessions are sold to those attending, or (b) expenses incurred with loss of such Scheduled Event would be at least \$100,000.

“Scheduled Substantial Completion Date” shall have the meaning set forth in **Exhibit 4** of the Trade Contractor Agreement.

“Schedule of Values” shall mean an allocation of the entire Trade Contract Agreement among the various portions of the Trade Contractor Work as reasonably approved by the Authority and to be provided by the Trade Contractor.

“Schematic Design Documents” means drawings prepared by the Trade Contractor that illustrate the scale and relationship of the various Trade Contractor Work components and which also contain square footage and volume calculations for the building interior spaces, building exterior spaces, and major architectural and interior finishes.

“Schematic Design Phase” shall mean that Phase during which the Schematic Design Documents are being prepared by the Trade Contractor.

“Shop Drawings” shall mean drawings, diagrams, illustrations, schedules, performance checks and other data prepared by the Trade Contractor or any Subcontractor to illustrate how a specified portion of the Trade Contractor Work will be constructed.

“Specifications” shall mean the written specifications prepared by the Trade Contractor, Architect, Subconsultants and Consultants consisting of the written requirements for materials, equipment, technical requirements and construction systems, standards and workmanship for the Trade Contractor Work, and performance of related services.

“Stadium” shall mean a multipurpose stadium suitable for NFL football and a broad range of other civic, community, athletic, educational, cultural, and commercial activities.

“Stadium Infrastructure” shall mean plazas, including the Stadium Plaza, parking structures, rights of way, connectors, skyways and tunnels, and other such property, facilities, and improvements, owned by the Authority or determined by the Authority to be reasonably necessary to facilitate the use and development of the Stadium.

“Stadium Plaza” shall mean the open air portion of the Stadium Infrastructure adjacent to the Stadium.

“Stadium Site” shall mean all or portions of the current site of the Existing Stadium and adjacent areas, bounded generally by Park and Eleventh Avenues and Third and Sixth Streets in the City of Minneapolis, together with any vacated streets or other lands acquired for the development, construction and use of the Project.

“Standard of Care” in regard to the professional Design Services provided by the Trade Contractor shall mean that standard of professional care, skill, diligence and quality that prevail among national design firms engaged in the planning, design, and construction administration of large scale and complex systems of similar scope, function, size, quality, complexity and detail, including the design of similar systems for NFL stadiums in comparable urban areas throughout the United States, and further including performance in accordance with Applicable Laws and the NFL Rules and Regulations.

“Standard of Care” in regard to the construction, installation, integration, activation of, and adjustments to, the Trade Contractor Work of the Trade Contractor shall mean that that standard of professional care, skill, diligence and quality that prevail among national firms engaged in the planning, estimating, scheduling, construction, and construction administration of large scale and complex systems of similar scope, function, size, quality, complexity and detail, including the design of similar systems for NFL stadiums in comparable urban areas throughout the United States, and further including performance in accordance with Applicable Laws and the NFL Rules and Regulations.

“Subconsultant” shall mean a Person engaged or to be engaged by the Trade Contractor or Architect to perform a portion of the Design Services. The term “Subconsultant” also includes any lower tier Sub-Subconsultant engaged by a Subconsultant.

“Subcontract” shall mean a contract between the Trade Contractor and a Subcontractor for the performance of a portion of the Trade Contractor Work.

“Subcontract Amount” shall mean the total amount stipulated in a Subcontract to be paid to the Subcontractor for the Subcontractor’s performance of the Subcontract.

“Subcontractor” shall mean a Person engaged by the Trade Contractor to perform a portion of the Trade Contractor Work. The term “Subcontractor” also includes any lower tier Sub-Subcontractor engaged by a Subcontractor.

“Subcontractor Application for Payment” shall mean an application for payment submitted to the Trade Contractor by a Subcontractor.

“Submittal” shall mean a Shop Drawing, Sample, catalog cut or similar item for specific portions of the Work as required by the Construction Documents.

“Substantial Completion” shall have the meaning set forth in Exhibit 4.

“Substantial Completion Certificate” shall mean the certificate issued and approved by the Authority indicating the date upon which the Trade Contractor Work (or a designated portion thereof) is Substantially Complete.

“Substantial Completion Date” or “Date of Substantial Completion” shall mean the date identified in the Substantial Completion Certificate when the Trade Contractor Work (or a designated portion thereof) is Substantially Complete.

“Substitution” shall mean a replacement for or alternative to an item of material or item identified in the Construction Documents which is proposed by the Trade Contractor and approved in writing by Authority.

“Sub-Subcontractor” shall mean a Person engaged by a Subcontractor to perform a portion of the Trade Contractor Work. The term “Sub-Subcontractor” also includes any lower tier Persons engaged by Sub-Subcontractor to perform a portion of the Trade Contractor Work.

“Supplier” shall mean a Person who has an agreement with the Trade Contractor, or any member of the Project Team or any of their Subconsultants, Subcontractors or Sub-subcontractors, of any tier, to supply by sale or lease, directly or indirectly, any materials or equipment for the Trade Contractor Work.

“Suspension” shall mean a delay, re-sequencing, stoppage and/or interruption of the Trade Contractor Work (in whole or in part), in response to a written directive from the Authority.

“Targeted Businesses” shall have the meaning set forth in **Paragraph 10** of the Trade Contract Agreement.

“Termination for Convenience” shall mean the termination of the Trade Contract Agreement or the Trade Contractor Work by the Authority without cause and for the convenience of the Authority as decided in its sole discretion.

“Termination for Default” shall mean the termination of a Party under the Trade Contract Agreement by the Authority for cause.

“Testing” shall mean, performing those tests and inspections of the Trade Contractor Work to determine conformance with the Trade Contract Documents.

“Third-Party Suit” shall mean a summons and complaint served by a third-party who is not a member of the Project Team against a member of the Project Team, the Authority in a court of law.

“Trade Contract” shall mean a contract between the Authority and a Trade Contractor for the performance of a portion of the Project.

“Trade Contract Agreement” shall mean the written agreement between the Authority and the Trade Contractor.

“Trade Contract Amount” shall mean the amount to be paid to the Trade Contractor for the proper performance of the Trade Contract Agreement as set forth more fully in **Exhibit 2**.

“Trade Contract Documents” shall mean all the design and contract documents prepared by Trade Contractor that are necessary to deliver and complete the Trade Contractor Work and provide fully functioning facilities that satisfy the Trade Contractor’s obligations under the Trade Contract Agreement.

“Trade Contractor” shall mean a Person that has a direct contract with the Authority to perform a portion of the Project.

“Trade Contractor Work” shall mean the complete and total construction or performance described in and required by the Trade Contract Documents, including preconstruction and design services and construction services, whether completed or partially completed, and includes all labor, materials, equipment and services required to be provided by the Trade Contractor to fulfill Trade Contractor’s obligations under the Trade Contract Agreement. The Trade Contractor’s Work may constitute the whole or part of the Project. The Trade Contractor’s Work includes all of the labor, materials, equipment and services to be provided by the Subcontractors, Sub-Subcontractors of any tier, material and equipment suppliers employed directly by the Trade Contractor.

“Trademark” shall mean a trademark used by the Authority that is protected under United States or International Trademark Law. Without limiting the foregoing, the term Trademark shall also have the meaning set forth in **Paragraph 1.3** of the Design Services Agreement.

“Trade Secret” shall mean any and all information that comes into the possession, custody or control by, through, from, or on behalf of the Authority without regard to form, including, without limitation, any technical or non-technical data, formula, pattern, compilation, program, device, method, technique, drawing, process, financial data, financial plan, product plan, list of actual or potential customers or suppliers, that is not commonly known by or available to the public and which information: (a) derives economic value, actual or potential, from not being generally known to, and not being readily ascertainable by proper means by, other Persons who can obtain economic value from its disclosure or use; and (b) is the subject of efforts that are reasonable under the circumstances to maintain its secrecy.

“Vendor” shall mean a party supplying FF&E, equipment, material, or other product or service to the Project under a direct contract with the Authority.

“Vendor Contract” shall mean a contract between the Authority and a Vendor for the performance of a portion of the Project.

INSURANCE PROVISIONS OF THE TERMS OF DESIGN AND CONSTRUCTION

APPENDIX B

TRADE CONTRACTOR'S INSURANCE REQUIREMENTS

1. For its design and construction work for the Trade Contractor Work, the Trade Contractor shall, unless otherwise approved in writing by the Authority, obtain and maintain throughout the duration of the Trade Contract Agreement for matters that arise out of or relate to the Trade Contractor Work (or as otherwise specified) insurance of the minimum types and in the minimum amounts described below (“**Required Insurance**”).

1.1 Commercial General Liability Insurance.

1.1.1 Combined single limit of not less than:

\$1,000,000	Each Occurrence
\$2,000,000	General Aggregate
\$1,000,000	Products/Completed Operations Aggregate
\$1,000,000	Personal and Advertising Injury
\$100,000	Fire Legal Liability
\$10,000	Medical Payments

1.1.2 Coverage Required:

- Per project general aggregate,
- Premises-operations,
- Explosion, collapse, underground,
- Products/completed operations,
- Independent contractor,
- Independent Trade Contractor's Liability,
- Blanket contractual liability, subject to industry standard terms and conditions,
- Personal injury liability,
- Employment Practice Liability (which can be provided through a separate policy)
- Electronic data liability property damage,
- General liability primary (non-contributory),
- Additional insured by endorsement (CG 20 10 10/01 and CG 20 37 10 01 or their equivalent) in a form subject to approval by the Authority including waiver of subrogation in favor of the Authority and the Indemnitees but only as arising out of vicarious liability or warranty liability imposed by law because of the acts, errors, or omissions of the Trade Contractor including additional insured coverage for both ongoing and completed operations,
- Supplementary Payments coverage for the benefit of Indemnitees of the Trade Contractor for property damage, bodily injury, and personal and advertising injury,
- Trade Contractor shall secure such endorsements or estoppel certificates from insurer as may be necessary to confirm that the Trade Contract Agreement is an insured contract for purposes of the policy,
- Designated Construction Project(s) General Aggregate Limit endorsement (CG 25 03 03 97 or its equivalent),
- Operations within 50 feet of railroad,
- Defense in addition to limits of liability,
- Broad form Property Damage coverage,
- Definition of Bodily Injury to include Mental Injury and Mental Anguish,
- Mobile Equipment coverage,
- Liability assumed under an insured contract including the tort liability of another assumed in a business contract,
- Libel, slander, false arrest and invasion of privacy,
- Designated Location(s), and

Coverage shall be written on ISO form CG 00 01 12 04 or an equivalent form. Insurance is to be on an occurrence form insuring bodily injury and property damage against the hazards of: construction operations, subcontractor and independent contractor, and shall include an aggregate limit per job site endorsement.

1.2 Business Auto Liability Insurance.

1.2.1 Combined Single Limit of:

\$1,000,000 each Occurrence Bodily Injury and Property Damage

1.2.2 Coverage Required: Primary for all owned automobiles; including liability for all owned, leased, rented, hired/non-owned automobiles; medical payments, uninsured and underinsured motorists coverage. Coverage shall be written on ISO form CA 00 01, CA 00 05, CA 00 12, CA 00 20, or an equivalent form.

The Authority shall be included as additional insured by endorsement in a form subject to approval by the Authority. An MCS-90 endorsement (or its equivalent) shall be attached when operations require this coverage.

1.3 Workers' Compensation Insurance.

1.3.1 Workers' Compensation Limits: Statutory

1.3.2 Employers' Liability Limits:

Bodily Injury by Accident	\$1,000,000	Each Accident
Bodily Injury by Disease	\$1,000,000	Policy Limit
Bodily Injury by Disease	\$1,000,000	Each Employee

1.3.3 Workers Compensation Insurance shall include coverage for Borrowed Servant and Alternate Employer, Voluntary Compensation, unintentional errors or omissions, FELA (in case RR worker/employee injured due to operations of contractor or their agents), The Alternative Employer endorsement shall be attached showing the Authority in the schedule as the Alternate Employer.

1.3.4 Waiver of Subrogation Endorsement in favor of the Authority.

1.4 Excess Liability Insurance with Limits of Not Less Than:

\$10,000,000	Each Occurrence
\$10,000,000	Aggregate
\$10,000,000	Products/Completed Operations Aggregate

Coverage is materially following form of underlying general liability, automobile liability and employers' liability, coverage including, primary, additional insured/non-contributory, and waiver of subrogation. Coverage shall have "drop down" feature and "pay on behalf of" wording. Excess policy shall be primary and any applicable policy by the Authority, Additional Insureds, Indemnitees, or Subcontractors, shall be secondary and non-contributory.

1.5 Builder's Risk. All Risk Form. Builder's Risk coverage at limits determined by the Authority will be provided by the Authority.

If requested, the Trade Contractor shall be provided a copy of the Builder's Risk policy before the Construction Phase of the Trade Contractor Work begins and the Trade Contractor will be named as a loss payee under said policy as its interest may appear at the time of loss.

1.6 Contractor's Professional Liability.

\$1,000,000	Limit of Insurance
\$1,000,000	Annual Aggregate

Coverage shall be maintained uninterrupted for a minimum of twelve years after Substantial Completion. Coverage shall apply to negligent acts, errors or omissions arising from the Trade Contractor's professional services defined to include architecture, engineering, land surveying, landscape architecture, and construction management (or other services if appropriate). The retro date will be prior to the commencement of Trade Contractor Work. This coverage must be primary and non-contributory to any coverage maintained by the Authority or an Indemnitee.

1.7 [RESERVED]

1.8 Property Insurance/Contractor's Equipment

Trade Contractor shall insure its own property and equipment (owned, rented or borrowed) including but not limited to tools, materials, supplies, equipment, forms, scaffolding towers, staging, bunkhouses, and other temporary structures including their contents except for such contents as are to be included in and remain a part of the permanent construction. Trade Contractor shall require its Subcontractors to similarly insure their property and equipment.

2. The Authority does not represent or warrant that coverage and limits of the Required Insurance will be adequate to protect the Trade Contractor, and such coverage and limits shall not be deemed as a limitation on the Trade Contractor's liability under the indemnities provided to the Authority and Indemnitees in the Trade Contract Agreement or any other provision of the Trade Contract Documents.
3. The Trade Contractor represents and warrants that the coverage and limits of the Required Insurance are the coverage and limits currently maintained by the Trade Contractor.
4. Prior to commencing the Trade Contractor Work, the Trade Contractor shall furnish the Authority with a certificate(s) of insurance, executed by a duly authorized representative of each insurer, showing that the Trade Contractor maintains all Required Insurance.
 - 4.1 All certificates shall contain a provision that coverages afforded under the policies will not be cancelled, non-renewed, materially changed, or allowed to expire until at least thirty (30) Days' prior written notice has been given to the Authority. The Trade Contractor shall immediately furnish the Authority copies of all endorsements that are subsequently issued amending coverage or limits.
 - 4.2 The words "endeavor to" and "but failure to mail such notice shall impose no obligation or liability of any kind upon the company, its agents or representatives" shall be deleted from the cancellation or material change of any insurance referred to therein.
 - 4.3 Failure of the Authority to demand such certificate or other evidence of full compliance with the Required Insurance or failure of the Authority to identify a deficiency from evidence that is provided shall not be construed as a waiver of the Trade Contractor's obligation to maintain such insurance.
5. The Authority shall have the right, but not the obligation, to prohibit the Trade Contractor from entering the Project Site until such certificates or other evidence that the Required Insurance has been duly placed in compliance with this Appendix B. The Trade Contractor shall be responsible for any delays arising out of the Trade Contractor's failure to comply with this Appendix B.
6. If the Trade Contractor fails to maintain any or all of the Required Insurance, then, in addition to any other rights or remedies available to the Authority under the Agreement, the Authority shall have the right, but shall not be obligated, to (a) terminate the Trade Contract Agreement, or (b) purchase such insurance for the Trade Contractor in which event the Trade Contractor shall reimburse the Authority or provide for the cost thereof, plus ten percent (10%) as an administrative charge.
7. With respect to the Required Insurance, which the Trade Contractor is obligated to maintain after Substantial Completion, an additional certificate(s) evidencing such coverage shall be promptly provided to the Authority when requested.
8. Trade Contractor shall provide certificates of insurance evidencing the insurance coverage and policy limits required above prior to commencement of the Trade Contractor Work and thereafter shall provide insurance certificates or certified copies of insurance policies as may be specified by the Authority within ten (10) Days of the Authority's written request for said certificates or copies.
9. Trade Contractor will require Subcontractors to provide insurance in accordance with the terms and conditions of its standard Subcontract Agreement. Trade Contractor shall include the above additional insured and waiver of subrogation requirements in all of its Subcontracts, unless otherwise agreed to in writing by the Authority. The Trade Contractor shall be responsible for collecting certificates of insurance and monitoring insurance coverage of its Subcontractors and all lower tier Sub-Subcontractors to verify that the required coverage is maintained as required. All Subcontractors providing professional services shall be required to provide professional liability insurance. In addition, all Subcontractors shall include the same indemnification of the Authority and Indemnitees as provided in the Trade Contract Agreement.
10. Trade Contractor shall secure all Required Insurance from domestic insurer(s) authorized to do business in the State of Minnesota and reasonably satisfactory to the Authority with: (a) a claims paying ability of not less than "AA" (or the equivalent) by Standard & Poors and one other Rating Agency satisfactory to the Authority; and (b) "A:X" or better financial strength rating by AM Best. Trade Contractor shall promptly notify the Authority of any material changes in coverage for all insurance required herein. All coverages except Professional Liability insurance shall be occurrence based. Insurance shall contain such provisions as the Authority deems reasonably necessary or desirable to protect its interest, including endorsement stating that neither the Trade Contractor, the Authority, nor any other party shall be deemed a co-insurer. The Trade Contractor shall pay the premiums for all insurance when due and payable.

EXHIBIT 1
DESCRIPTION OF TRADE CONTRACTOR WORK

The following description is included in the scope of the Trade Contractor Work as Exhibit 1:

The design, work, services, labor, materials, and equipment to be provided by the Trade Contractor and its Subcontractors, Suppliers, Consultants and Subconsultants of any tier and associated with the Trade Contractor Work for the Project are described below, and it is the intention of the Trade Contract Agreement that the Trade Contractor shall provide all design, work, services, labor, materials, and equipment to complete the Trade Contractor Work in accordance with the Trade Contract Agreement, including the Trade Contract Documents and all Applicable Laws.

The Trade Contractor Work shall include the following, without limitation:

1. Design Services.

(a) Trade Contractor shall provide Design Services for the Trade Contractor Work in a manner consistent with the Standard of Care whether performed by the Trade Contractor, its Consultants or any Person engaged directly or indirectly by the Trade Contractor. All staff used by the Contractor in the performance of the Design Services under this Trade Contract Agreement shall be qualified by training and experience to perform their assigned tasks. Trade Contractor's Design Services shall include usual and customary structural, mechanical and electrical engineering services necessary to complete the Trade Contractor Work. Trade Contractor represents that it is: (i) knowledgeable of the Applicable Laws in connection with its scope of Design Services under this Trade Contract Agreement, including all health, safety, fire, environmental, building and zoning codes, rules and regulations, and agrees to comply with each of the foregoing; (ii) experienced and fully qualified to perform the Design Services under this Trade Contract Agreement; and (iii) properly licensed, certified, registered and organized to perform such Design Services under Applicable Laws or any similar requirements.

(b) As part of the consideration contained in the Trade Contract Amount, Trade Contractor and its Consultants and sub-Consultants unconditionally and irrevocably transfer and assign to the Authority all rights, title and interest of any kind or nature in and to their respective Design Documents. Trade Contractor and its Consultants and sub-Consultants acknowledge and agree that for copyright purposes any Design Documents produced or prepared by Trade Contractor and/or its Consultants or sub-Consultants in connection with this Trade Contract Agreement shall be considered works made for hire under Applicable Law, specially ordered or commissioned by the Authority. If, and to the extent that, such Design Documents are deemed not to be works made for hire by a court of competent jurisdiction or an arbitrator, then this Trade Contract Agreement shall constitute an irrevocable assignment and transfer to the Authority of the copyright in all such Design Documents, including the exclusive rights to reproduce, perform and

distribute such Design Documents. The Authority shall have the sole right to bring enforcement actions for infringement of any and all such rights, and the Trade Contractor and its Consultants and sub-Consultants hereby assign any causes of action that may have accrued or will accrue with respect to in such documents, materials, trademarks, service marks and copyrights.

2. Construction Services.

Trade Contractor will provide all labor, materials and equipment necessary to survey, design, engineer, fabricate, ship and install the Trade Contractor Work.

Design

Trade Contractor will provide design services to establish aesthetic and structural specifications for the Trade Contractor Work, including required supporting structure and attachment elements. Scope includes all revision and refinement labor time to reach final acceptance and approval by the Authority and Team.

Project Management

Trade Contractor will provide dedicated project management staff time from project execution to final punch list and acceptance of completed Trade Contractor Work by the Authority and Team. Trade Contractor will coordinate all Trade Contractor Work with the Authority, Team, Construction Manager, Architect, other contractors, and all members of the Project Team.

Site Survey and Scope Review

Before generating any drawings or documents, Trade Contractor will conduct a full site survey to confirm that all existing conditions are adequate to meet the design intent. Trade Contractor will request and coordinate delivery for its review of drawings or other documentation showing or describing the existing conditions, coordinating trades and proposed work proposed to be provided by others. Any specific structural or other modifications to the Stadium structure will be immediately communicated to the Authority and Team for evaluation.

Shop Drawings

Trade Contractor will generate for submittal and approval complete Shop Drawings defining each of the elements of Trade Contractor Work to be fabricated and installed by Trade Contractor. These Drawings will show the location/placement of each component of the Trade Contractor Work and will detail construction methods, "hardening" of components or methods, materials, colors, installation methods, and any applicable coordination information for each element type for its own Trade Contractor Work and with the Work of other adjacent

contractors. Drawings will be based on existing Design Documents, site survey, and any further information received during the design phases, and as coordinated with the Architect, Authority, and Team. Shop Drawings are required for each component type and include: specially-prepared technical data for this Project, drawings, diagrams, schedules, templates, patterns, instructions, measurements, and similar information not in standard print form.

Material/Control Samples

Trade Contractor will submit samples of each material type, and finish and paint color(s), including both fabricated and un-fabricated physical examples of materials, products and units of work. Samples may be both complete units and smaller portions of units of work, either for limited visual inspection or, where indicated, for more detailed testing and analysis.

Engineering Calculations

Engineering calculations will be provided with the Shop Drawings. Engineering calculations will contain information showing that each component and attachment/installation methods will meet the load requirements. Trade Contractor will cause all engineered drawings and documents to be prepared and stamped by a Professional Engineer licensed in Minnesota.

Mock-ups

After approval of Shop Drawings and material samples, and only if requested by the Authority and Team, Trade Contractor will construct mock-ups to verify constructability of fabricated components and illustrate final product for review by the Authority and Team. Mock-ups will be constructed in the same manner as the final product using the same materials and processes to ensure that the requirements of the project are being met before Trade Contractor commences production.

Shop Testing

Fabricated components will be shop tested prior to shipment or delivery to the Project Site.

Material Procurement

The Trade Contractor will order and procure materials as required to maintain the Project schedule. If alternate materials are requested by the Authority or Team, Trade Contractor will advise of any alleged time impacts.

Shipping

All fabricated components will be crated for shipment to the Project Site or off-site storage in a coordinated sequence to facilitate the installation process. All components will be crated in a manner to prevent any damage during transit or storage.

Installation

Trade Contractor will provide onsite installation supervision as required for the unpacking and installation phase of the Trade Contractor Work. Trade Contractor will protect its Work from public access during construction. Trade Contractor will either provide its own safe storage of materials and equipment, toilet facilities, dumpsters/waste removal, and portable cranes, or arrange for the use of the same from the Construction Manager.

Project Closeout

Trade Contractor will prepare and submit all closeout components, including, but not limited to, assembly manuals, maintenance manuals, and closeout package, in printed and PDF format. Documents shall include approved shop drawings annotated with revisions that reflect any changes in the field. Product data are to be provided to the Authority and Team in the form of an Operations and Maintenance Manual. Product data shall include standard printed information on materials, products and systems, including material safety data sheets (MSDS), and not specially prepared for the Trade Contractor Work.

Scope Components and Descriptions: See the products listed below.

LOCATION AND QUANTITIES

ITEM	Make	Model	ELECTRICAL SPECS	143 1st & Fry	101 Minneapolis Cocktail	105 Rusty Taco	113 Rusty Taco	114A Pizza	122 Rusty Taco	129 1st & Fry	134 Pizza	NOTES
Fry Dump Station	Hatco	GRFHS-26	120v/20amp (nema 5-15p)	1								
Counter Top Cooler	TRUE	GDM-09-SQ-HC-LD	115v/60hz/1phase/1.9amp (each)		3							Currently have circuits and may not require additional
Steam Well (table top)	Vollrath		120v/1phase/60hz/5.8amp (each)			3	3		3			
Double Fryer	Vulcan	2ER5OAF	480v/50/60hz/3 phase/50amp	1								Removal of flat top grill and will be replaced by double fryer
Heated Cabinet	Cres Core	H-137-SUA-12D	120v/60hz/1 phase/12amps	1				1				May or may not need an additional circuit for each of these.
Iminger Oven	Lincoln	1132-000-U-K1837	208v/60hz/3 phase/30amp (per oven)					3				Removal of double convection ovens and will replace with pizza ovens. Need to consult HALTON for final conversion.
Ventless Fryer	Wells	WVAE-55F	208v/30amp/3phase							1		We will relocate fridge next to sink and place fryer next to other fryer in a line
TV Screens			110/120v/50/50hz	10	10	10	10	10	10		10	Fascia of each stand. Some locations have existing power for existing signage
DMP Player				10	10	10	10	10	10		10	Fascia of each stand. Some locations have existing power for existing signage

FRYERS

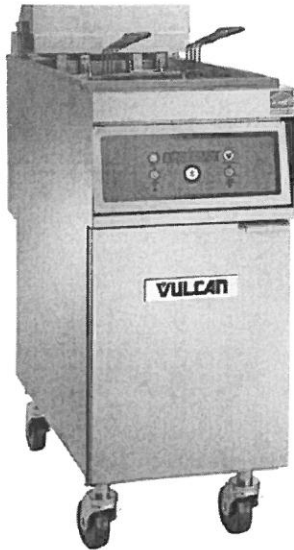
VULCAN**1ER50 SERIES
FREE STANDING ELECTRIC FRYERS**

Model 1ER50D
Shown with caster accessory

**SPECIFICATIONS**

Electric deep fat fryer, Vulcan Model No. (1ER50A) (1ER50D) (1ER50C) temperature controls are adjustable from 200°F to 390°F and multiple fat melt cycles and high limit control. Stainless steel cabinet with four 6" adjustable legs. 16 gauge stainless steel fry tank, 50 lbs. of frying compound. 1 1/4" full port ball type drain valve. 17kW low watt density ribbon style heating elements. Twin fry baskets. Power supply is 208 volt, 50/60 Hz, 3 phase.

Overall Dimensions:

15 1/2" w x 34 3/8" d x 39 1/8" h. working height is 35 3/4".

NSF listed. CSA design certified.

Specify voltage when ordering.

- 1ER50A** Solid state analog knob control.
- 1ER50D** Solid state digital controls.
- 1ER50C** Programmable computer controls.

STANDARD FEATURES

- Stainless steel cabinet.
- Set of four 6" adjustable legs.
- 16 gauge stainless steel fry tank, 50 lb. capacity.
- Ten year limited fry tank warranty.
- 1 1/4" full port ball type drain valve.
- 17 kW low watt density ribbon style heating elements.
- Multiple fat melt modes.
- High limit control.
- Twin fry baskets with plastic coated handles.
- 208 volt, 3 phase.
- One year limited parts and labor warranty.

CONTROLS

- 1ER50A** Solid state knob control. Accurate temperature control 200°F to 390°F within +/- 2°. Multiple fat melt modes, fast recovery.
- 1ER50D** Solid state digital read temperature control. Accurate temperature control 200°F to 390°F within +/- 2°. Multiple fat melt modes, fast recovery and boil out mode and two countdown timers.
- 1ER50C** Computer control digital read temperature control. Accurate temperature control 200°F to 390°F within +/- 2°. Multiple fat melt modes, fast recovery and boil out mode. Ten programmable product keys and ten countdown timers. Secondary and advanced programming options.

OPTIONAL FEATURES (Factory Installed)

- Second year extended limited parts and labor warranty.

ACCESSORIES (Packaged & Sold Separately)

- Stainless Steel Tank Cover – doubles as a work surface top
- Set of four 6" adjustable casters (2 locking)
- Extra set of Twin Fry Baskets – 6 1/2" w x 13 1/4" d x 6" h
- Large Single Fry Basket – 13" w x 13 1/4" d x 5 1/2" h
- Frymate™ VX15S Dump Station
- Connecting Kit(s) – connect two fryers together (banking strip, brackets and hardware)
- 10" high stainless steel removable splash guard

VULCAN

a division of ITW Food Equipment Group LLC

P.O. Box 696 ■ Louisville, KY 40201 ■ Toll-free: 1-800-814-2028 ■ Local: 502-778-2791 ■ Quote & Order Fax: 1-800-444-0602

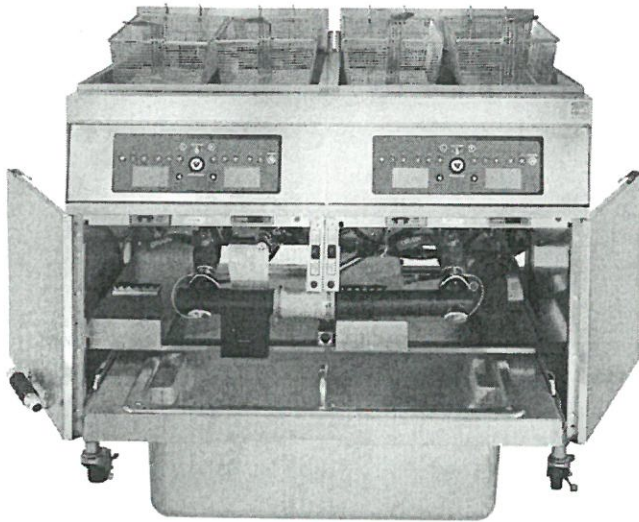
VULCAN**ER KLEENSCREEN PLUS® FILTRATION SYSTEM
BUILT-IN FILTRATION SYSTEM FOR 2ERF, 3ERF & 4ERF FRYERS**

Model 2ER85CF
Shown on casters (Accessory)

**SPECIFICATIONS**

Built-in filter system, Vulcan Model No. (# of fryers – 2, 3 or 4) ER50 (control type A, D, or C) F (add suffix -F to fryer battery Model No., i.e. 2ER50DF). Filter system accommodates a maximum of four cabinets. Drawer style filter pan assembly holds 70 lbs. shortening capacity. Filter vessel constructed of drawn (seamless) 18 gauge stainless steel. The 2ER50F filter pan weighs only 12.2 lbs. 1/3 H.P. motor and pump circulates hot frying compound at the rate of 8 gallons per minute, activated by a one touch push button switch. System provided standard with stainless steel mesh filter screen. Optional KleenScreen PLUS® envelopes filter out particulate down to .5 microns. Standard equipment comes on legs, has a tank brush and cleanout rod. Hands free oil return line connection. Drain valve interlock switch turns fryer's heating elements off when drain valve is opened. Power supply is 208 volt, 60 Hz, 3 phase.

CSA design certified. NSF listed.

STANDARD FEATURES

- Filter system accommodates maximum of four fryer cabinets.
- Boil Out ByPass™ easily removes boil out solution from fry tank without contact of drain manifold, filter pan or motor/pump.
- Drain valve interlock switch (DVI). Turns off heating elements automatically when draining oil or lifting heating elements during cleaning.
- 18 gauge stainless steel filter pan. 70 lbs. frying compound capacity.
- 6" adjustable legs.
- Stainless steel mesh 2-sided filter screen – surface area 270 sq. in.
- 1/3 H.P. motor and pump circulates frying compound at a rate of 8.0 gallons per minute.
- One touch push button switch to engage pump and motor (solid state controls).
- Tank brush and clean-out rod.
- One year limited parts and labor warranty.
- 6' High Temperature Discard Hose.
- 10 year fry tank limited warranty.

ACCESSORIES (Packaged & Sold Separately)

- Stainless steel tank cover – doubles as a work surface top.
- Micro-Filtration Fabric Envelopes – 6 filters/per package.
- Casters, adjustable (2 locking, 2 non-locking).
- "Add-On" Frymate™ – VX15.
- Rear oil reclamation discard connection (factory installed).
- Prison Security Package (factory installed).
- Single Basket Lift (factory installed).

OPTIONS

- Second year extended limited parts and labor warranty.

REFERENCE MATERIALS

- See 1ER50 Spec Sheet F32900 for electrical specs.
- See 1ERF Spec Sheet F32969 for single unit KleenScreen PLUS®.

VULCAN

a division of ITW Food Equipment Group LLC

P.O. Box 696 ■ Louisville, KY 40201 ■ Toll-free: 1-800-814-2028 ■ Local: 502-778-2791 ■ Quote & Order Fax: 1-800-444-0602

FRYERS



**ER KLEENSCREEN PLUS® FILTRATION SYSTEM
BUILT-IN FILTRATION SYSTEM FOR 2ERF, 3ERF & 4ERF FRYERS**

INSTALLATION INSTRUCTIONS

1. An adequate ventilation system is required for Commercial Cooking Equipment. Information may be obtained by writing to the National Fire Protection Association, Batterymarch Park, Quincy, MA 02269. When writing refer to NFPA No. 96.
2. All models require a 6" clearance at both sides and rear adjacent to combustible construction.
3. All models require a 16" (407 mm) minimum clearance to adjacent open top burner units.
4. This appliance is manufactured for commercial installation only and is not intended for home use.

SERVICE CONNECTIONS:

1. Each tank requires it's own separate power supply.
2. Power supply for basket lifts and/or filter motor is wired into the fryer's high voltage line terminal block, except for 480V which requires a separate 120V single phase electrical power connection NEMA 5-15P service for the basket lifts and filter motor, (not supplied with fryer).

NOTE: In line with its policy to continually improve its product, Vulcan reserves the right to change materials and specifications without notice.

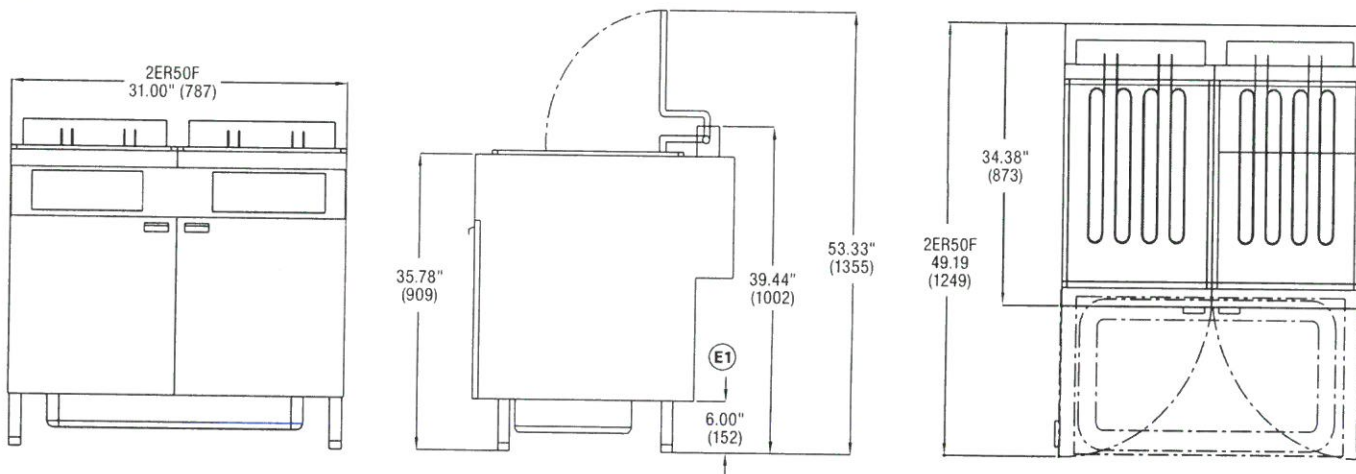

FILTER SYSTEM SPECIFICATION:

Screen = 220 sq.
Micro Filtration Fabric Envelope = 220 sq. in

MOTOR/PUMP SPECIFICATIONS:

480V = 1/3 HP 1750 RPM 8.0 gal./min 120V / 5.0A 50/60Hz 1 Ph.
208V = 1/3 HP 1750 RPM 8.0 gal./min 208V / 3.6A 50/60Hz 1 Ph.

Model	Filter Pan Capacity	Electrical	Battery Dimensions (Widths)		
			2 Fryers	3 Fryers	4 Fryers
2ER50F	70 lbs.	17kW Refer to spec. sheet F32900	31"	46½"	62"
3ER50F					
4ER50F					

NOTE: Fryer in battery with fuses (master) must add 5 amps for the motor / pump. Remaining fryers (slave) use amps per spec. sheet.

This appliance is manufactured for commercial use only and is not intended for home use.



a division of ITW Food Equipment Group LLC

P.O. Box 696 ■ Louisville, KY 40201 ■ Toll-free: 1-800-814-2028 ■ Local: 502-778-2791 ■ Quote & Order Fax: 1-800-444-0602



1100 Series Impinger® II Conveyorized Oven

1100 Series Impinger® II Conveyorized Oven

Models

- | | | | | |
|-------------------------------------|--|-------------------------------------|-------------------------------------|-------------------------------------|
| <input type="checkbox"/> 1116-xxx-U | <input type="checkbox"/> 1131-xxx-U | <input type="checkbox"/> 1134-xxx-N | <input type="checkbox"/> 1155-xxx-E | <input type="checkbox"/> 1164-xxx-E |
| <input type="checkbox"/> 1117-xxx-U | <input checked="" type="checkbox"/> 1132-xxx-U | <input type="checkbox"/> 1151-xxx-N | <input type="checkbox"/> 1157-xxx-N | |
| <input type="checkbox"/> 1130-xxx-U | <input type="checkbox"/> 1133-xxx-U | <input type="checkbox"/> 1154-xxx-E | <input type="checkbox"/> 1158-xxx-N | |

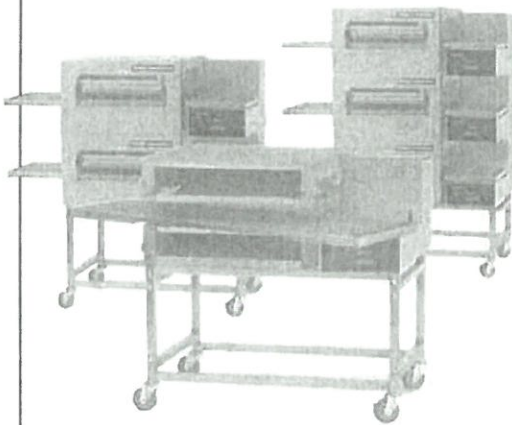

Benefits

- Faster bake times improve time of service.
- Advanced air impingement technology enhances bake quality and uniformity.
- Front removable conveyor for improved cleaning in tight spaces.
- Research and applications support for continued operational success.
- Manitowoc Star Service Support is committed to ongoing customer satisfaction.
- FastBake™ Technology designed to bake up to 35% faster than other conveyor ovens without increased noise levels or loss of product quality! (Optional)

Standard Features:

- Customer specific finger setups provide menu flexibility
- Stackable up to three (3) high.
- 18" (457 mm) wide, 56" (1422 mm) long conveyor belt with product stop
- 28" (711 mm) baking chamber
- Temperature adjustable from 250°F to 575°F (121-302°C).
- Conveyor speed is adjustable from one (1) minute to thirty (30) minutes cooking time
- Stainless steel top, front and sides.
- Oven start-up/check-out by Manitowoc STAR authorized service agent included in price
- Digital controls
- Front-loading glass access door with cool to the touch handle
- Front removable conveyor for easy cleaning
- Reversible conveyor

Specifications

Lincoln *Impinger* Conveyor Ovens are the premier continuous cook platform for the food service industry. Using the latest advancements in air Impingement technology, *Impinger* ovens allow for rapid heating, cooking, baking, and crisping of foods, typically done two to four times faster than conventional ovens.

Easy to Operate:

- Digital controls with single on/off power switch.
- Microprocessor controlled bake time/conveyor speed.

- Improved view vacuum florescent readout displays set temperatures in degrees (F° or C°), conveyor belt speed, thermostat indicator light, and diagnostic messages for easy trouble shooting.
- All settings are automatically locked out to eliminate accidental changes.

Easy to Clean:

- Front loading conveyor and removable door make it the easiest oven to clean in the industry.

Optional Features:

- *FastBake*: Improve your bake time by up to 35% without increased noise levels or loss of product quality!
- Entry and exit shelves
- Flexible gas connector.
- Split belt



1111 N. Hadley Rd.
P.O. Box 1229
Ft. Wayne, IN 46801-1229

Tel: 888-417-5462
Fax: 800-285-9511
E mail: Info@llncofnp.com

www.llncofnp.com





Gas Supply Pressure Recommendations

Gas Type	Supply (Inlet) Pressure (mbar)	Recommended Minimum Gas Pipe Size
Natural	7-12" WC (1.7 kPa / 17.4 mbar - 2.9 kPa / 29.9 mbar)	1½" (38 mm)
LP	11-12" WC (2.7 kPa / 27.36 mbar - 2.9 kPa / 29.9 mbar)	1½" (38 mm)

*Gas supply pressures are dependent on local gas type and on all applicable local codes. Agency approved flexible connection to each oven must be minimum ¾" (19 mm) NPT and length must not exceed six (6) feet (1829 mm).

Electrical Service

Each oven deck requires voltage, phase and hertz as indicated by model number. Neutral must be grounded at electrical service and receptacle properly polarized. Gas 120V units have a cord with NEMA 5-15 plug. All other models have terminal block connections. It is recommended that a separate circuit breaker be provided for each oven deck.

Recommended Minimum Clearances

Rear of oven to Combustible Surface: 6" (152mm). Additional clearance on right hand side from other cooking equipment: 24" (610mm). The conveyor is removable from the front.

Warranty

All new *Impinger* ovens installed in the United States and Canada come with a one (1) year parts and labor warranty starting from the date of start-up/check-out. All ovens installed in locations other than in the US and Canada are warranted for one (1) year parts and ninety (90) days labor starting from the date of start-up/check-out. Start-up must occur within 24 months of date of manufacture.

General Information

All 1100 Models	Length	Depth	Height Single	Height Double Stacked	Height Triple Stacked
	56" (1422 mm)	39" (991 mm)	42" (1067 mm)	59½" (1511 mm)	62" (1575 mm)

Model Number	Agency	Utility	Input Rate	Voltage	Amps	Hertz	Phase	Supply Wires
1116-xxx-U	UL EPH/CSA	Natural	40,000 BTU/Hr. 11.7 kW/42.2 MJ	120	7	60	1	3, 1 Pole+N+G
1154-xxx-E	AGA/UL EPH/CE	Natural		230	2	50	1	3, 1 Pole+N+G
1157-xxx-N	UL EPH	Natural		220		60	1	3
1117-xxx-U	UL EPH/CSA	LP		120	7	60	1	3, 1 Pole+N+G
1155-xxx-E	AGA/UL EPH/CE	LP		230	2	50	1	3, 1 Pole+N+G
1158-xxx-N	UL EPH	LP		220		60	1	3
1130-xxx-U	UL EPH/UL/cUL	Electric	10 kW	120/208	48	60	1	4, 2 Pole+N+G
1131-xxx-U	UL EPH/UL/cUL	Electric		120/240	42	60	1	4, 2 Pole+N+G
1132-xxx-U	UL EPH/UL/cUL	Electric		208	28	60	3	4, 3 Pole+N+G
1133-xxx-U	UL EPH/UL/cUL	Electric		240	25	60	3	4, 3 Pole+N+G
1134-xxx-N	UL EPH	Electric		380/208		50	3	5
1151-xxx-N	UL EPH	Electric		200	29	50/60	3	4, 3 Pole+N+G
1164-xxx-E	CE/UL EPH	Electric		400/230	42	50	3	5, 3 Pole+N+G

NOTE: Panel setups are added as kit numbers to the end of the model number to complete the oven order (Ex. 1116-000-U-K1837 is a 1116-000-U with Standard setup, Left to Right)

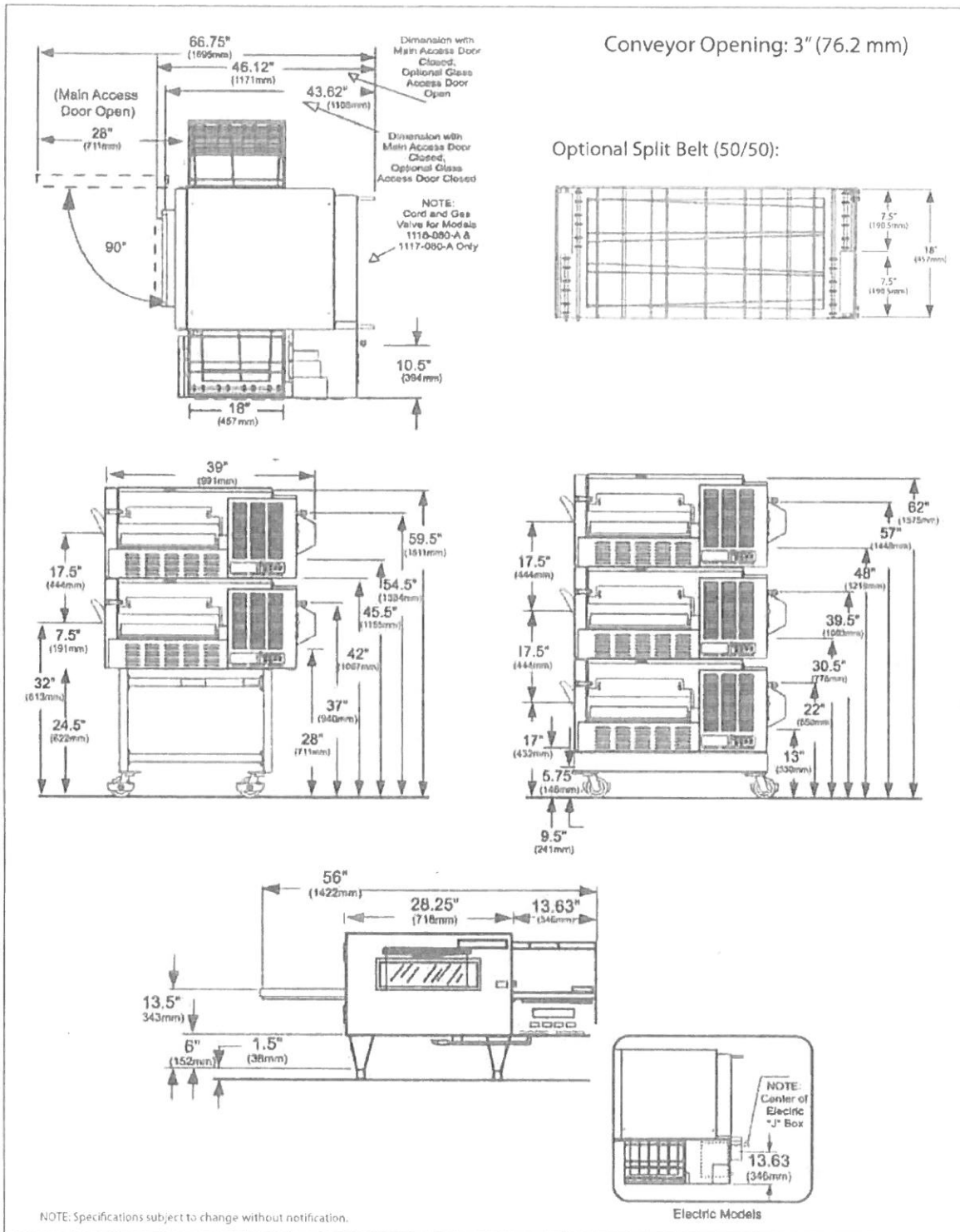

Capacity Estimates | Pies Per Hour

Pie Size	BAKE TIME								
	3 min.	3½ min.	4 min.	4½ min.	5 min.	5½ min.	6 min.	6½ min.	7 min.
12" (30 cm)	53	46	40	35	32	29	26	25	23
14" (36 cm)	41	35	31	27	25	23	21	19	18
16" (41 cm)	35	30	26	24	21	19	18	16	15

Ventilation Requirements

Ventilation is required on all gas ovens. Ventilation is not required on electric models except when triple stacked. Local codes prevail. These are the "authority having jurisdiction" as stated by the National Fire Protection Association, Inc. in NFPA 96-1994. Estimates of CFM requirements can vary from 400 to as high as 2800 CFM exhaust. In all cases, the ambient temperature around the oven must not exceed 95°F (35°C) when the oven is operating. **In the case where a gas single or double stack oven is installed, the following information can be used as a guideline for ventilation.**

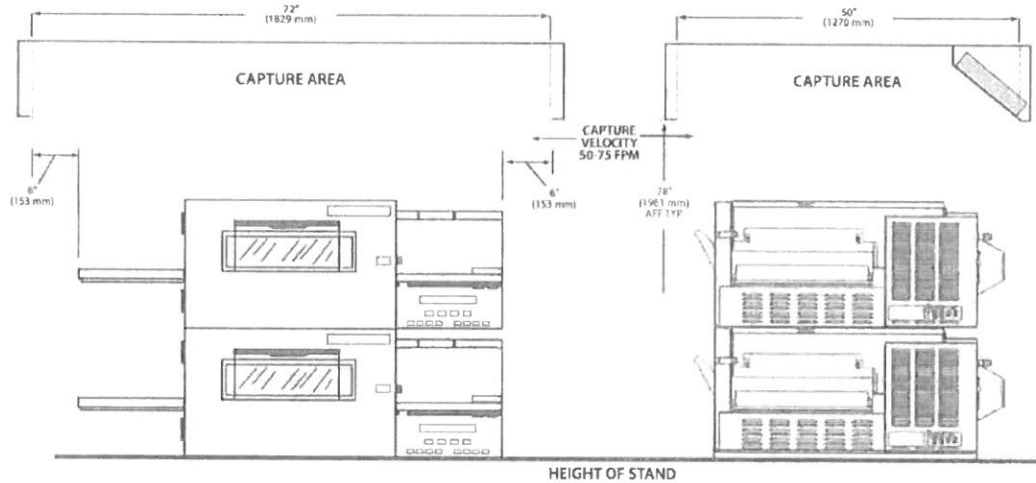

1. Double Stack: Range of 800-1200 cfm for double gas 1100 series oven.
Single Stack: Range of 450-800 cfm for single gas 1100 series oven.
2. The capture velocity across the apron of canopy is to be 50-75 FPM at sides and front.
3. Double Stack: Width should be 72" (1828 mm) - inside dimensions. Depth should be 50" (1270 mm) - inside front to filters.
Single Stack: Width should be 48" (1219 mm) - inside dimension. Depth should be 50" (1270 mm) - inside front to filters.
4. The ovens are to be centered in the canopy space left-to-right and front-to-back if possible.
5. Room air diffusers must not be directed onto the oven and should be positioned a minimum of 3 feet from the perimeter of the hood to keep them from affecting the oven.
6. Bottom of canopy should be 78" (1981 mm) above finished floor (AFF).
7. Recommend 70% make-up air provided outside of the canopy through perf metal diffusers directed straight down... not at the oven; located at front, sides or both.
8. Use of a Type I or Type II application and overall final installation is determined per local codes.

NOTE: Specifications subject to change without notification.

1111 N. Hadley Rd.
P.O. Box 1229
Ft. Wayne, IN 46801-1229

Tel: 888-417-5462
Fax: 800-285-9511
E mail: info@lincolnfp.com

www.lincolnfp.com





Global

Ventless 1100 Series Impinger® II Conveyorized Oven

Ventless 1100 Series Impinger® II Conveyorized Oven

Models

- 1130-xxx-V 1131-xxx-V 1132-xxx-V 1133-xxx-V

**New
For Ventless
Applications**

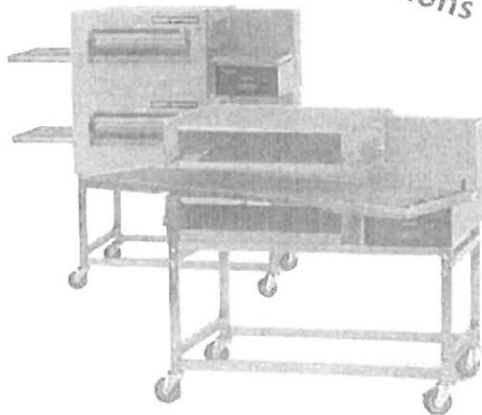

Benefits

Ventless Installation*

- Increased installation flexibility
- Lower installation costs

Faster Bake Times - with FastBake Technology

- Improved Response to Customer
- FastBake Reduces Cook Time by Up to An Additional 35% With No Food Quality Loss or Noise Increase

Easier Operation

- Digital Controls with Single On/Off Switch
- Microprocessor Controlled Bake Time/Conveyor Speed
- Locked Setting to Prevent Unintended Changes
- Fluorescent Display Indicating Temperature, Belt Speed, Thermostat, and Diagnostic Messages

Easier Cleaning

- Front Load Conveyor
- Removable Door

Unparalleled Support

- Customer-specific Finger Setup for Menu Flexibility
- Research and Applications Team Help Achieve Ideal Cooking Results
- Manitowoc Star Service Committed to Owner Satisfaction

Specifications

General

Stainless Steel Top, Front and Sides
28" (711mm) Long Baking Chamber
Front Removable Fingers
Stackable Up To Two High
Includes Oven Start-Up/Check-Out
by Manitowoc STAR Authorized
Service Agent

Conveyor

18" (457mm) Wide
Front Removable
Product Stop
One to Thirty Minute Cook Time
Reversible

Cooking

FastBake Technology Reduces Cook Time
by Up to An Additional 35% With No
Food Quality Loss or Noise Increase
Customer Specific Finger Setup
Temperature Range 250°F to 575°F
(121°C to 302°C)
Front Loading Glass Access Door
with Cool to the Touch Handle
Digital Controls

Optional

Entry and Exit Shelves
Split Belt

Ventless Operation*

UL Category KNLZ Listed*



* Local Code Prevails

18301 St. Clair Street
Cleveland, OH 44110

Tel: 888-417-5462
Fax: 800-285-9511
E mail: Info@lincolnfp.com

www.lincolnfp.com
LIN_5078 8/25/16





Electrical Service

Each oven deck requires voltage, phase and hertz as indicated by model number. Neutral must be grounded at electrical service and receptacle properly polarized. All ventless models have terminal block connections. It is recommended that a separate circuit breaker be provided for each oven deck.

Ventilation

Ventilation is not required with the "V" version of the 1100. The product is UL Certified and UL Category KNLZ Listed for ventless operation. Of course, local codes prevail as stated in the NFPA 963-1994 regulations.

Recommended Minimum Clearances

Rear of oven to Combustible Surface: 6" (152mm). Additional clearance on right hand side from other cooking equipment: 24" (610mm). The conveyor is removable from the front.

Warranty

All new *Impinger* ovens installed in the United States and Canada come with a one (1) year parts and labor warranty starting from the date of start-up/check-out. All ovens installed in locations other than in the US and Canada are warranted for one (1) year parts and ninety (90) days labor starting from the date of start-up/check-out. Start-up must occur within 24 months of date of manufacture.

General Information

All 1100 Models		Length	Depth	Height Single	Height Double Stacked	Height Triple Stacked			
		56" (1422 mm)	39" (991 mm)	42" (1067 mm)	59½" (1511 mm)	62" (1575 mm)			
Model Number	Agency	Utility	Input Rate	Voltage	Amps	Hertz	Phase	Supply Wires	
1130-xxx-V	UL EPH/UL/cUL	Electric	10 kW	120/208	48	60	1	3, 2 Pole+G	
1131-xxx-V	UL EPH/UL/cUL	Electric		240	42	60	1	3, 2 Pole+G	
1132-xxx-V	UL EPH/UL/cUL	Electric		120/208	28	60	3	4, 3 Pole+G	
1133-xxx-V	UL EPH/UL/cUL	Electric		240	25	60	3	4, 3 Pole+G	

NOTE: Panel setups are added as kit numbers to the end of the model number to complete the oven order (Ex: 1130-000-V-K1837 is a 1130-000-V with a standard setup, left to right)

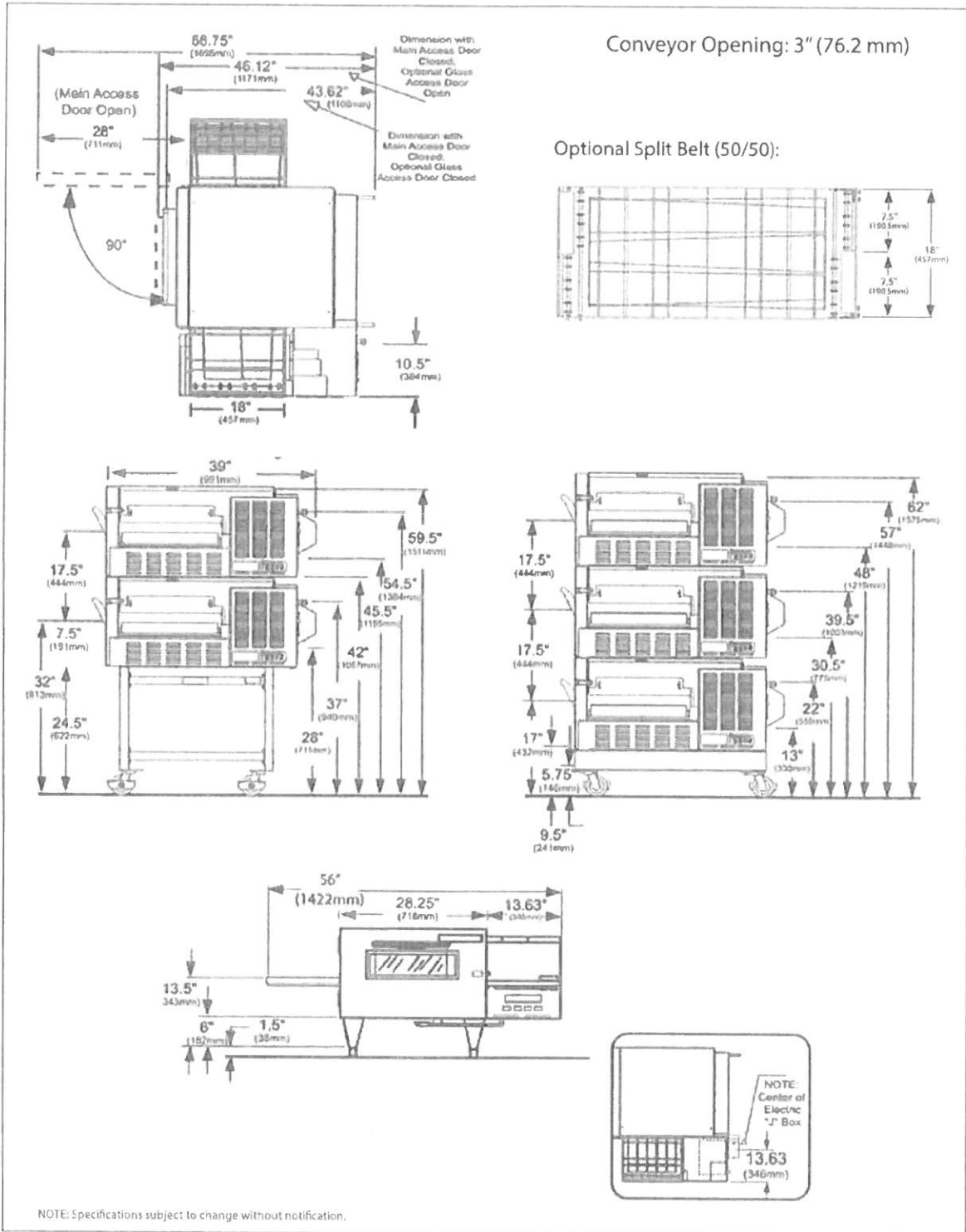



Global

Ventless 1100 Series Impinger® II Conveyorized Oven

Capacity Estimates | Pies Per Hour

Pie Size	BAKE TIME								
	3 min.	3½ min.	4 min.	4½ min.	5 min.	5½ min.	6 min.	6½ min.	7 min.
12" (30 cm)	53	46	40	35	32	29	26	25	23
14" (36 cm)	41	35	31	27	25	23	21	19	18
16" (41 cm)	35	30	26	24	21	19	18	16	15

Ventilation Requirements

Ventilation is not required except when triple stacked. The product is UL Certified and UL Category KNLZ Listed for ventless operation. Local codes prevail. These are the "authority having jurisdiction" as stated by the National Fire Protection Association, Inc. in NFPA 96-1994. In all cases, the ambient temperature around the oven must not exceed 95°F (35°C) when the oven is operating.

18301 St. Clair Street
Cleveland, OH 44110

Tel: 888-417-5462
Fax: 800-285-9511
E mail: Info@lincolnfp.com

www.lincolnfp.com
LIN_5078 8/25/16



INSULATED STAINLESS STEEL HOT CABINET MODEL H-137-SUA-12D

FEATURES AND BENEFITS:

- Fully insulated hot cabinet keeps prepared foods at serving temperatures.
- Powerful, yet efficient, 1500 Watt heating system maintains the right temperature to properly hold products. Heats up to 200°F (93°C).
- Standard solid state electronic control with large, clear, easy-to-read and operate LED digital display to ensure holding at precise food temperature.
- Internal frame in body maintains structural rigidity.
- Stainless steel construction throughout for ease of cleaning. One piece extended base protects cabinet body.
- Smooth interior coved corners prevent food particle/grease buildup.
- Safety-conscious anti-microbial latches protect against spreading germs.
- Field reversible insulated Dutch doors prevent temperature loss. Silicone door gaskets for proper seal.
- Standard with right hand hinging; left hand hinging available upon request.
- High temperature ceramic magnetic latches for "easy open"; twist-lock catch secures door during transport.
- Recessed push/pull handles on both sides prevent damage to walls; allows easy maneuvering.
- Twelve sets of chrome plated wire universal angles accommodate a large variety of pan sizes on adjustable 1-1/2" centers.
- Heavy duty 5" swivel casters, two with brakes. Provides mobility when fully loaded.

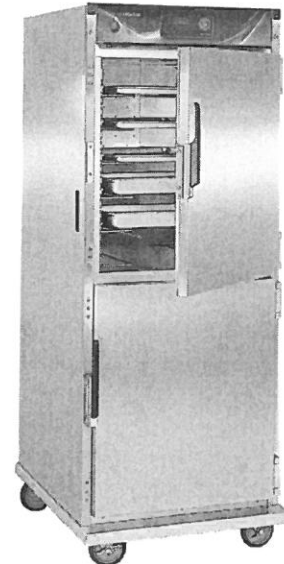

H-137-SUA-12D



Standard solid state electronic control with large, clear, easy-to-read and operate LED digital display to ensure holding at precise food temperature

ACCESSORIES and OPTIONS (Available at extra cost):

- Tempered Glass Door Windows
- Key Lock Handles
- Lock Hasp
- Extra Universal Angles
- Change from standard chrome plated wire angles to angles designed for transporting
- Corner Bumpers
- Perimeter Bumper
- Rear Push Handle
- Bail Handles
- Various Caster Options
- Removable Cord Set
- 208 or 240 Volt Service
- Upgrade to 2000 Watts Power Unit

See page B-30 for accessory details.



H-137-SUA-12D

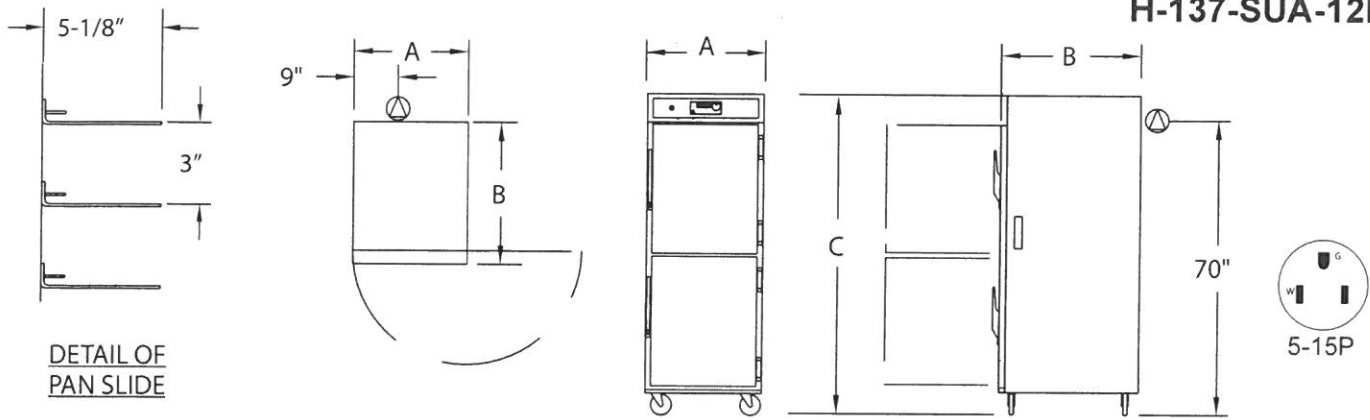

CRES COR MODEL NO.	PAN			DIM "A"	DIM "B"	DIM "C"	INSIDE DIMENSIONS			WEIGHT ACT.	
	CAP/ ANGLES	SIZE		WIDTH	DEPTH	HEIGHT	WIDTH	DEPTH	HEIGHT		
H-137-SUA-12D	12 SETS	SEE NOTE BELOW	IN	28-3/4	32-3/4	73	22	26-7/8	58	LBS	283
			MM	730	835	1855	560	685	1475	KG	128

NOTES: 1. Pan sizes 22" x 20" (560 x 510) Roast & Bake Pans, 10" x 20" (255 x 510) Roast & Bake Pans, 18" x 26" (460 x 660) Bun Pans, 14" x 18" (355 x 460) Service Trays, 12" x 20" (305 x 510) Steam Table Pans. Refer to Pan Size Chart at end of section.

2. When ordering bumpers, add 2" to overall dimensions.



Gold indicates our Best Insulated Hot Cabinets with the best warranty in the industry. 3-Year Parts / 1-Year Labor.

CABINET:

- Body: 22 ga. stainless steel.
- Reinforcement: Internal framework of 18 ga. stainless steel.
- Insulation: Fiberglass, thermal conductivity (K factor) is .23 at 75°F. 1-1/2" in doors, base top; 2" in sidewalls.
- Air tunnels: 22 ga. stainless steel; lift-out type, mounted on sides.
- Push/pull handles (2): 5" vertical; recessed.
- Interior coved corners.

BASE:

- One piece construction, .125 aluminum.
- Casters: 5" dia., swivel, modulus tires, 1-1/4 wide, load cap. 250 lbs. each, temp. range -45°/+180°F. Delrin bearings. Front casters equipped with brakes.

DUTCH DOORS:

- Field reversible.
- Formed 22 ga. stainless steel.
- Latches: Chrome plated zinc, high temperature ceramic magnetic type, mounted inboard.
- Transport Latches.
- Hinges: Heavy duty chrome plated zinc.
- Gaskets: Perimeter type, silicone.
- Pan stops: Embossed.

PAN SLIDES:

- Wire angles (.306 dia.), nickel chrome plated steel, mounted on lift-off posts.
- Spaced on 4-1/2" centers; adjustable on 1-1/2" centers.



Scan QR code to view Spec Sheet, Operating Manual, Wiring Diagram or to call Customer Service.

If you need a QR reader visit your App Store on your Smartphone or Tablet.

HOT UNIT COMPONENTS:

- Thermostat: Solid state digital display control, room ambient to 200°F (93°C).
- Switch: ON-OFF push button type.
- Power cord: Permanent, 10 ft., 14/3 ga.
- Heater: 1470 Watts.
- Blower motor.
- Vent Fan.
- Thermometer: Digital.

POWER REQUIREMENTS:

- 1500 Watts, 120 Volts, 60 Hz., single phase, 12 Amps., 15 Amp. service.

SHORT FORM SPECIFICATIONS

Cres Cor Insulated Hot Cabinet Model H-137-SUA-12D. Solid state electronic controlled time and temperatures. Cabinet 22 ga. stainless steel; stainless steel internal frame. (12) sets wire universal angles for multiple pan sizes, adjustable spacing every 1-1/2". Field reversible Dutch doors, 22 ga. stainless steel. Fiberglass insulation in sides, 2"; doors, base, top 1-1/2". Interior coved corners. 1500 Watt, 120 Volt power unit. One piece insulated base, .125 aluminum. 5" swivel modulus casters, Delrin bearings. Load capacity 250 lbs. each. 3-Year Parts / 1-Year Labor warranty. Provide the following accessories: _____ . CSA-US, CSA-C listed. Energy Star Qualified.



5925 Heisley Road • Mentor, OH 44060-1833
Phone: 877/CRESCOR • Fax: 440/350-7267
www.crescor.com

© Crescent Metal Products, Inc. 2017 All rights reserved.

In line with its policy to continually improve its products, CRES COR reserves the right to change materials and specifications without notice.

Made in America Since 1936

WVAE-55F, WVAE-55FS VENTLESS FRYER

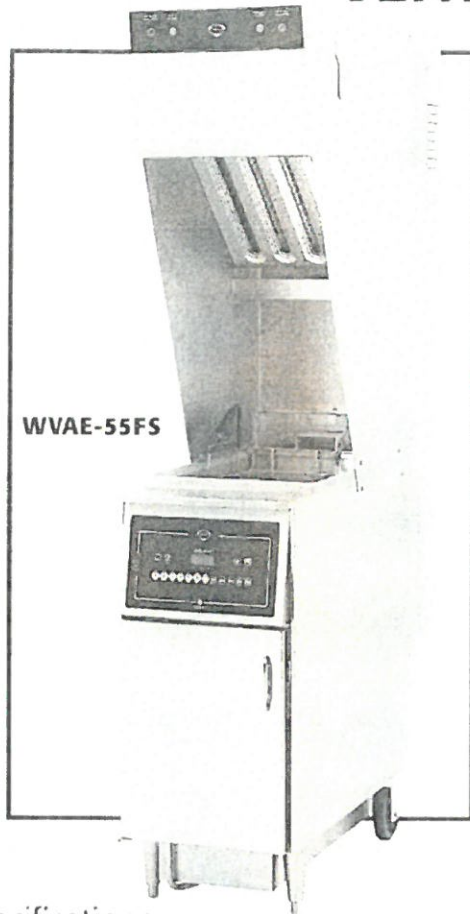

Features

- **Ventless Hood System** exceeds EPA Standard 202 for the release of particulate matter.
- **Air Filter Interlock System** will not allow heating element to be energized if the baffle or HEPA filter is not in place.
- **Airflow Sensing System** is designed to monitor airflow through the filtration system to optimize grease removal efficiency.
- **The system warning light** will indicate when the HEPA filter needs to be replaced.
- **Ansul R-102 Fire Suppression** is built into the Ventless Hood using a unique anti-fire design.
- **The solid state control** on the WVAE-55FS incorporates a seven key programmable time and temperature menu.
- **Repeat cycle timer** activates using one push button operation.
- **Paperless filtration system** reduces labor and cleans oil more efficiently, and combined with Flavor Saver Filter Powder will **substantially increase oil life**.
- **Automatic basket lift cradle** raises basket above oil at end of timed cook cycle, maximizing handling safety.
- **Flat bar elements**, located below the basket, are heavy-duty stainless steel with a low watt density for longer oil life.
- **Frypot** is constructed of stainless steel and robotically welded for durability.
- **The WVAE-55F and WVAE-55FS fryers** are Underwriters Laboratories, Inc. LISTED and meet NSF International standards.
- **A one-year warranty** against defects covers parts and labor.

Specifications

Overall Dimensions:	Inches	MM
Width	15 13/16	401
Depth	43 11/16	1110
Height (incl. 4" legs)	76 3/8	1940
Oil Capacity:	Lbs.	KG
WVAE-55F/FS	55	25
Typical Production:	Lbs.	KG
Chicken <i>frozen</i>	25*	11
Chicken <i>fresh</i>	33*	15
*With standard basket only		
Weights:	Lbs.	KG
Installed	425	193
Shipping	525	238

Export

The following models are available for export and meet the standards for CE:

- WVAE-55FEU, 380-415VAC, 3Ø, 17400 watts
- WVAE-55FSEU, 380-415VAC, 3Ø, 17400 watts

Accessories / Options

- HEPA Filter, fits all ventless fryers, 22402
- Charcoal Filter, fits all ventless fryers, 22403
- Flavor Saver Oil Filter Powder, 45 packs, 22410
- Rear Leg Kit, for remote pull, 22692
- Half-Size Baskets Available

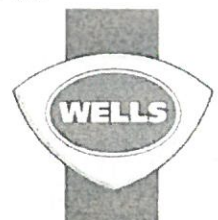

WELLS MANUFACTURING



MODEL WVAE-55F FRYERS

DIMENSIONS:

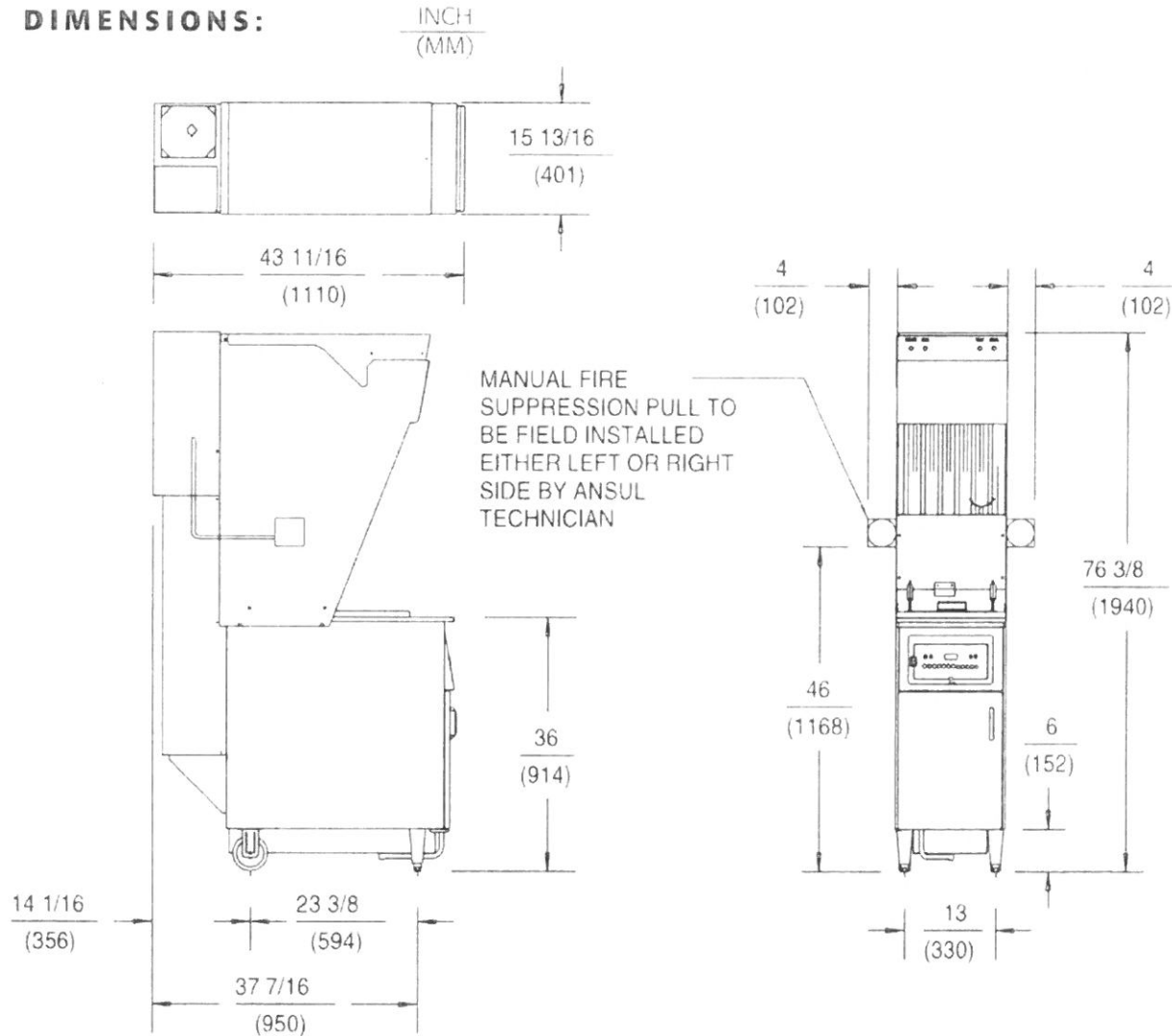

WVAE-55F ELECTRICAL SPECIFICATIONS:

MODELS	VOLTS	WATTS	AMPS PER LINE PHASE 3				AMPS SINGLE PHASE	POWER SUPPLY CORD
			L1	L2	L3	N		
WVAE-55F	208	17000	47.8	47.2	47.8	NA	NA	NONE
WVAE-55F	240	17000	41.5	41.0	41.5	NA	NA	NONE
WVAE-55FEU	380-415	17400	26.0	24.0	24.0	3.0	NA	NONE

All models with an 'S' suffix have the same electrical specifications as the standard units.

NOTE: Specifications are subject to change without notice.

Denotes export (EU) products.

SPECIAL ENVIRONMENTAL NOTICE: The hood system is designed to reduce odor emissions but will not eliminate odors. Air exchange at the installation site must comply with requirements of the local jurisdictional authority. To ensure dilution of odor build-up, minimum recommendation is 400 cubic feet of fresh air per minute both in and out of the area.

WELLS MANUFACTURING COMPANY

2 ERIK CIRCLE, PO BOX 280, VERDI, NV 89439 U.S.A. • USA PHONE: (775) 689-5700 • FAX: (775) 689-5972

FOR ORDERS ONLY: (888) 356-5362 • FAX: (800) 356-5142 • www.wellsbloomfield.com

©2001 WELLS MANUFACTURING • PRINTED IN THE U.S.A. • 03/01 • REV(C) • PART NO. 302022

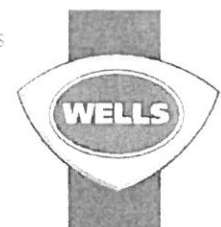



Glo-Ray® Fry Holding Station

Models: GRFHS-16, -21, -22, -26, -PTT21, -PT16, -PT26

GRFHS-16, -21, -22, -26

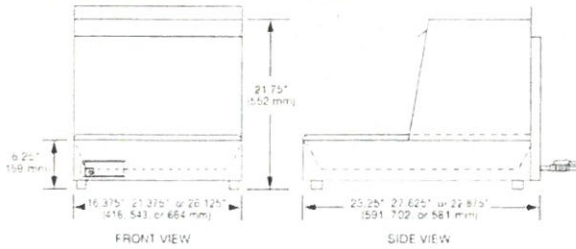

GRFHS-PTT21

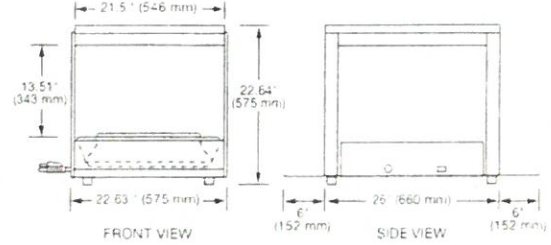

GRFHS-PT16, -PT26

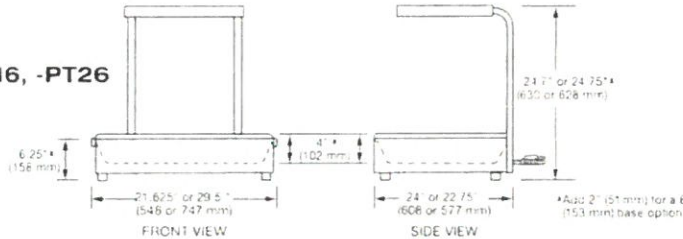

SPECIFICATIONS

Glo-Ray Fry Holding Station

The shaded areas contain electrical information for International models only

Model	Dimensions (Width x Depth x Height)	Volts	Phase	Watts	Amps	Plug	Ship Weight*
GRFHS-16	16.38" x 23.21" x 22.75" (416 x 590 x 577 mm)	100	Single	878	8.8	NEMA 5-15P	63 lbs. (29 kg)
		120		1090	9.1	NEMA 5-15P	
		220-230 (CE)		1057-1155	4.8-5.0	CEE 7/7 Schuko	
		230-240 (CE)		1019-1110	4.4-4.6	BS-1363 or AS 3112*	
GRFHS-PT16	21.58" x 23.95" x 24.875" (548 x 608 x 632 mm)	120	Single	1090	9.1	NEMA 5-15P	60 lbs. (27 kg)
GRFHS-21	21.37" x 27.58" x 22.75" (543 x 701 x 577 mm)	100	Single	1007	10.1	NEMA 5-15P	63 lbs. (29 kg)
		120		1200	10.0	NEMA 5-15P	
		220-230 (CE)		1218-1332	5.5-5.8	CEE 7/7 Schuko	
		230-240 (CE)		1102-1200	4.8-5.0	BS-1363 or AS 3112*	
GRFHS-PTT21	22.63" x 38" x 22.64" (575 x 965 x 575 mm)	120	Single	1740	14.5	NEMA 5-15P†	100 lbs. (45 kg)
		220-230 (CE)		1486-1624	6.8-7.1	CEE 7/7 Schuko	
		230-240 (CE)		1624-1768	7.1-7.4	BS-1363 or AS 3112*	
GRFHS-22	22" x 18.5" x 17.25" (559 x 470 x 439 mm)	120	Single	1030	8.6	NEMA 5-15P	44 lbs. (20 kg)
GRFHS-26	26.1" x 22.86" x 21.75" (663 x 581 x 553 mm)	100	Single	1007	10.1	NEMA 5-15P	66 lbs. (30 kg)
		120		1200	10.0	NEMA 5-15P	
		220-230 (CE)		1243-1359	5.7-5.9	CEE 7/7 Schuko	
		230-240 (CE)		1128-1229	4.9-5.1	BS-1363 or AS 3112*	
GRFHS-PT26	29.4" x 22.71" x 24.71" (747 x 577 x 628 mm)	120	Single	1440	12.0	NEMA 5-15P	64 lbs. (29 kg)
		220-230 (CE)		1233-1347	5.6-5.9	CEE 7/7 Schuko	
		230-240 (CE)		1347-1468	5.9-6.1	BS-1363 or AS 3112*	

* Shipping weight includes packaging.

† AS3112 plug for use in Australia only.

‡ The GRFHS-PTT21 for Canada uses a NEMA 5-20P plug configuration.

CORD LOCATION

GRFHS-16, -21, -26, -PT26: Back side, lower right corner.

GRFHS-PTT21: Lower right-hand side.

PLUG CONFIGURATIONS

NEMA 5-15P

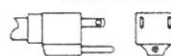

NEMA 6-15P

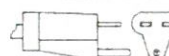

CEE 7/7 Schuko



BS-1363



PRODUCT SPECS

Glo-Ray® Fry Holding Station

The Glo-Ray Fry Holding Station shall be a Glo-Ray® Model ... as manufactured by the Hatco Corporation, Milwaukee, WI 53234 U.S.A.

The Fry Holding Station shall be rated at ... watts, ... volts, and be ... inches (millimeters) in overall width. It shall consist of either a stainless steel housing or an

aluminum housing with ceramic. Pre-set thermostatically controlled based heat. Portable warmer features wire guards, shatter-resistant incandescent display lights, a lighted on-off switch, and 6" (1829 mm) cord and plug.

Comes with 24-7 parts and service assistance (U.S. and Canada only).

HATCO CORPORATION | P.O. Box 340500 Milwaukee, WI 53234-0500 U.S.A. | (800) 558-0607 | (414) 671-6350

Fax: (800) 543-7521 | Int'l. Fax: (414) 671-3976 | www.hatcocorp.com | email: equipsales@hatcocorp.com



Glo-Ray® Fry Holding Station

Models: GRFHS-16, -21, -22, -26, -PTT21, -PT16, -PT26

Hatco offers convenient Glo-Ray® Fry Holding Stations that can be placed where they are most needed - next to a fryer! Glo-Ray heat technology offers you the ability to keep fried foods at optimum temperatures, ready to serve, without cooking or drying them out.

Standard features

- Ceramic heating elements above, allowing ample space between the warmer and food bin to empty baskets
- Pre-set thermostatically-controlled heated base maintains uniform holding temperatures from below
- Various hardcoated fry ribbons stage boxed or bagged products for quick service areas
- PT and PTT models are pass-through style
- Sectional divider permits holding of multiple products
- Models have 16.75", 18", or 20" (425, 457, or 508 mm) clearances
- Bottom trivet lifts food off the bottom of the station promoting air movement and reduces the build up of moisture
- Pass-thru tunnel is available with model GRFHS-PTT21

Project _____

Item # _____

Quantity _____



GRFHS-21
with optional right-hand cutout for fry basket and accessory fry ribbon

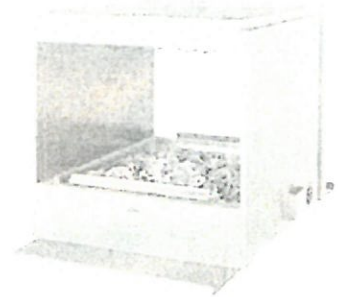

GRFHS-PTT21
with scoop holder

Options (available at time of purchase only)

- Halogen Bulb in lieu of Standard Display Light (60 watt)
- Left or Right side Cutout (GRFHS-16, -21, and -26) (Adds 1.7"(43 mm) to width of unit)
- 6" (15 mm) deep pan (GRFHS-PT26)

Accessories

- 4 Pleat Hardcoated Fry Box Ribbon (GRFHS-16 & -26)
- 5 Pleat Hardcoated Fry Bag Ribbon (GRFHS-16 & -26)
- 5 Pleat Hardcoated Fry Box Ribbon (GRFHS-21)
- 6 Pleat Hardcoated Fry Box/Bag Combo Ribbon (GRFHS-21)
- 7 Pleat Hardcoated Fry Bag Ribbon (GRFHS-21)
- 8 Pleat Hardcoated French Fry Bag Ribbon
- 8 Pleat Hardcoated Fry Box Ribbon (GRFHS-PT26 & PTT21)
- 9 Pleat Hardcoated Fry Box/Bag Combo Ribbon (GRFHS-PT26 & PTT21)
- 10 Pleat Hardcoated Fry Bag Ribbon (GRFHS-PT26 & PTT21)
- Additional Sectional Dividers (one standard per unit)
- 5" (127 mm) side-by-side bag holder (GRFHS-21)
- 5" (127 mm) piggy back bag holder (GRFHS-21 & -PTT21)
- Scoop Holder - adds 1.25" (32 mm) to overall product width for each scoop holder (one standard on GRFHS-PT26, -PTT21) (not available for the GRFHS-22)
- Food Pans (not available for the GRFHS-22)
- Wire Trivet (not available for the GRFHS-22)



HATCO CORPORATION | P.O. Box 340500 Milwaukee, WI 53234-0500 U.S.A. | (800) 558-0607 | (414) 671-6350

Fax: (800) 543-7521 | Int'l. Fax: (414) 671-3976 | www.hatcocorp.com | email: equipsales@hatcocorp.com



TRUE MANUFACTURING CO., INC.
U.S.A FOODSERVICE DIVISION

2001 East Terra Lane • O'Fallon, Missouri 63366-4434 • (636)240-2400
 Fax (636)272-2408 • Toll Free (800)325-6152 • Intl Fax# (001)636-272-7546
 Parts Dept. (800)424-TRUE • Parts Dept. Fax# (636)272-9471 • www.truemfg.com

Project Name: _____

Location: _____

Item #: _____ Qty: _____

Model #: _____

A/A #

SIS #

Model:

GDM-09-SQ-HC-LD

Glass Door Merchandiser:

Slide Door Counter-Top Squared Refrigerator with Hydrocarbon Refrigerant & LED Lighting



GDM-09-SQ-HC-LD

- ▶ The world's #1 manufacturer of glass door merchandisers.
- ▶ True's commitment to using the highest quality materials and oversized refrigeration systems provides the user with colder product temperatures, and lower utility costs in an attractive merchandiser that brilliantly displays packaged food and beverages.
- ▶ Designed for convenient access, fast service, and attractive display.
- ▶ Factory engineered, self-contained, capillary tube system using environmentally friendly R290 hydrocarbon refrigerant that has zero (0) ozone depletion potential (ODP), & three (3) global warming potential (GWP).
- ▶ High capacity, factory balanced refrigeration system that maintains cabinet temperatures of 33°F to 38°F (5°C to 3.3°C) for the best in food preservation.
- ▶ Exterior - non-peel or chip black powder coated cold rolled steel; durable and permanent.
- ▶ Interior - attractive, NSF approved, white aluminum interior liner with stainless steel floor.
- ▶ Self closing doors. Counter-balanced weight system for smooth, even, positive closing.
- ▶ "Low-E", double pane thermal insulated glass door assemblies with mitered plastic channel frames. The latest in energy efficient technology.
- ▶ LED interior lighting provides more even lighting throughout the cabinet. Safety shielded.
- ▶ Entire cabinet structure is foamed-in-place using a high density, polyurethane insulation that has zero ozone depletion potential (ODP) and zero global warming potential (GWP).

ROUGH-IN DATA

Specifications subject to change without notice.

Chart dimensions rounded up to the nearest 1/8" (millimeters rounded up to next whole number).

Model	Doors	Shelves	Cabinet Dimensions (inches) (mm)			HP	Voltage	Amps	NEMA Config.	Cord Length (total ft.) (total m)	Crated Weight (lbs.) (kg)
			W	D†	H						
GDM-09-SQ-HC-LD	2	3	36 914	22 3/8 567	39 3/4 1008	1/8 N/A	115/60/1	1.9 N/A	5-15P	9 2.74	230 105

† Depth does not include 3/8" (23 mm) for door handles.

MADE WITH INNOVATION IN THE USA
 5 YEAR WARRANTY
 UL US
 natural refrigerant
 Printed in U.S.A.

APPROVALS:

AVAILABLE AT:

Model:

GDM-09-SQ-HC-LD

Glass Door Merchandiser:

Slide Door Counter-Top Squared Refrigerator with Hydrocarbon Refrigerant & LED Lighting



STANDARD FEATURES

DESIGN

- True's commitment to using the highest quality materials and oversized refrigeration systems provides the user with colder product temperatures, and lower utility costs in an attractive merchandiser that brilliantly displays packaged food and beverages.

REFRIGERATION SYSTEM

- Factory engineered, self-contained, capillary tube system using environmentally friendly R290 hydrocarbon refrigerant that has zero (0) ozone depletion potential (ODP), & three (3) global warming potential (GWP).
- High capacity, factory balanced refrigeration system that maintains cabinet temperatures of 33°F to 38°F (.5°C to 3.3°C) for the best in food preservation.
- State of the art, electronically commutated evaporator and condenser fan motors. ECM motors operate at higher peak efficiencies and move a more consistent volume of air which produces less heat, reduces energy consumption and provides greater motor reliability.

CABINET CONSTRUCTION

- Exterior - non-peel or chip black powder coated cold rolled steel; durable and permanent.
- Interior - attractive, NSF approved, white aluminum liner with stainless steel floor.

- Insulation - entire cabinet structure is foamed-in-place using a high density, polyurethane insulation that has zero ozone depletion potential (ODP) and zero global warming potential (GWP).
- Cabinet fitted with leg levelers.
- Illuminated exterior sign panel. Variety of sign options available.

DOORS

- "Low-E", double pane thermal insulated glass door assemblies with mitered plastic channel frame. The latest in energy efficient technology.
- Each door fitted with 12" (305 mm) long handles.
- Self closing doors. Counter-balanced weight system for smooth, even, positive closing.

SHELVING

- Three (3) adjustable, heavy duty PVC coated wire shelves: two (2) 31 3/4" x 15" (807 mm x 381 mm) and one (1) 31 3/4" x 8 7/16" (807 mm x 215 mm). Four (4) chrome plated shelf clips included per shelf.
- Shelf support pilasters made of same material as cabinet interior; shelves are adjustable on 1/2" (13 mm) increments.

LIGHTING

- LED interior lighting provides more even lighting throughout the cabinet. Safety shielded.

MODEL FEATURES

- Evaporator is epoxy coated to eliminate the potential of corrosion.
- See our website www.truemfg.com for latest color and sign offerings.
- NSF/ANSI Standard 7 compliant for the storage and/or display of packaged or bottled product.

ELECTRICAL

- Unit completely pre-wired at factory and ready for final connection to a 115/60/1 phase, 15 amp dedicated outlet. Cord and plug set included.



115/60/1
NEMA-5-15R

OPTIONAL FEATURES/ACCESSORIES

Upcharge and lead times may apply.

- 2 1/2" (64 mm) legs
- White exterior
- Stainless steel exterior model available
- Ratchet locks
- Barrel locks
- Additional shelving
- Gravity feed 20oz. Bottle display system

PLAN VIEW

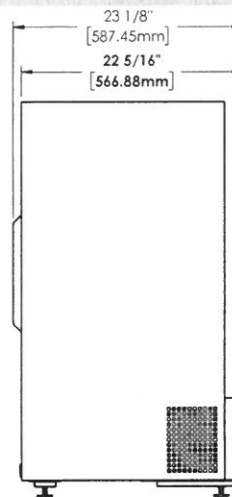
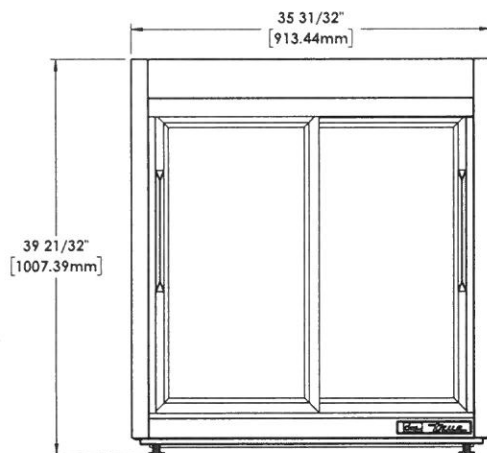

WARRANTY

Three year warranty on all parts and labor and an additional 2 year warranty on compressor. (U.S.A. only)

METRIC DIMENSIONS ROUNDED UP TO THE NEAREST WHOLE MILLIMETER

SPECIFICATIONS SUBJECT TO CHANGE WITHOUT NOTICE



Model	Elevation	Right	Plan	3D	Back
GDM-09-SQ-HC-LD					

TRUE MANUFACTURING CO., INC.

2001 East Terra Lane • O'Fallon, Missouri 63366-4434 • (636)240-2400 • Fax (636)272-2408 • Toll Free (800)325-6152 • Intl. Fax# (001)636-272-7546 • www.truemfg.com

EXHIBIT 2
TRADE CONTRACT AMOUNT

Trade Contractor acknowledges that this Trade Contract Agreement is a fixed-sum contract in the amount of [redacted] **and** [redacted] **/100 Dollars (\$** [redacted] **)** (the “**Trade Contract Amount**”) for all Trade Contractor Work. The Trade Contract Amount shall be complete and total compensation for all of Trade Contractor’s fees and expenses including, but not limited to: (i) all wages, benefits and related taxes either direct or subcontracted, (ii) all shop expenses, design fees, general overhead, taxes, telecommunications and any other costs of business or miscellaneous expenses; (iii) all travel expenses and related costs, including but not limited to, airfare, ground transport, accommodations, meals, and incidental travel expenses for Trade Contractor, its staff and associated workers, (iv) all materials whether directly purchased or purchased by subcontractors, (v) insurance coverage at limits required in this Trade Contract, and (vi) all crating, packing, shipping, transport and drayage costs, of whatsoever kind, for the Trade Contractor Work and for any and all tools and materials which Trade Contractor may need to perform its Trade Contract Work.

EXHIBIT 3
EQUITY PLAN

[Trade Contractor to Fill Out]

**TRADE CONTRACT AGREEMENT EQUITY PLAN
TARGETED BUSINESS COMMITMENT AND INFORMATION FORM**

Proposer Company Name: _____

Check ONE of the following:

No Targeted Business participation is committed on this project

The following Targeted Business (MBE & WBE) participation is committed on this project:

Firm Name (Legal business name used for Targeted Business certification)	WBE (Check one)	MBE	How will firm participate? (subcontractor, consortium, joint venture)	Description of work	Estimated dollar value of participation	Estimated percentage of total bid

Total WBE % ___

Total MBE % ___

TARGETED BUSINESSES WHO WERE CONSIDERED BUT WERE NOT SELECTED:

Firm Name	Address	Telephone Number

Certification

On behalf of the proposer identified below, I certify that the information provided in this form is true and correct.

Proposer Name: _____

Signature: _____ Date: _____

Name: _____

Title: _____

EXHIBIT 4
CONSTRUCTION SCHEDULE

The Trade Contractor shall perform its Trade Contractor Work expeditiously and consistent with its contractual obligations to further the orderly progress of the Trade Contractor Work. The Trade Contractor’s Work shall be commenced on the Effective Date, and, subject to authorized adjustments and excusable delays as allowed by the Trade Contract Agreement, Trade Contractor shall achieve Project Milestone Dates and Substantial Completion of its Trade Contractor Work in accordance with this **Exhibit 4**.

Final Completion of the Trade Contractor Work shall be deemed to have occurred only after completion of all the Trade Contractor Work and acceptance of it by the Authority.

The Date of Substantial Completion is described in more detail below:

Substantial Completion

Milestone Dates of the Trade Contractor Work that must be complete in accordance herewith are outlined on the Outline of Construction Schedule below. For purposes of this **Exhibit 4**, “**Scheduled Substantial Completion Date**” shall mean [redacted], 20 [redacted] and “**Guaranteed Completion Date**” shall mean the date set forth across from the corresponding unit or phase of Trade Contractor Work on the Outline of Construction Schedule set forth below.

The following Outline of Construction Schedule highlights critical components of the Project and mandatory Milestone Dates that must be completed, without exception, by the Trade Contractor in order to meet the requirements of the Construction Schedule and Substantial Completion.

OUTLINE OF CONSTRUCTION SCHEDULE

Description of Trade Contractor Work	Start Date	Guaranteed Completion Date	Comments
Design and Install of [redacted]			
** Work to be coordinated with other Subcontractors in each area.			

EXHIBIT 5
BONDS

The Payment and Performance Bond forms that the Trade Contractor is required to provide related to its Trade Contractor Work are attached as **Exhibit 5**.

[See Attached]

TRADE CONTRACTOR LABOR AND MATERIAL PAYMENT BOND

**THIS BOND, ISSUED SIMULTANEOUSLY WITH A PERFORMANCE BOND, RUNS IN FAVOR OF
OBLIGEE AND CLAIMANTS**

Bond Number: _____

KNOW ALL PERSONS BY THESE PRESENTS:

That _____ as Principal, hereinafter
(Here insert full name and address of Trade Contractor)
and, _____ as Surety, hereinafter
(Here insert full name and serving address of Surety)

called Surety, are held and firm bound unto **Minnesota Sports Facilities Authority, 1005 4th Street South, Minneapolis, MN 55415 (the "Authority")**, hereinafter called Obligee, in the amount of \$ _____ (the "Bond Sum") for the payment whereof Trade Contractor and Surety, jointly and severally, bind themselves, their heirs, executors, administrators, successors, and assigns firmly by these presents.

WHEREAS, Trade Contractor has, by written agreement dated as of _____, entered into a Trade Contract with Obligee, Hereinafter called contract, for

(Insert name and location of the project & contact number or general description of the work)

Which contract is by reference made a part hereof.

NOW THEREFORE, Trade Contractor and Surety, jointly and severally, hereby bind themselves, their heirs, executors, administrators, successors and assigns to Obligee to pay for costs for work, skill, tools, machinery, materials, insurance premiums, equipment or supplies or taxes incurred under Minn. Stat. §290.92, Chapter 268 or Chapter 297A (the underline portion hereof referred to as "labor, materials, or equipment") provided to Obligee by Trade Contractor for use in the performance of the Contractor:

THE CONDITION OF THIS BOND is such that, if Trade Contractor shall satisfactorily perform each part of the Contract and any warranties and guaranties required under the Contract, then this Bond shall be null and void; otherwise it shall remain in full force and effect, inclusive of all the prior recitals and the following terms which are herein incorporated.

Whenever Trade Contractor shall be, and is declared by Obligees to be in default under the Contract, Obligees having performed Obligees obligations thereunder, Surety may promptly remedy the default, or shall promptly

1) Complete the Contract in accordance with its terms and conditions; or

2) Obtain a bid or bids for completing the Contract in accordance with its terms and conditions, and upon determination by Surety of the lowest responsible bidder, or, if Obligees elects, upon determination by Obligees and Surety jointly of the lowest responsible bidder, arrange for a contract between such bidder and Obligees, and make available as Work progresses (even though there should be a default or a succession of defaults under the contract or contracts of completion arranged under this paragraph) sufficient funds to pay the cost of completion less the balance of the Contract's Guaranteed Maximum Price; but not exceeding, including other costs and damages for which Surety may be liable hereunder, the Bond Sum. The term "cost of completion" includes, without limitation, responsibilities of Trade Contractor for correction of defective work and completion of the Contract, Obligees legal and design professional costs resulting from Trade Contractor's default, and all damages recoverable under the Contract, including delay damages.

The term "balance of the Contract's Guaranteed Maximum Price, shall mean the total amount payable by Obligees to Trade Contractor under the Contract and any amendments thereto, less the amount paid by Obligees to Trade Contractor.

Any suit or arbitration under this Bond must be instituted before the expiration of the time in which suits or arbitrations may be brought under the Contract by Obligees in the jurisdiction where the Contract is to be performed, such period to be computed from the later of (1) the date of Trade Contractor's default; or (2) the date Surety refuses or fails to perform its obligations under this Bond, or (3) the date of Substantial Completion of the Project as established by the Contract.

Surety shall save Obligees harmless from all costs and charges, up to the amount of the Bond Sum, that may accrue to complete the Work of the Contract following the default of the Trade Contractor. Surety shall not be liable to Obligees in excess of the Bond Sum, as such Bond Sum may be adjusted as provided in the Contract and herein. The amount of this Bond shall be reduced by and to the extent of any payment or payments made in good faith hereunder.

Surety's obligations shall include, up to the Bond Sum, payment for liquidated delay damages owed under the Contract by Trade Contractor to Authority as a result of late completion as provided for in, or governed by, the Contract.

Terms capitalized herein but not defined in this Bond shall have the meaning assigned to them as noted in the Contract.

This Bond shall remain in effect for the longer period of time in which an action may be maintained under the Contract or under Minn. Stat. §574.31, sub 1, as may be amended or succeeded from time to time.

Surety further agrees that in event of any default by the Authority in the performance of the Authority's obligations to the Trade Contractor under the Contract, the Trade Contractor or Surety shall cause written notice of such default, specifying said default in detail, to be given to the Authority. Such notice of default shall be sent by certified or registered U.S. Mail, return receipt requested, first class postage prepaid, to the Authority.

Surety agrees that it is obligated under the bonds to the Authority and to any successor, grantee or assignee of the Authority.

In any claim involving the Obligees, Surety and the Trade Contractor, the Surety shall be bound by and agrees to be a party to the dispute resolution provisions in the Contract, including any arbitration provision therein, and agrees Obligees has the right to join Surety by consolidation or joinder in any other related arbitration with persons bound to arbitrate with the Obligees. The foregoing agreement to arbitrate and consolidate and joinder shall be specifically enforceable under Applicable Laws in any court having jurisdiction thereof.

Signed and acknowledged and sealed this _____ day of _____, 20____.

(Trade Contractor as Principal)

(Surety) (Seal)

By: _____
(Signature)

By: _____
(Signature)

(Print Name)

(Print Name)

(Title)

(Title)

(Trade Contractor signature must be notarized)

(Surety signature must be notarized)
(Bond must be accompanied by a notarized power of attorney
authorizing the above signature on behalf of Surety)

Name and servicing address of agent of Surety:

Telephone: _____

CORPORATE ACKNOWLEDGMENT

State of _____)

) ss

County of _____)

On this _____ day of _____, before me appeared _____, to me personally known, who, being by me duly sworn, did say that he/she is the _____ of _____, a corporation, that the seal affixed to the foregoing instrument is the corporate seal of said corporation, and that said instrument was executed in behalf of said corporation by the authority of its Board of Directors, and that said _____ acknowledged said instrument to be the free act and deed of said corporation.

Notary Public: _____

County: _____

My Commission Expires: _____

SURETY ACKNOWLEDGMENT

State of Minnesota)
) ss
County of Hennepin)

On this _____ day of _____, _____ before me appeared _____,
to me personally known, who being by me sworn, did say that (s)he is the Attorney-in Fact of
_____, a corporation, that
the seal affixed to the foregoing instrument is the corporate seal of said corporation and that
said instrument was executed in behalf of said corporation by authority of its Board of
Directors; and that said _____ acknowledged
said instrument to be the free act and deed of said corporation.

Notary: _____

County: _____

My Commission Expires: _____

TRADE CONTRACTOR LABOR AND MATERIAL PAYMENT BOND

THIS BOND, ISSUED SIMULTANEOUSLY WITH A PERFORMANCE BOND, RUNS IN FAVOR OF OBLIGEE AND CLAIMANTS

Bond Number: _____

KNOW ALL PERSONS BY THESE PRESENTS:

That _____ as Principal, hereinafter
(Here insert full name and address of Trade Contractor)

and, _____ as Surety, hereinafter
(Here insert full name and serving address of Surety)

called Surety, are held and firm bound unto **Minnesota Sports Facilities Authority, 1005 4th Street South,**

Minneapolis, MN 55415 (the "Authority"), hereinafter called Obligee, in the amount of

\$ _____ (the "Bond Sum") for the payment whereof Trade Contractor and Surety, jointly and severally, bind themselves, their heirs, executors, administrators, successors, and assigns firmly by these presents.

WHEREAS, Trade Contractor has, by written agreement dated as of _____, entered into a Trade Contract with Obligee, Hereinafter called contract, for

(Insert name and location of the project & contact number or general description of the work)

Which contract is by reference made a part hereof.

NOW THEREFORE, Trade Contractor and Surety, jointly and severally, hereby bind themselves, their heirs, executors, administrators, successors and assigns to Obligee to pay for costs for work, skill, tools, machinery, materials, insurance premiums, equipment or supplies or taxes incurred under Minn. Stat. §290.92, Chapter 268 or Chapter 297A (the underline portion hereof referred to as "labor, materials, or equipment") provided to Obligee by Trade Contractor for use in the performance of the Contractor:

THE CONDITION OF THIS BOND is such that, if Trade Contractor shall satisfactorily perform each part of the Contract and any warranties and guaranties required under the Contract, then this Bond shall be null and void; otherwise it shall remain in full force and effect, inclusive of all the prior recitals and the following terms which are herein incorporated.

Whenever Trade Contractor shall be, and is declared by Oblige to be in default under the Contract, Oblige having performed Oblige's obligations thereunder, Surety may promptly remedy the default, or shall promptly

1) Complete the Contract in accordance with its terms and conditions; or

2) Obtain a bid or bids for completing the Contract in accordance with its terms and conditions, and upon determination by Surety of the lowest responsible bidder, or, if Oblige elects, upon determination by Oblige and Surety jointly of the lowest responsible bidder, arrange for a contract between such bidder and Oblige, and make available as Work progresses (even though there should be a default or a succession of defaults under the contract or contracts of completion arranged under this paragraph) sufficient funds to pay the cost of completion less the balance of the Contract's Guaranteed Maximum Price; but not exceeding, including other costs and damages for which Surety may be liable hereunder, the Bond Sum. The term "cost of completion" includes, without limitation, responsibilities of Trade Contractor for correction of defective work and completion of the Contract, Oblige's legal and design professional costs resulting from Trade Contractor's default, and all damages recoverable under the Contract, including delay damages.

The term "balance of the Contract's Guaranteed Maximum Price, shall mean the total amount payable by Oblige to Trade Contractor under the Contract and any amendments thereto, less the amount paid by Oblige to Trade Contractor.

Any suit or arbitration under this Bond must be instituted before the expiration of the time in which suits or arbitrations may be brought under the Contract by Oblige in the jurisdiction where the Contract is to be performed, such period to be computed from the later of (1) the date of Trade Contractor's default; or (2) the date Surety refuses or fails to perform its obligations under this Bond, or (3) the date of Substantial Completion of the Project as established by the Contract.

Surety shall save Oblige harmless from all costs and charges, up to the amount of the Bond Sum, that may accrue to complete the Work of the Contract following the default of the Trade Contractor. Surety shall not be liable to Oblige in excess of the Bond Sum, as such Bond Sum may be adjusted as provided in the Contract and herein. The amount of this Bond shall be reduced by and to the extent of any payment or payments made in good faith hereunder.

Surety's obligations shall include, up to the Bond Sum, payment for liquidated delay damages owed under the Contract by Trade Contractor to Authority as a result of late completion as provided for in, or governed by, the Contract.

Terms capitalized herein but not defined in this Bond shall have the meaning assigned to them as noted in the Contract.

This Bond shall remain in effect for the longer period of time in which an action may be maintained under the Contract or under Minn. Stat. §574.31, sub 1, as may be amended or succeeded from time to time.

Surety further agrees that in event of any default by the Authority in the performance of the Authority's obligations to the Trade Contractor under the Contract, the Trade Contractor or Surety shall cause written notice of such default, specifying said default in detail, to be given to the Authority. Such notice of default shall be sent by certified or registered U.S. Mail, return receipt requested, first class postage prepaid, to the Authority.

Surety agrees that it is obligated under the bonds to the Authority and to any successor, grantee or assignee of the Authority.

In any claim involving the Oblige, Surety and the Trade Contractor, the Surety shall be bound by and agrees to be a party to the dispute resolution provisions in the Contract, including any arbitration provision therein, and agrees Oblige has the right to join Surety by consolidation or joinder in any other related arbitration with persons bound to arbitrate with the Oblige. The foregoing agreement to arbitrate and consolidate and joinder shall be specifically enforceable under Applicable Laws in any court having jurisdiction thereof.

Signed and acknowledged and sealed this _____ day of _____, 20____.

(Trade Contractor as Principal)

(Surety)

(Seal)

By: _____
(Signature)

(Print Name)

(Title)

(Trade Contractor signature must be notarized)

By: _____
(Signature)

(Print Name)

(Title)

(Surety signature must be notarized)
(Bond must be accompanied by a notarized power of attorney authorizing the
above signature on behalf of Surety)

<p style="text-align: center;"><u>Name and servicing address of agent of Surety:</u></p> <p>_____</p> <p>_____</p> <p>Telephone: _____</p>
--

CORPORATE ACKNOWLEDGMENT

State of _____)

) ss

County of _____)

On this _____ day of _____, before me appeared _____, to me personally known, who, being by me duly sworn, did say that he/she is the _____ of _____, a corporation, that the seal affixed to the foregoing instrument is the corporate seal of said corporation, and that said instrument was executed in behalf of said corporation by the authority of its Board of Directors, and that said _____ acknowledged said instrument to be the free act and deed of said corporation.

Notary Public: _____

County: _____

My Commission Expires: _____

SURETY ACKNOWLEDGMENT

State of Minnesota)
) ss
County of Hennepin)

On this _____ day of _____, _____ before me appeared _____, to me personally known, who being by me sworn, did say that (s)he is the Attorney-in Fact of

_____, a corporation, that
the seal affixed to the foregoing instrument is the corporate seal of said corporation and that
said instrument was executed in behalf of said corporation by authority of its Board of
Directors; and that said _____ acknowledged
said instrument to be the free act and deed of said corporation.

Notary: _____

County: _____

My Commission Expires: _____

EXHIBIT 6
PROJECT LABOR AGREEMENT

**EXHIBIT 7
WARRANTY**

The following Warranty is included in this Trade Contract Agreement as Exhibit 7:

WARRANTY

Pursuant to the Trade Contract Agreement between the Minnesota Sports Facilities Authority (“**Authority**”) and _____ (“**Trade Contractor**”), Trade Contractor hereby warrants and guarantees that all of the Trade Contractor Work performed under the Trade Contract Agreement will be of new and of good quality, will be free of defects except for those inherent in the quality of the Trade Contractor Work allowed by the Trade Contract Documents, and will conform to the requirements of the Trade Contract Documents (“**Warranty**”). If the Trade Contractor Work does not conform to this Warranty, it shall be considered defective, and Trade Contractor shall remedy at its own expense any such defective Trade Contractor Work (including the costs that the Authority or Architect incur in dealing with or as a result of the defective Trade Contractor Work) so that the Trade Contractor Work conforms to the Trade Contract Documents. The Trade Contractor’s Warranty shall extend for a period of one (1) year after final acceptance by Authority. Where guarantees or warranties are required in the Trade Contract Documents for a period of more than one (1) year, such longer terms shall apply. All Suppliers’ warranties and guarantees, express or implied, respecting any part of the Trade Contractor Work and any materials used therein are hereby assigned by the Trade Contractor to the Authority. This Warranty shall supplement, and not supersede, warranties and guarantees given by Trade Contractor under the terms of the Trade Contract Documents.

TRADE CONTRACTOR:

WITNESS: _____

Title: _____

Date: _____

STATE OF _____

COUNTY OF _____

BEFORE ME, the undersigned authority, on this day, personally appeared _____ known to me to be the person whose name subscribed to the foregoing instrument, and acknowledged to me that he executed the same for the purposes and consideration therein expressed.

GIVEN UNDER MY HAND AND SEAL OF OFFICE this ____ day of _____ 2016.

NOTARY PUBLIC

SEAL

MY TERM EXPIRES

Exhibit B
CONFIDENTIALITY AGREEMENT

(To Be Included Submitted with Indication of Interest and Qualifications)

This Confidentiality Agreement (the "Agreement") made and entered to as of the day of _____ 201_, by and between the Minnesota Sports Facilities Authority ("Authority") and _____ ("Proposer") relating to the design, construction and financing of the new Minnesota Multi-Purpose Stadium (the "Project"). For purposes of this Agreement, Minnesota Vikings Football, LLC are hereinafter referred to as the "Team". The Authority and Team and each of their respective subsidiaries and affiliates are hereafter referred to individually or collectively as "Project Participants".

1. For purposes of this Agreement, "Confidential Information" means "any and all" information accessed, received, obtained or otherwise learned about the Project Participants as a result of the Project, and/or any other information whether or not designated as Confidential Information by the Project Participants. Notwithstanding the above, Confidential Information will not include any information that

- (a) is or becomes public knowledge other than by the Construction Manager's act or omission or
- (b) is or becomes available to without obligation of confidence from a source (other than the Project Participants) having the legal right to disclose that information.

2. Without the prior written consent of the Project Participants, which may be given or withheld in their sole and absolute discretion, the Proposer will (a) not disclose any Confidential Information to any third party nor give any third party access thereto, and (b) only disclose the Confidential Information to those of its employees or agents who need to know such information for purposes of completing the Project and who are bound by confidentiality obligations no less restrictive than this Agreement. For the avoidance of doubt, any disclosure by the Project Participants of work product received from the Proposer shall not be considered a breach of this Agreement.

3. The Proposer will use at least the same degree of care to avoid the publication, disclosure, reproduction or other dissemination of the Confidential Information as employed with respect to its own valuable, proprietary information which it protects from unauthorized publication, disclosure, reproduction or other dissemination and in no event, shall the Construction Manager use less than reasonable care.

4. If the Proposer receives notice that it may be required or ordered to disclose any Confidential Information in connection with legal proceedings or pursuant to a subpoena, order or a requirement or an official request issued by a court of competent jurisdiction or by a judicial, administrative, legislative, regulatory or self-regulating authority or body, the Proposer shall (a) first give written notice of the intended disclosure to the Project Participants as far in advance of disclosure as is practicable and in any case within a reasonable time prior to the time when disclosure is to be made,

(b) consult with the Project Participants on the advisability of taking steps to resist or narrow such request and (c) if disclosure is required or deemed advisable, cooperate with the Project Participants in any attempt made to obtain an order or other reliable assurance that confidential treatment will be accorded to designated portions of the Confidential Information or that the Confidential Information will otherwise be held in the strictest confidence to the fullest extent permitted under the laws, rules or regulations of any other applicable governing body.

5. The Proposer acknowledges that the unauthorized disclosure or use of Confidential Information could cause irreparable harm and significant injury, the precise measure of which maybe difficult to ascertain. Accordingly, the Proposer agrees that the Project Participants will be entitled to specific performance and injunctive or other equitable relief, without bond, as a remedy for any such breach or threatened breach, in addition to all other rights and remedies to which the Project Participants may have. The Proposer will, except to the extent inconsistent with (a) its use in connection with legal proceedings or (b) applicable law, regulations, rules or official requests, at the Authority's election, destroy or return to the Project Participants any tangible copies of the Confidential Information and permanently delete all electronic copies of the Confidential Information in its possession or control, if any, at the earlier of the request of the Project Participants or the completion of the Project and will certify in writing to the Project Participants that it has completed the forgoing.

6. In the event of any litigation between the Project Participants and the Proposer in connection with this Confidentiality Agreement, the unsuccessful party to such litigation will pay to the successful party therein all costs and expenses, including but not limited to actual attorneys' fees incurred

therein by such successful party, which costs, expenses and attorneys' fees shall be included as a part of any judgment rendered in such action in addition to any other relief to which the successful party may be entitled.

7. All references to the Proposer herein also include any of its officers, directors, employees, attorneys, agents, professional advisors and independent contractors and any person, corporation, partnership or other entity which, directly or indirectly, controls, is controlled by, or is under common control with, the undersigned. This Agreement supersedes all previous agreements, written or oral, relating to the above subject matter, and may be modified only by a written instrument duly executed by the parties hereto. All clauses and covenants contained in this Agreement are severable and, in the event, any of them is held to be invalid by any court, this Agreement will be interpreted as if such invalid clauses and covenants were not contained herein. The Proposer represents and warrants that it has the right and authority to enter into and perform this Agreement. This Agreement may not be assigned without the Project Participants' prior written consent (in their sole discretion). This Agreement shall be construed in accordance with the internal laws of the State of Minnesota, USA, without regard to its principles of conflicts of laws. None of the provisions of this Agreement can be waived or modified except expressly in writing by the parties hereto.

Dated and effective this _____ day of _____, 201_

("Authority")

("Proposer")

{SEAL

WITNESS:

(If Proposer is a Corporation, complete below)

By: _____

Title: _____

Attest: _____

Title: _____

EXHIBIT C

NON-COLLUSION AFFIDAVIT

[PROJECT NAME]

[PROJECT NUMBER]

I, _____(Name), being first duly sworn, state that I am the
_____ (office held) of _____ (name of Bidder).

I executed this bid having full authority to do so. I certify that Bidder has not, directly or indirectly, entered into any agreement, participated in any collusion, or otherwise taken any action in restraint of free competitive bidding in connection with the above-named project. No person or persons, natural or corporate, has, have, or will receive, directly or indirectly, any rebate, fee, gift, commission, or other thing of value in consideration for this offer.

Signature

Subscribed and sworn to before me
this ____ day of _____, 20____.

Notary Public

EXHIBIT D



State of Minnesota/Metropolitan Agencies – MDHR Certificate of Compliance

The Request for Proposals or Request for Bids solicitation you responded to may require you to have or to obtain a Certificate of Compliance from the Minnesota Department of Human Rights (MDHR). Please fill out and submit this form with supporting documentation. The bid-award agency will not review your proposal or bid until MDHR and the bid-award agency review this form and/or supporting documentation.

Option A – We have employed more than 40 full-time employees on any single day in any state during the previous 12 months. Please check the applicable box below.

We have a MDHR Certificate of Compliance. Attached is the Certificate.

We don't have a MDHR Certificate of Compliance. Attached is our application for a MDHR Certificate of Compliance.

Option B – We have an affirmative action plan approved by the Federal Government but no MDHR Certificate of Compliance. Please check the box below.

Attached is a copy of the affirmative action plan approved by the Federal government in the last 12 months, the Federal government's approval letter, and our application for a MDHR Certificate of Compliance.

Option C – We are exempt because we employed fewer than 40 full-time employees on any single day in any state during the previous 12 months. Please check the box below.

We are exempt. Attached is a list of all of our employees and their state of employment during the past 12 months.

Option D – The current bid is exempt. The bid award agency doesn't expect the goods or services provided will exceed \$100,000.

The bid proposal is exempt. The bid project number is: _____.

Signature

In signing this document, you certify that the information is accurate and that you are authorized to sign on behalf of the company.

Name of Company	Authorized Signature
Date	Printed Name
Phone Number	Title

EXHIBIT E

Construction Documents

EXHIBIT F

**NEW MINNESOTA MULTI PURPOSE STADIUM
ACKNOWLEDGEMENT AND ATTESTATION FORM
(To Be Submitted with Proposal)**

In submitting a Proposal, the undersigned has certified that the Proposer has reviewed the Request for _____ Proposal ("RFP") dated _____ and is familiar with the terms and conditions therein and accepts and waives any protest of the terms and conditions imposed under the RFP and all documents identified therein.

The Proposer understands the Authority and Team reserve the right to reject any or all proposals in accordance with its best interest. The Proposer submitting a response does so at its own expense. I hereby certify that the foregoing is true and correct.

Proposer's Name: _____ (Company)
Name: _____ (Officer of Company)
Title: _____
Date: _____

Witness: _____
Name: _____
Date: _____

Note: Use full corporate name and attach corporate seal, if any, here. {SEAL}