

## REQUEST FOR PROPOSALS

# Food Services Equipment Procurement

## FOR CAPITAL IMPROVEMENT TO U.S. BANK STADIUM IN MINNEAPOLIS, MINNESOTA

April 13, 2018

### A. Project Background and Objectives

In 2012, the State of Minnesota enacted 2012 Minnesota Laws, Chapter 299 (the “Act”), to establish the Minnesota Sports Facilities Authority (“Authority”) and to provide for the construction, financing, and long-term use of a new stadium now known as U.S. Bank Stadium (the “Stadium”) and related stadium infrastructure (the “Stadium Infrastructure”) as a venue for professional football and a broad range of other civic, community, athletic, educational, cultural and commercial activities.

As set forth in the Act, the Authority may make capital improvements to design, development and construction of the Stadium and the Stadium Infrastructure, and the certain capital improvements that that Authority is soliciting in this Request for Proposals (“RFP”) shall be referred to in this RFP as the “Project”. To that end, the Authority has prepared this RFP for the Food Services Equipment. Those who respond to this RFQ shall be referred to as “Proposers”.

The Project is located at the Stadium and other additional adjacent land that has been acquired by the Authority in Minneapolis, Minnesota. The Specification Documents identifying and indicating the scope of the Project are also incorporated within this RFP as **Exhibit 1**. The Specifications Documents meet the standards required for a National Football League (“NFL”) franchise, as well as additional standards established by the Authority. The Project must be completed by July 16, 2018 (the “Required Completion Date”).

B. Scope of Services: The successful Proposer to the RFP will be engaged to provide sourcing, procurement, installation, and commissioning of foodservice equipment as listed in this RFP (as further described in the RFP and any addenda that will be issued to this RFP) including, without limitation:

- Acquire all permits and conform to locate and State codes.
- Design, provide, install, hook up, coordinate, test, and inspect all items required to complete the work associated with the Project. This includes receiving, inspecting, uncrating, and removal/disposal of packing material. Clean-up of all work areas is required as part of this scope

- All necessary tools, equipment and components (cords, connections, fasteners, etc.) as needed to provide a turnkey installation and delivery of the Project.
- Provide testing and commissioning of system(s).
- All premium (overtime) hours required to meet the Project schedule and scope, not including time added due to Owner revisions/additions.
- One-year on-site warranty to repair or replace the work and services constituting the project.

C. Intent and Process of the Request for Proposals

This RFP is focused on the selection of Proposer that will provide the best value to the Authority in the sourcing, procurement, installation, and commissioning of the foodservice equipment.

Proposers should have significant experience in foodservice equipment projects similar to the Project that is the subject of this RFP. It is the desire of the Authority to consider as part of its selection criteria the commitment of the Proposer to exert good faith efforts to comply with the plan of the Authority to ensure equitable opportunities for Minority Owned Business Enterprises (“MBE”) and Women Owned Business Enterprises (“WBE”) to participate in the Project. The successful Proposer or Proposers must also demonstrate the ability to exert good faith efforts to comply with workforce goals and targeted zip code hiring goals, and work with organizations to develop effective MBE, WBE and workforce recruitment efforts during the sourcing, procurement, installation, and commissioning of the foodservice equipment. Each Proposer should provide a plan describing how they will encourage the participation and utilization of appropriate workforce, MBEs and WBEs in the Proposers’ performance of their services. MBEs and WBEs that are interested in acting as the Proposers for the Project are encouraged to respond to the RFP.

D. Requested Qualifications

The Authority reserves the right and discretion to determine the qualifications and responsibility of the Proposers to perform the work and services that are the subject of the RFP. It is the request and intent of the Authority that Proposers responding to the RFP have the following qualifications.

- Significant experience in projects similar to the project outlined in this RFP.
- Experience in the design, coordination, supply, installation, and testing of similar foodservices equipment.
- In-house capacity to produce necessary installation, testing and schedule documentation, which does not preclude any Proposer from also identifying potential sub-consultants that could assist in producing such estimates and schedules.

- Performance and payment bond bonding capacity or ability to obtain bonding capacity to the full amount of the selected scope of the Project System contained within the submitted Proposal.

E. RFP Timeline

Advertise and issue Request for Proposals	April 24, 2018
Pre-proposal Site Visits	
Written Questions Due	May 4, 2018 by 5PM
Proposals Due	May 11, 2018 by 5PM
Interviews of Shortlisted Proposers	May 21, 2018
Final Negotiations	May 28, 2018
Selection of Provider	June 4, 2018
Project Completion	July 16, 2018

By submitting a Proposal, the Proposer affirms that this timeline must and can be met to avoid the potential for significant harm to the progress of the Project and to the interests of the Authority and public.

F.1 Proposer Executive Summary

The following items shall be included in a Proposal executive summary:

- Proposer’s name and address of office that would have central responsibility for the work. Identify the business form of Proposer and list the principal shareholders or other business owners. If the proposed form of entity is a joint venture, please identify each joint venture participant and their respective percentage of participation. Provide a summary describing why the Proposer is the most qualified to be the Provider for the Project.
- Provide copies of Proposer’s certificates of insurance showing Proposer’s current total limits of liability for commercial general liability, worker’s compensation, employer's liability, business automobile liability, and professional liability.
- Provide representative list of similar projects managed by Proposer during that last 5 years or that are currently under construction or management. Include:
  - Project name.
  - Project location.
  - Key contact or reference from project Owner including name, title, email, and telephone number.
- Submit your proposals on the exhibits listed below to the draft Trade Contractor Agreement, which Proposer should anticipate will become exhibits to the final,

executed Trade Contract should the Proposal be accepted. In addition to being attached to the Trade Contractor Agreement, these exhibits are also directly attached to this Request for Proposals in order to bring them to Proposers' direct attention. In their Proposals, Proposers' should label these proposed exhibits using the exhibit numbers set forth below.

- Exhibit 1 – Description of Trade Contractor Work. Proposer should provide its proposed form of Exhibit 1 and should indicate any proposed changes to the terms provided by the Authority by including both it should include both a red-lined and a clean version of its proposed version in its Proposal.
- Exhibit 2 – Trade Contract Amount. In addition to providing the itemized pricing information requested below in Section F.2, Proposer should provide its proposed version of Exhibit 2.
- Exhibit 3 – Targeted Business Commitment and Information Form.
- Exhibit 4 – Targeted Business Information Form.
- Exhibit 5 – TCA Equity Plan Progress Report.
- Exhibit 6 – Installation Schedule. Proposer should provide its proposed schedule.
- 7 – Bonds. The Authority has provided its form for the required payment and performance bonds. As part of providing information regarding its bonding capacity, Proposer should indicate whether it has any proposed changes to the Authority's forms. If Proposer has any proposed revisions, it should include both a red-lined and a clean version of its proposed version in its Proposal.
- Exhibit 8 – Warranty. The Authority has provided its form for the required warranty. If Proposer has any proposed revisions, it should include both red-lined and clean versions of its proposed version in its Proposal.
- If Proposer has any other proposed revisions to the Trade Contractor Agreement (Exhibit A), it should include both red-lined and clean versions of its proposed version in its Proposal.

## F.2 Submittal Requirements: Evaluation of Proposals

Proposers shall include the following items in their Proposal. As described below, the Authority will score Proposals on a point system, with some criteria being graded on a pass-fail basis. Proposers who fail any criterion may have their Proposal rejected. A total of 300 points will be available as follows:

Project Proposal: 100 points

Technical Specifications: 100 points

Commercial Terms: 100 points

Equitable Contracting and Hiring: Pass/Fail

The Proposals receiving the highest three scores, as determined by the Authority in its sole discretion, will then be short-listed and selected to enter into final discussions and negotiations with the Authority, as a result of which the Authority will select in its discretion the Proposer whose final Proposal is most advantageous and the best value to the Authority as permitted by the Act.

### **Project Proposal – 100 Points**

1. Similar Project Experience. Describe Proposer's experience with similar projects.
2. Project Personnel. Provide names and resumes of key personnel who would be directly responsible for the work. Provide key contact telephone, fax, and email addresses.
3. Preliminary Performance Schedule. Provide Proposer's preliminary critical path schedule with milestones identified for critical items of ordering, installation, testing, and completion of the scope of work required by this RFP by the required deadline.

### **Technical Specifications – 100 Points**

4. Technical Specifications. Proposals shall include equipment and materials equal to those listed in spec sheets provided.

### **Commercial Terms – 100 Points**

1. Price. Provide itemized pricing on all necessary design, coordination, supply, installation, and testing elements necessary to deliver a complete Project and all scope of work items required by this RFP, including without limitation:
  - All material and equipment;
  - All design or design assist services;
  - All construction and installation;
  - All training and testing;
  - Warranty for onsite hardware maintenance for one year;
  - Detailed cost information for ongoing fixed and variable costs;

- Estimate of all other project expenses including travel, shipping, and sales tax (if any); and,
- Proposed form of Exhibit 2.

1. Warranties and Maintenance. A one-year warranty will be required covering the services and work performed for the Project. Provide copies of the proposed warranties and describe the warranty terms, durations, limitations, etc. Describe any service and maintenance programs, including copies of all proposed or required service and maintenance contracts and fees. Any proposed revisions to Exhibit 8 shall be considered in evaluating this factor.

2. Agreement to or Requested Revisions to Trade Contract Agreement The extent to which revisions are requested to the Authority's proposed contract in this RFP will be given point deductions in the sole discretion of the Authority. Any proposed revisions to Exhibit 1 shall be considered in evaluating this factor.

#### **Equitable Contracting and Hiring – Pass/Fail**

1. Hiring and MBE/WBE Utilization. Describe Proposer's practices and history of hiring women and minorities. Also describe Proposer's specific plan to reach targeted goals for MBE and WBE construction participation on this project, and Proposer's strategies for employing women and members of minority communities to comply with the Authority's Equity Plan. Exhibits 3 to 5 shall be considered in evaluating this factor.

According to the Act, there shall be no disclosure of any information derived from Proposals submitted by competing Proposers and the content of all Proposals is nonpublic data under Chapter 13 of Minnesota Statutes until such time as a notice to award a contract is given by the Authority.

The Authority may change its scoring of Proposals as a result of negotiations with Proposers.

A Proposer's response may also contain any narrative, charts, tables, diagrams, or other materials in addition to those called for herein, to the extent such additions are useful for clarity or completeness of the response. Attachments should clearly indicate on each the page the paragraph in the RFP to which they pertain.

The RFP, responses to it, and any subsequent negotiations and discussions shall in no way be deemed to create a binding contract or expectation of an agreement between the Proposer and the Authority.

Each Proposer submitting a Proposal in response to this RFP acknowledges and agrees that the preparation of all materials for submittal to the Authority and all presentation, related costs, and travel expenses are at Proposer's sole expense and that the Authority shall not, under any circumstances, be responsible for any cost or expense incurred by the Proposers, except the payment of the stipend that will be given to those short listed Proposers who properly submit in

good faith the preliminary construction estimate and otherwise complete the RFP process. The Authority shall be allowed to keep any and all materials supplied by the Proposers in response to the RFP.

The Authority reserves the right to accept or reject any or all Proposals, to amend or alter the selection process in any way by addendum, to postpone the selection process for its own convenience at any time, and to waive any non-material defects in proposals submitted. Proposals are required to remain open and subject to acceptance until an award is finalized, or a minimum of (90) days following the date of submission of Proposals. The Authority also reserves the right to accept or reject any individual sub-consultants that the successful Proposer proposes to use.

A. Payment and Performance Bonds

By Minnesota statutes and the Act, payment and performance bonds will be required from the successful Proposer in the amount of 100% of the cost of Proposal.

Proposals are due by 5:00 pm. CST, April 30, 2018. One electronic copy and 4 bound copies of each Proposal should be enclosed in a sealed envelope addressed to:

Minnesota Sports Facilities Authority  
Attention: James Farstad  
1005 4<sup>th</sup> Street South  
Minneapolis, Minnesota 55415

With an electronic copy sent via email to John Fitzgibbon at [Fitzgibbon-john@aramark.com](mailto:Fitzgibbon-john@aramark.com)

One electronic copy and 4 bound copies should also be sent and addressed to:

B. Questions or Inquiries

All questions must be submitted via email no later than 5:00 pm. CST, April 23, 2018 to:

Aramark-U.S. Bank Stadium  
John Fitzgibbon – [Fitzgibbon-john@aramark.com](mailto:Fitzgibbon-john@aramark.com)  
and  
MSFA-U.S. Bank Stadium  
James Farstad – [james.farstad@msfa.com](mailto:james.farstad@msfa.com)

C. Minnesota Government Data Practices

All Proposals are eventually subject to the Minnesota Government Data Practices Act, Minn. Statutes, Chapter 13, but the Act prohibits disclosure of any information derived from Proposals submitted by competing Proposers, and the content of all Proposals is nonpublic data under Chapter

13 until such time as notice to award a contract to the successful Proposer is given by the Authority. Proposers shall note with their Proposal any data in their Proposal that they consider proprietary information or otherwise private and confidential.

D. Other Exhibits to the RFP

Exhibit A	Trade Contract Agreement
Exhibit B	Confidentiality Agreement – Must be filled out by Proposer
Exhibit C	Non-Collusion Statement – Must be filled out by Proposer
Exhibit D	Minnesota Department Affirmative Action Data Page-- Must be filled out by Proposer
Exhibit E	Construction Documents – Must be filled out by Proposer
Exhibit F	Acknowledgement and Attestation Form – Must be filled out by Proposer

**The following exhibits are associated with the Trade Contract Agreement, and will be required for contract approval:**

Trade Contract Agreement and Exhibits to Agreement – Proposer must fill out **ALL** of the following forms:

Exhibit 1	Description of Trade Contract Work
Exhibit 2	Trade Contract Amount
Exhibit 3	Targeted Business Commitment and Information Form
Exhibit 4	Targeted Business Information Form
Exhibit 5	TCA Equity Plan Progress Report
Exhibit 6	Construction Schedule
Exhibit 7	Bonds
Exhibit 8	Warranty
Exhibit 9	Insurance Certificates



**EXHIBIT A**  
**Trade Contract Agreement**

[See Next Page]

---

**TRADE CONTRACT AGREEMENT BETWEEN THE MINNESOTA  
SPORTS FACILITIES AUTHORITY  
AND THE TRADE CONTRACTOR**

---

**TRADE CONTRACT AGREEMENT**

THIS TRADE CONTRACT AGREEMENT (“Trade Contract Agreement”) is made as of the [ ] day of [ ] in the year of [ ] (“Effective Date”).

**BY AND BETWEEN**

The **AUTHORITY:**

**MINNESOTA SPORTS FACILITIES AUTHORITY**  
1005 4<sup>th</sup> Street South  
Minneapolis, MN 55415

and the

**TRADE CONTRACTOR:**

For:

For the following **PROJECT:** Capital Improvement to the Stadium and Stadium Infrastructure for U.S. Bank Stadium for the following work:

---

---

---

---

---

---

---

---

## 1. General Provisions

**1.1 Definitions.** The definitions set forth in **Attachment A** shall apply in this Trade Contract Agreement.

**1.2 Correlation and Intent.** It is the intent of the Trade Contractor and Authority that the Trade Contract Documents include all items necessary for proper design, construction, execution and completion of the Trade Contractor Work. The Trade Contract Documents are complementary, and what is required by any one shall be binding as if required by all. Work not covered in the Trade Contract Documents, but reasonably inferable from the Trade Contract Documents, will be included as part of the Trade Contractor Work. The Trade Contractor covenants with the Authority to furnish the Trade Contractor's best skill and judgment and to cooperate with the Project Participants in furthering the interests of the Authority and to perform the Trade Contractor Work in an expeditious manner. The Trade Contractor represents that the Trade Contractor has visited the Project Site, become familiar with the local and specific conditions under which the Trade Contractor Work is to be performed and correlated personal observations with requirements of the Trade Contract Documents and Agreement. Prior to execution of its Trade Contractor Work, the Trade Contractor and each Subcontractor shall evaluate and satisfy themselves as to the conditions and limitations under which the Trade Contractor Work is to be performed, including (a) the location and layout of the Project Site, (b) prevailing climatic conditions, (c) anticipated labor supply and costs, (d) market conditions that will impact the Trade Contract Amount, (e) the requirement that the Trade Contractor has completed a thorough and comprehensive review of the Trade Contract Documents and understands and recognizes the complete scope of the Trade Contractor Work required by the Trade Contract Agreement, (f) existing conditions that will impact the Trade Contractor Work, and (g) availability and cost of materials, tools, and equipment. The Authority shall not be required to make any adjustment in the amount due, if any, under the Trade Contract Agreement to the Trade Contractor or the time required for Trade Contractor's performance of the Trade Contractor Work under the Trade Contract Agreement. In the event of inconsistencies within or between parts of the Trade Contract Documents, or between the Trade Contract Documents and Applicable Laws and specified NFL Rules and Regulations, the Trade Contractor shall (x) provide the better quality or greater quantity of the Trade Contractor Work or (y) comply with the more stringent requirement, either or both in accordance with the Authority's reasonable interpretation.

**1.3 Project Site.** Before ordering any materials or doing any Trade Contractor Work, the Trade Contractor shall verify all existing conditions and measurements at the Project Site and shall be responsible for the correctness of such measurements. Any difference that may be found shall be submitted to the Authority for interpretation before proceeding with the Trade Contractor Work. Any errors due to the Trade Contractor's failure to so verify all such dimensions or locations shall be

promptly rectified by the Trade Contractor without any additional cost to the Authority.

## **2. Trade Contractor Work**

**2.1 Scope of Work.** The Trade Contractor shall provide all services, work, labor, materials, equipment and other necessary payments as are required to complete the Trade Contractor Work as set forth in the Trade Contract Documents and as set forth on **Exhibit 1**. The Trade Contractor Work is intended to be inclusive of all design, construction, services, work, labor, materials, engineering, Testing, tools, supplies, facilities, management, supervision, permits, licenses, taxes, inspections and equipment required by, or reasonably inferable from, the Trade Contract Documents necessary to complete the Trade Contractor Work pursuant to the Construction Schedule for the Trade Contract Amount.

**2.2 Responsibilities.** The Trade Contractor Work consists of those services performed by the Trade Contractor, its employees, Subcontractors, Suppliers, and Sub-subcontractors of all tiers. The Trade Contractor is solely and strictly responsible for the performance of all Persons performing the Trade Contractor Work, including Subcontractors, Suppliers, and Sub-subcontractors of all tiers. It is the responsibility of the Trade Contractor to ensure that all Subcontractors and Suppliers, including Sub-subcontractors at every tier, that is performing any portion of the Trade Contractor Work are familiar with all the terms and conditions of this Trade Contract Agreement and the Trade Contract Documents and that their performance is in accordance therewith.

**2.3 Cooperation.** The Trade Contractor shall cooperate in all respects with other Persons associated with the Authority, which may include the Architect, lenders, any lender's inspecting architect or representative, insurers, the Team, sponsors, the National Football League, television broadcast networks, radio broadcasters, cellular/distributed antennae providers, and Governmental Authorities.

**2.4 Representation and Warranty.** The Trade Contractor warrants and represents the following: (a) the Trade Contract Amount is just and reasonable compensation for all the Trade Contractor Work; (b) said Trade Contract Amount is sufficient to address all foreseen and unforeseen conditions that will impact the Trade Contractor Work and ability to complete the Trade Contractor Work in accordance with the Trade Contract Amount and Contract Time; (c) the Contract Time is adequate for the performance of the Trade Contractor Work; and (d) the Trade Contractor has a complete understanding of the scope of the Trade Contractor Work and has been provided adequate time to establish the Trade Contract Amount in sufficient detail to support the Trade Contract Amount.

**2.5 Discipline.** The Trade Contractor shall enforce strict discipline and good order among the Trade Contractor's employees and other Persons carrying out the Trade Contractor Work. The Trade Contractor shall not permit employment of unfit Persons not skilled in tasks assigned to them.

**2.6 Labor Harmony.** The Trade Contractor shall only employ labor in connection with the Trade Contractor Work capable of working harmoniously with all trades, crafts, and any other Persons associated with the Project. The Trade Contractor shall also use its best efforts to minimize the likelihood of any strike, work stoppage, or other labor disturbance.

**2.6.1** In case the progress of the Trade Contractor Work is affected by any undue delay in furnishing or installing any items or materials or equipment required under the Trade Contract Documents because of a conflict involving any labor agreement or regulation, the Authority may require that other material or equipment of equal kind and quality be provided pursuant to a Contract Revision, Change Order, or Construction Change Directive to maintain the Trade Contractor's Construction Schedule at no additional cost to the Authority.

**2.7 [RESERVED].**

**2.8 Substitutions and Alternates.** If, after execution of the Agreement and prior to submittal of applicable Shop Drawings to the Architect and Authority, the Trade Contractor desires to submit an Alternate product in lieu of what has been specified or shown in the Trade Contract Documents, the Trade Contractor may proceed only after receiving written approval from the Authority. All prototypes that have been approved must be installed in their required locations by Trade Contractor, unless an Alternate product has been approved in writing by the Authority.

**2.9 Permits.** The Trade Contractor shall secure, pay for, and, as soon as practicable, furnish the Authority with copies or certificates of all permits and fees, licenses and inspections necessary for the proper execution and completion of the Trade Contractor Work. The Trade Contractor shall procure all certificates of inspection, occupancy, permits, and licenses, pay all customary charges and fees, and give all notices necessary and incidental to the lawful prosecution of the Trade Contractor Work. The Trade Contractor shall deliver certificates of inspection, use, and occupancy to the Authority upon completion of the Trade Contractor Work in sufficient time for occupancy or use of the Trade Contractor Work in accordance with the Construction Schedule. The costs of such procurement, payment, and delivery are included within the Trade Contract Amount in the Agreement.

**2.9.1** If the Trade Contractor performs any Trade Contractor Work knowing it to be contrary to Applicable Laws without such notice to the Authority and Architect, the Trade Contractor shall assume full responsibility for such Trade Contractor Work and shall bear any and all costs attributable to correct it and all damages resulting therefrom.

**2.10 [RESERVED]**

**2.11 Trade Contractor's Construction Schedule.** The Trade Contractor shall prepare in consultation with the Authority, Team, Construction Manager and Architect, and submit for the Authority's and Construction Manager's review and approval, a Construction Schedule. The Construction Schedule shall not exceed time limits current under the Trade Contract Documents, shall be updated and revised at appropriate intervals as required by the conditions of the Trade Contractor Work and Project, shall be related to the entire Project to the extent required by the Trade Contract Documents, shall provide for expeditious and practicable execution of the Trade Contractor Work, and the Critical Path and Construction Milestone Dates shall not be modified or extended without the prior written approval of the Authority or as provided in the Trade Contract Documents in each instance. The Trade Contractor acknowledges and agrees it must coordinate its Trade Contractor Work and that in no event shall the Authority be responsible for any costs incurred by Trade Contractor due to its responsibility to coordinate its Trade Contractor Work and not interfere with other Trade Contractors and vendors. In the event the Authority determines that the performance of the Trade Contractor Work has not progressed or reached the level of completion required by **Exhibit 6** of this Trade Contract Agreement or the Construction Schedule, the Authority shall have the right, but not the obligation, to order the Trade Contractor to take corrective measures necessary to expedite the progress of construction, including (a) working additional shifts or overtime, (b) supplying additional manpower, equipment, and facilities, and (c) other similar measures (hereinafter referred to collectively as "**Extraordinary Measures**"). Such Extraordinary Measures shall continue until the progress of the Trade Contractor Work complies in the Authority's reasonable judgment with the stage of completion required by the approved Construction Schedule. The Authority's right to require Extraordinary Measures is solely for the purpose of ensuring the Trade Contractor's compliance with the Construction Schedule or as required by this **Paragraph 2.11**. To the extent that the need for Extraordinary Measures is the responsibility or fault of the Trade Contractor, the Trade Contractor shall not be entitled to an adjustment in the Trade Contract Amount or Contract Time in connection with Extraordinary Measures pursuant to this **Paragraph 2.11**. Float in the Construction Schedule shall be utilized for the benefit of the Project.

**2.12 Shop Drawings, Product Notes and Samples.** The Trade Contractor shall perform no portion of the Trade Contractor Work until the associated Shop Drawings, Product Data, Samples, or similar Submittals related to that Trade Contractor Work has been reviewed and approved by the Authority (or if designated by the Authority, by its designee). Such Trade Contractor Work shall be in accordance with approved Submittals.

**2.12.1** The Trade Contractor shall not be relieved of responsibility for deviations from requirements of the Trade Contract Agreement by the Authority's (or if designated by the Authority, its designee's) approval of Shop Drawings, Product Data, Samples, or similar Submittals, unless the Trade Contractor has specifically informed the Authority (or if designated by the Authority, its designee) in writing of the existence and nature of such deviation at the time of submittal and the Authority

(or if designated by the Authority, its designee) has given written approval to the specific deviation. The Trade Contractor shall not be relieved of responsibility for errors or omissions in Shop Drawings, Project Data, Samples, or similar Submittals by the Authority's (or if designated by the Authority, its designee's) approval thereof.

**2.12.2** The Trade Contractor represents and warrants that all Shop Drawings shall be prepared by Persons and entities possessing expertise and experience in the trade for which the Shop Drawing is prepared and, if required by the Trade Contract Documents or Applicable Laws, by a licensed design professional.

**2.13 Cutting and Patching.** The Trade Contractor shall be responsible for cutting, fitting, or patching required to complete the Trade Contractor Work or to make the Trade Contractor Work fit together properly. The Trade Contractor shall be responsible for cutting, patching, repairing, and cleaning of any and all Project walls, floors and ceilings that it may damage during construction.

**2.13.1** The Trade Contractor shall not damage or endanger a portion of the Trade Contractor Work, the fully or partially completed work of a separate Trade Contractor, Vendor, or any other Project Participant by cutting, patching, or otherwise altering such construction, or by excavation, except with written consent of the Authority and the Construction Manager, the other Trade Contractor or Vendor; such consent shall not be unreasonably withheld. The Trade Contractor shall not unreasonably withhold from the Authority, Construction Manager, Trade Contractor, or Vendor the Trade Contractor's consent to cutting or otherwise altering the Trade Contractor Work.

**2.13.2** Altering or cutting of structural members will not be allowed without written approval by the Architect or Construction Manager. The Trade Contractor shall in all cases exercise extreme care in cutting operations and perform such operations under adequate supervision by competent mechanics skilled in the applicable trade. Openings shall be neatly cut and shall be kept as small as possible to avoid unnecessary damage. Careless, avoidable cutting or damage is not permitted and the Trade Contractor will be held responsible for such avoidable damage.

**2.14 Cleaning Up.** The Trade Contractor shall keep the premises of the Trade Contractor Work and all surrounding areas to the Project Site free from (a) accumulation of waste materials, debris, or rubbish; (b) the Trade Contractor's tools, construction equipment, machinery; and (c) surplus materials, and any excess mud, gravel, or earth caused by operations under the Trade Contract Agreement. At completion of the Trade Contractor Work, the Trade Contractor shall remove from and about the Project all waste materials, debris, rubbish, the Trade Contractor's tools, construction equipment, machinery, surplus materials, and any excess mud, gravel, or earth from and around the Project and the surrounding rights-of-way. If the Trade Contractor fails to cleanup as required, the Authority may, but shall not be

obligated to, perform the Trade Contractor's cleanup and charge the cost thereof to Trade Contractor.

**2.15 Access to Trade Contractor Work.** The Trade Contractor shall provide the Authority, Team, their respective agents and representatives, and Architect access to the Trade Contractor Work in preparation and progress wherever located.

**2.16 Means and Methods.** In no event shall the Authority or Indemnitees have any responsibility or liability for design or construction means, methods, techniques, sequences, or procedures, or for safety precautions and programs in connection with the Trade Contractor Work, notwithstanding any of the rights and authority granted the Authority and Indemnitees in the Trade Contract Agreement.

### **3. Design Services.**

**3.1 Performance and Coordination.** The Design Services provided by the Trade Contractor, or through a design professional Consultant that Trade Contractor retains to fulfill its obligations under the Trade Contract Agreement, shall be performed in strict accordance with all provisions of the Act. Trade Contractor shall coordinate and integrate the Design Services with the Architect, Construction Manager and other Trade Contractors and Vendors to allow the Construction Manager, Vendors, and Trade Contractors to complete their work.

**3.2 Standard of Care.** The Design Services provided by Trade Contractor for the design and construction of its Trade Contractor Work shall be provided pursuant to the Standard of Care applicable to similarly situated design professionals performing similar professional design services.

### **4. Contract Time**

**4.1 Time.** The Trade Contractor shall perform the Trade Contractor Work expeditiously, efficiently, and safely in accordance with the Construction Schedule. The Trade Contractor shall commence its Trade Contractor Work promptly. Trade Contractor shall achieve Substantial Completion of the Trade Contractor Work within the time frames specifically described in **Exhibit 6**. The Trade Contractor shall be considered to have achieved Final Completion only after the Trade Contractor completes all of the Trade Contractor Work and the Trade Contractor Work is accepted by the Authority.

**4.2 "Substantial Completion" or "Substantially Complete"** shall mean the date or dates listed in **Exhibit 6** and that the Trade Contractor Work (or separable units or phases as may be agreed to by the Authority) is essentially and satisfactorily complete in accordance with the Trade Contract Documents, such that the Trade Contractor Work is fully commissioned, fully operational, received all required certifications and approvals pursuant to Applicable Law, and will permit beneficial use by the Authority. A minor amount of Trade Contractor Work, as determined by and at the discretion of Authority, such as installation of minor accessories or items, a minor amount of



painting, minor replacement of defective work, minor adjustment of controls or systems, or completion or correction of minor exterior work that cannot be completed due to weather conditions, will not delay determination of Substantial Completion. For purposes of Substantial Completion, specified areas of the entire Trade Contractor Work as may be chosen by the Authority may be individually judged as Substantially Complete. In no event shall Substantial Completion be deemed to have occurred until any certificates or licenses required from Suppliers for use of the Trade Contractor Work have been delivered to the Authority.

**4.3 Punchlist.** When the Trade Contractor considers that the Trade Contractor Work, or a portion thereof which the Authority agrees to accept separately, is Substantially Complete, the Trade Contractor shall prepare and submit to the Authority a comprehensive Punchlist of items to be completed or corrected. The Trade Contractor shall proceed promptly to complete and correct items on the Punchlist. Failure to include an item on the Punchlist does not alter the responsibility of the Trade Contractor to complete all Trade Contractor Work in accordance with the Trade Contract Documents. The Authority reserves the right to add to the Punchlist within thirty (30) Days after receipt of an acceptable Punchlist from the Trade Contractor. Upon receipt of the Trade Contractor's Punchlist, the Authority will make an inspection to determine whether the Trade Contractor Work or designated portion thereof is Substantially Complete. If the inspection discloses any item, whether or not included on the Trade Contractor's Punchlist, which is not in accordance with the requirements of the Trade Contract Documents, the Trade Contractor shall, before issuance of the Certificate of Substantial Completion, complete or correct such item upon notification by the Authority. The Trade Contractor shall then submit a request for another inspection by the Authority to determine Substantial Completion. When the Trade Contractor Work or designated portion thereof is Substantially Complete, the Authority will prepare a Certificate of Substantial Completion for execution by the parties.

**4.4 Final Completion.** Within sixty (60) Days after Substantial Completion, the Trade Contractor shall achieve Final Completion of all Trade Contractor Work. The date of Final Completion shall establish the start of responsibility under the Agreement for security, maintenance, heat, utilities, damage to the Trade Contractor Work, and insurance. Warranties required by the Trade Contract Documents shall commence on the date of Final Completion of the Trade Contractor Work or designated portion thereof. The Certificate of Final Completion shall be submitted to the Authority and the Trade Contractor for their written acceptance of responsibilities assigned to them in such Certificate. Final Completion of the Trade Contractor Work shall not occur until the Trade Contractor submits to the Authority (a) an affidavit that payrolls, bills for materials and equipment, and other indebtedness connected with the Trade Contractor Work for which the Authority or the Authority's property might be responsible or encumbered have been paid or otherwise satisfied, (b) a certificate evidencing that insurance required by the Trade Contract Documents to remain in force after Final Completion is currently in effect and that Trade Contractor will give the Authority and Team not be canceled or allowed to expire until at least thirty (30)

Days' prior written notice to the Authority and Team before they are allowed to expire or be cancelled except in the event of non-payment of premium, in which case seven (7) Days' prior notice will be provided, (c) a written statement that the Trade Contractor knows of no substantial reason that the insurance will not be renewable to cover the period required by the Trade Contract Documents or the Agreement, (d) consent of surety, if any, to final completion, and (e) if required by the Authority, other data establishing payment or satisfaction of obligations, such as receipts, releases and waivers of liens, Claims, security interests or encumbrances arising out of the Trade Contract Documents, to the extent and in such forms as may be designated by the Authority. If a Lien or Claim for payment relating to the Trade Contractor Work remains unsatisfied after Final Completion, the Trade Contractor shall pay to the Authority all money that the Authority may be compelled to pay in discharging such Lien or Claim, including all costs and reasonable attorneys' fees.

**4.5 Force Majeure.** If the Trade Contractor is delayed in the progress of the Trade Contractor Work by events of Force Majeure, fire or other property damage not caused by the Trade Contractor or a Subcontractor, Supplier, Sub-subcontractor of any tier, or other Person for whom Trade Contractor is legally responsible, unusually severe weather conditions not customarily encountered in the area surrounding the Project which affect the scheduled Critical Path of the Trade Contractor Work, or any other cause for which the Trade Contractor is not responsible, then the Contract Time, provided for in **Paragraph 4.1** above, shall be extended by a Contract Revision for a reasonable period of time as agreed to by the Authority. No adjustments to the Contract Time are acceptable without the prior written approval of the Authority as a Contract Revision.

**4.6 Contract Time Extensions.** Notwithstanding anything to the contrary in this Trade Contract Agreement, the Trade Contractor agrees that, regardless of the cause of delay and whether or not any extension of Contract Time may be granted therefore, Trade Contractor shall continue to prosecute all Trade Contractor Work not directly affected by said cause of delay and, with respect to such portion or portions of the Trade Contractor Work as may be so affected, shall take all reasonable measures to minimize the effect of said cause of delay. It is a condition precedent to the consideration or prosecution of any Claim for an extension of Contract Time that the foregoing provisions be strictly adhered to in each instance and, if the Trade Contractor fails to comply, Trade Contractor shall be deemed to have waived the Claim to the extent that proper mitigation would have shortened the period of delay. The Trade Contractor further acknowledges and agrees that adjustments in the Contract Time will be permitted for a delay only to the extent such delay (a) is not caused, or could not have been reasonably avoided, by the Trade Contractor, or (b) could not be reasonably limited or avoided by the Trade Contractor's timely notice to the Authority of the delay or reasonable likelihood that a delay will occur.

**4.7 Progress Report.** If the Trade Contractor submits a progress report indicating, or otherwise expresses an intention to achieve, completion of the Trade Contractor Work prior to any completion date required by the Trade Contract Documents or expiration of the Contract Time, no liability of the Authority to the Trade Contractor for any failure or inability of the Trade Contractor to so complete the Trade Contractor Work shall be created or implied.

**4.8 Partial Use.** The Authority shall have the right to use, without prejudice to rights of either Party, any completed or Substantially Completed portions of the Trade Contractor Work, notwithstanding the fact that time for completion of entire Trade Contractor Work, or portions thereof, may not be expired. Use by Authority shall not constitute, in itself, acceptance of the Trade Contractor Work.

**4.9 to 4.16 [RESERVED]**

**4.17 Royalties and Patents.** The Trade Contractor shall pay all royalties and license fees. The Trade Contractor shall defend suits or claims for infringement of patent rights and shall hold the Authority and all Indemnitees harmless from loss on account thereof.

**4.18 Indemnification by Trade Contractor.**

**4.18.1** To the fullest extent permitted by Applicable Laws, Trade Contractor hereby agrees to indemnify, hold harmless, and defend the Authority and Indemnitees from and against any and all claims, damages, liabilities, losses and expenses (specifically including reasonable attorneys' fees and costs, court fees and costs, and arbitration fees and costs incurred to defend the Authority and Trade Contractor's liability shall not be limited by the amount or limit of insurance Trade Contractor procures to insure its obligations to the Authority or Indemnitees), provided that such claims, damages, losses or expenses arise out of bodily injury, sickness, disease or death, or to injury to or destruction of tangible property (other than the Trade Contractor Work itself), but only to the extent arising out of, resulting from, or incurred in connection with the performance of the Trade Contractor Work and to the extent in whole or in part caused or alleged to have been caused by the negligent or grossly negligent acts or omissions, of the Trade Contractor, Trade Contractor's employees, Subcontractors, Sub-Subcontractors, Suppliers or any Person for whom the Trade Contractor is legally responsible in the performance of the Trade Contractor Work under this Trade Contract Agreement, whether arising before or after completion of the Trade Contractor Work and arising out of, resulting from, or occurring in connection with the performance of the Trade Contractor Work or any activity associated with the Trade Contractor Work, from any activity of the Trade Contractor, Trade Contractor's employees, its Subcontractors, Sub-Subcontractors, Suppliers, their agents, or employees at the Project Site or elsewhere, and whether in part caused by the active or passive negligence or other fault of a

Party or Person indemnified hereunder, excepting only personal injury to Persons or damage to property found to have been caused by the sole negligence of a Party or Person indemnified hereunder. Such obligations shall not be construed to negate, abridge, or reduce other rights or obligations of indemnity that would otherwise exist as to a Party or Person described in this **Subparagraph 4.18.1.**

**4.18.2** Trade Contractor acknowledges and agrees that it has an independent obligation under this Trade Contract Agreement to procure and maintain contractual liability coverage insurance as will insure Trade Contractor's obligations in this **Paragraph 4.18**, and further acknowledges that such insurance is commercially available. Trade Contractor's liability shall not be limited by the amount or limit of insurance Trade Contractor procures to insure its obligations herein. Trade Contractor agrees and acknowledges that such contractual liability coverage is for the benefit of the Authority and Indemnitees, but does not require Trade Contractor to provide such insurance directly to the Authority and Indemnitees.

**4.18.3** In addition to its duties under **Paragraph 4.18** herein, the Trade Contractor shall defend, indemnify, and hold harmless the Authority and the Indemnitees from and against any and all alleged claims, damages, liabilities, losses and expenses (specifically including reasonable attorneys' fees and costs, court fees and costs, and arbitration fees and costs incurred to defend the Authority and Indemnitees) caused by Trade Contractor's breach of this Trade Contract Agreement to the extent finally determined. For the purpose of this **Subparagraph 4.18.3**, the Authority's or an Indemnitee's tender shall not be deemed to require proof of the Trade Contractor's breach of contract at the time of tender.

**4.18.4** In the case of claims against any Party or Person indemnified under this **Paragraph 4.18** by an employee of the Trade Contractor, a Subcontractor, anyone directly or indirectly employed by them, or anyone for whose acts they may be liable, the indemnification obligation under this **Paragraph 4.18** shall not be limited by a limitation on amount or type of damages, compensation, or benefits payable by or for the Trade Contractor or a Subcontractor under workers' compensation acts, disability benefit acts, or other employee benefit acts.

**4.18.5** The Trade Contractor shall indemnify the Authority, Indemnitees, and the respective directors, officers, agents, and employees of any of them from and against any and all costs and expenses, specifically including reasonable attorneys' fees and costs, court fees and costs, and arbitration fees and costs, incurred by any of the foregoing Parties or Persons to enforce any of the Trade Contractor's defense, indemnity, and hold-harmless obligations under this Trade Contract Agreement.

**4.18.6** The Trade Contractor's obligation to defend as set forth in **Subparagraphs 4.18.1** and **4.18.3** includes the obligation to provide and pay for attorneys to defend the Party or Persons entitled to indemnification under **Subparagraphs 4.18.1** and **4.18.3**, which attorneys shall be subject to the approval of such Party and Persons; and if such Party or Persons do not approve the attorneys provided by the Trade Contractor, the Trade Contractor shall promptly pay the attorneys' fees incurred by the Party or Persons entitled to indemnification

**5. Trade Contract Amount**

**5.1** The Trade Contract Amount shall be as set forth on **Exhibit 2**.

**6. Record Retention, Audit and Claims**

**6.1** The Trade Contractor shall keep full and detailed accounts and exercise such controls as may be necessary for proper financial management under this Trade Contract Agreement and as directed and approved by the Authority and Team. Trade Contractor shall afford the Authority reasonable access to appropriate personnel for interviews and the necessary and relevant records, books, cost reports, labor rates, labor schedules, correspondence, instructions, drawings, receipts, Subcontracts, purchase orders, vouchers, memoranda, and other electronic and hard copy data to the extent relating to the Trade Contractor's right to payment under and the Trade Contractor's compliance with the terms and conditions of this Trade Contract Agreement, and the Trade Contractor shall preserve this information for a period of seven (7) years after final payment, or for such longer period as may be required by Applicable Laws. The Trade Contractor shall account for and keep track of the Cost of the Trade Contractor Work, including all materials, equipment and labor utilized in the performance of the Trade Contractor Work, and shall keep such full and detailed accounts as may be necessary for proper financial management under this Trade Contract Agreement. Subcontractors retained by the Trade Contractor on a "cost-plus" basis shall have the same obligations to retain records and cooperate with audits as are required of the Trade Contractor under this **Paragraph 6.1**. In addition to all other rights under the Trade Contract Documents, the Authority and Team representatives shall have the right to conduct full and complete audits of the Trade Contractor with respect to the Trade Contractor Work and also to the extent relating to the Trade Contractor's right to payment under and the Trade Contractor's compliance with the terms and conditions of this Trade Contract Agreement. The Trade Contractor shall provide the Authority and Team copies of all documents and records associated with the Work that the Authority or Team deem necessary. The Trade Contractor shall provide all Subcontracts, material purchase orders, and insurance certificates to the requesting party in an executed format for all Subcontractors and Suppliers prior to any such Person commencing work on the Project.

## 6.2 Claims and Disputes

**6.2.1 Definition.** A “Claim” is a demand or assertion by a Person seeking as a matter of right, adjustment or interpretation of terms of an agreement, payment of money, extension of time, or other relief with respect to the terms of the Trade Contract Documents. The term “Claim” also includes, without limitation, other disputes and matters in question between the Authority and the Trade Contractor, between the Architect and the Construction Manager, between the Authority and the Architect or between the Authority and the Construction Manager arising out of or relating to the applicable Contract Documents or Trade Contract Documents. Claims must be made by written notice provided by the claimant to the Party against whom the Claim is being made, with a copy to the Authority. The responsibility to substantiate Claims shall rest with the party making the Claim.

**6.2.2 Referral to Authority.** Claims, including those alleging an error or omission by the Trade Contractor will be referred initially to the Authority for action as provided in **Paragraph 6.3**. The recommendation by the Authority, if any, in response to a Claim shall not be a condition precedent to arbitration or litigation.

**6.2.3 Time Limits on Claims.** Except as provided in **Subparagraph 6.2.6** below, and except for Claims asserted by the Authority, Claims by any Person that are discovered during the performance of the Trade Contractor Work must be made within twenty-one (21) Days after occurrence of the event giving rise to such Claim or within twenty-one (21) Days after the claimant first recognizes the condition giving rise to the Claim, whichever is later, or said Claim shall be deemed waived. In addition to the foregoing, as soon as the claimant recognizes the conditions giving rise to the Claim, claimant shall provide notice of such conditions to the Authority, and shall use its best efforts to cooperate with the Authority and the Party against whom the Claim is made in any effort to mitigate the alleged or potential damages, delay, or other adverse consequences arising out of the condition which is the cause of such a Claim. Any additional Claim related to the initial Claim that is made after the initial Claim has been adjusted and dealt with by Contract Revision will not be considered. Claims may also be reserved in writing within the time limits set forth in this **Subparagraph 6.2.3**. If a Claim is reserved, the Resolution of Claims and Disputes procedures described in **Paragraph 6.3** and **Paragraph 6.4** hereof shall not commence until a written notice from the claimant is received by the Authority. Any notice of Claim or reservation of Claim must clearly identify the alleged cause and the nature of the Claim and include data and information then available to the claimant that will facilitate prompt verification and evaluation of the Claim, and it shall be assumed that the Authority has been prejudiced if it does not receive said information.

**6.2.4 Continuing Contract Performance.** Pending final resolution of a Claim, unless otherwise agreed in writing, the Trade Contractor shall proceed diligently with performance of its Trade Contractor Work, and the Authority shall continue to make payments in accordance with the Trade Contract Documents. In the event the Trade Contractor fails to diligently proceed with its Trade Contractor Work during a period of dispute resolution, the Authority may procure necessary replacement services or work and back-charge all associated costs to the non-performing party.

**6.2.5 Injury or Damage to Person or Property.** If during the performance of the Trade Contractor Work any member of the Project Team suffers injury or damage to person or property because of an act or omission of any other member of the Project Team, such other party's employees or agents, or others for whose acts such member of the Project Team is legally liable, written notice of such injury or damage, whether or not insured, shall be given to the other member of the Project Team within a reasonable time not exceeding twenty-one (21) Days after first observance of the injury or damage. The notice shall provide sufficient detail to enable the other members of the Project Team to investigate the matter.

**6.2.6 Claims for Concealed or Differing Site Conditions.** Notwithstanding anything to the contrary in the Trade Contract Documents, the Trade Contractor acknowledges and agrees that it has thoroughly investigated the existing design and construction of the Project and the future anticipated construction of the Project, and hereby waives any Claims for conditions encountered at the Project Site which are (a) subsurface or otherwise concealed physical conditions which differ materially from those indicated in the Trade Contract Documents, the design of the Project prepared by the Architect, or existing construction and (b) unknown physical conditions of an unusual nature, which differ materially from those ordinarily found to exist and generally recognized as inherent in construction activities of the character provided for in the Trade Contract Documents or the design of the Project prepared by the Architect. The Trade Contractor acknowledges and agrees that this exclusion of Claims for differing site conditions has been specifically negotiated and that the Trade Contract Amount in **Exhibit 2** contains an adequate and fair contingency to address this specific risk among others.

**6.2.7 Claims for Cost.** If the Trade Contractor wishes to make a Claim for an increase in the Trade Contract Amount, written notice to the Authority as strictly set forth under this **Paragraph 6.2** is required and shall be given before the Trade Contractor proceeds to execute the Trade Contractor Work or the Trade Contractor's Claim shall be deemed waived. Any Trade Contractor Work completed by the Trade Contractor without the proper notice to and approval by the Authority will not be considered or approved as a change to the Trade Contract Amount. Prior notice is not required for Claims relating to an emergency endangering life or property pursuant to **Paragraph 13.4**

below. If the Trade Contractor believes additional cost above the Trade Contract Amount are involved for reasons including but not limited to (a) written interpretation from the Authority, (b) an order by the Authority to stop the Trade Contractor Work where the Trade Contractor was not at fault, (c) a written order for a minor change in the Trade Contractor Work issued by the Architect, (d) other reasonable grounds, the Claim shall be filed in accordance with the procedure established herein.

**6.2.8 Claims for Additional Time.** If the Trade Contractor wishes to make a Claim for an increase in the Contract Time, written notice shall be given within the time period specified in **Subparagraph 6.2.3** or said Claim shall be deemed waived. The Trade Contractor's Claim shall include an estimate of cost and of probable effect of delay on progress of the Trade Contractor Work and the Construction Schedule. In the case of a continuing delay only one Claim is necessary. If adverse weather conditions are the basis for a Claim for additional time, such Claim shall be documented by data substantiating that weather conditions were abnormal for the period of time and could not have been reasonably anticipated, and that weather conditions had an adverse effect on the Construction Schedule.

**6.2.9 Claims for Consequential Damages.** Except as provided in **Exhibit 6**, the Trade Contractor and the Authority waive Claims against each other for consequential damages arising out of or relating to the Trade Contractor Work. This mutual waiver includes:

.1 damages incurred by the Authority for rental expenses, for losses of use, income, profit, financing, business and reputation, and for loss of management or employee productivity or of the services of such Persons; and

.2 damages incurred by the Trade Contractor for labor, material, or principal office costs or expenses including the compensation of personnel stationed there, for losses of financing, business and reputation, and for loss of profit except anticipated profit arising directly from the Trade Contractor Work.

This mutual waiver is applicable, without limitation, to all consequential damages due to either party's termination in accordance with **Article 16** below. Nothing contained in this **Subparagraph 6.2.9** shall be deemed to preclude an award of liquidated damages, when applicable, in accordance with the requirements of **Exhibit 6**. In addition, this **Subparagraph 6.2.9** does not apply to or preclude the Authority's right to recover consequential damages to the extent provided below. Notwithstanding anything to the contrary, the Authority does not waive and specifically reserves all rights and claims to recover any and direct damages, indirect damages, incidental damages, consequential, damages incurred by the Authority and



Indemnitees, including rental expenses, for losses of use, income, profit, financing, business and reputation, and for loss of management or employee productivity or the services of such Persons, and any other type or form of damages (“**Reserved Damages**”) against the Trade Contractor to the extent that such claims for Reserved Damages are due to the need to repair the Trade Contractor’s improper or defective Trade Contractor Work after Substantial Completion or are covered by any insurance available under the OCIP program or under the Trade Contractor’s insurance program.

### **6.3 Review of Claims and Disputes**

**6.3.1** The Authority, will review all Claims once submitted by the Trade Contractor and take one or more of the following preliminary actions within ten (10) Days of receipt of a Claim: (a) request additional supporting data from the claimant, (b) submit a schedule to the parties indicating when the Authority expects to take action, (c) reject the Claim in whole or in part, stating reasons for rejection, (d) recommend approval of the Claim, (e) suggest a compromise, or (f) not take any of the above actions, in which case the Claim shall be deemed denied. The Authority may also, but is not obligated to, notify the Trade Contractor’s surety, if any, of the nature and amount of the Claim.

**6.3.2** If a Claim submitted to the Authority has been resolved, the Authority will prepare or obtain appropriate documentation to memorialize and process the resolution.

**6.3.3** If a Claim submitted to the Authority has not been resolved after consideration of the foregoing and of further evidence presented by the parties or requested by the Authority, the Authority will, in a timely fashion, notify the parties in writing that the Authority’s recommendation will be made within seven (7) Days. Upon expiration of such time period, the Authority will render to the parties its final recommendation relative to the Claim including any change in the Trade Contract Amount or Contract Time or both. The parties may then (a) agree to resolve the Claim or (b) proceed pursuant to **Paragraph 6.4** hereof. If the Authority’s recommendation is not submitted within thirty (30) Days of the Authority’s receipt of the Claim, the Claim shall be deemed denied.

### **6.4 Dispute Resolution**

**6.4.1 Mediation.** Claims, disputes, or other matters in controversy arising out of or related to the Trade Contractor Work shall be subject to mediation as a condition precedent to binding dispute resolution. The Parties shall submit a written demand for mediation to the Authority, which shall describe in detail the facts and circumstances of the dispute. The Authority shall designate a neutral third-party to serve as mediator. The mediator shall hear the matter in Minneapolis, Minnesota, and provide an informal opinion and

advice, none of which shall be binding on the Parties involved in the dispute. The opinion shall be submitted to the parties in dispute within twenty (20) Days of the mediator hearing the dispute. The Parties in dispute will then agree within ten (10) Days to resolve the dispute pursuant to the mediator's advice or submit the matter to arbitration pursuant to **Subparagraph 6.4.2**. The mediator's costs shall be shared equally by the Parties in the dispute. The request to mediate may be made concurrently with the filing of binding dispute resolution proceedings but, in such event, mediation shall proceed in advance of binding dispute resolution proceedings, which shall be stayed pending mediation for a period of sixty (60) Days from the date of filing, unless stayed for a longer period by agreement of the Parties or court Order. If an arbitration is stayed pursuant to this **Subparagraph 6.4.1**, the Parties may nonetheless proceed to the selection of the arbitrator(s) and agree upon a schedule for later proceedings.

**6.4.2 Claims Subject to Arbitration.** Any Claim subject to, but not resolved by, mediation shall be subject to arbitration, which shall be administered by the American Arbitration Association in accordance with its Construction Industry Arbitration Rules ("**AAA Rules**") in effect as of the Effective Date of this Trade Contract Agreement. The Party filing a notice of demand for arbitration must assert in the demand all Claims then known to that Party on which arbitration is permitted to be demanded. All proceedings set forth under this **Paragraph 6.4** shall be conducted in Minneapolis, Minnesota.

**6.4.3 Notice for Arbitration.** Notice of Demand for Arbitration shall be filed, in writing, with the other Party to the applicable agreement, with any Party to be joined pursuant to **Subparagraph 6.4.6** hereof, and with the American Arbitration Association, the Authority, Trade Contractor, Construction Manager, and the Architect, to the extent they are not otherwise a Party to the arbitration. At the Authority's election, and its sole discretion, it may invoke application of Fast Track Procedures under the AAA Rules for any such arbitration proceedings initiated under the Contract Documents. The Trade Contractor acknowledges and agrees that Minn. Stat. § 544.42 does not apply to this Project.

**6.4.4 Contract Performance During Arbitration.** During arbitration proceedings, the Authority, Trade Contractor, Architect, Construction Manager and any Subcontractor or Subconsultant shall comply with **Subparagraph 6.2.4** hereof.

**6.4.5 When Arbitration May Be Demanded.** A demand for arbitration shall be made no earlier than concurrently with the filing of a request for mediation, but in no event shall it be made after the date when the institution of legal or equitable proceedings based on the Claim would be barred by the applicable statute of limitations or repose. For statute of limitations purposes, receipt of a written demand for arbitration by the Person administering the

arbitration shall constitute the institution of legal or equitable proceedings based on the Claim.

**6.4.6 Consolidation or Joinder.** Any arbitration shall include, by consolidation or joinder, the Construction Manager, Architect, Subcontractors, Suppliers, Subconsultants, Trade Contractors, and other Persons bound to arbitrate according to this **Paragraph 6.4** if substantially involved in a common question of fact or law. The foregoing agreement to arbitrate and consolidation and joinder shall be specifically enforceable under Applicable Laws in any court having jurisdiction thereof. Any contract between the Trade Contractor and any Subcontractor and Supplier and contracts between Subcontractors and Suppliers and lower tiers of Sub-Subcontractors and suppliers shall include provisions for arbitration, consolidation, and joinder consistent with this **Paragraph 6.4**.

**6.4.7 Judgment on Final Award.** The award rendered by the arbitrator or arbitrators shall be final, and judgment may be entered upon it in accordance with Applicable Laws in any court having jurisdiction thereof.

**6.4.8 Litigation of Third-Party Claims.** If a third-party who is not a member of the Project Team sues a member of the Project Team, the Authority, or Team in a court of law ("**Third-Party Suit**"), then the Authority, or the Team as applicable, shall have the absolute discretion to join in the Third-Party Suit members of the Project Team who are involved in common questions of law or fact or whose participation is necessary to provide complete relief in the Third-Party Suit, and the Authority, and the Team as applicable, have the absolute discretion to decide to waive and not require arbitration of Claims involving the Third-Party Suit as otherwise provided in these Terms of Design and Construction. The Project Team hereby consents to jurisdiction and venue in any court in which the suit is commenced or to which such Third-Party Suit is removed.

**6.4.9 Attorneys' Fees and Costs.** If any legal action, litigation or other proceeding, including arbitration, is brought for the enforcement of this Trade Contract Agreement or the Trade Contract Documents and/or because of an alleged dispute, breach, default or misrepresentation in connection with any provision of the Trade Contract Documents, the prevailing Party shall be entitled to recover, in addition to all other amounts awarded, reasonable attorneys' fees all reasonable costs and fees associated with paralegal, experts, consultants, or others engaged for the purposes of the litigation or proceeding, in addition to court costs, the expenses of arbitration, and other reasonable costs bringing or defending the action, and, in addition, any other relief of which it may be entitled.

## 7. Changes

**7.1 Contract Request.** All changes to the Trade Contractor Work must be approved in strict accordance with the requirements of this Trade Contract Agreement. No change in the Trade Contractor Work, in any form, will be approved without the Trade Contractor providing the Authority with all reasonably required documentation, including a properly completed Contract Request Form, which will be provided by the Authority. The Contract Request Form, and all required contractual documentation associated therewith and required by the Authority, must be provided to and approved by the Authority in writing before commencement of any proposed changes in any part of the Trade Contractor Work. The Authority will administer a Pending Change Report to identify and track any and all potential changes in the Trade Contractor Work, and the Trade Contractor is obligated to provide all supporting documentation reasonably required by the Authority to administer the Pending Change Report. The Authority will use the Pending Change Report to provide the Trade Contractor with written authorization to proceed with commencing approved changes, if any, to the Trade Contractor Work. The Trade Contractor is responsible to immediately provide the Authority with timely notification of any pending change associated with the Trade Contractor Work in accordance with the requirements of this **Paragraph 7.1** and the Trade Contract Documents and to provide projected cost impacts, if any, within five (5) Days of notification of such change. The Trade Contractor is responsible to provide final costs associated with any pending change within two (2) weeks of inclusion on the Pending Change Report, or such other timeframe as reasonably agreed to in writing by the Authority. If the Trade Contractor performs any alleged change in the Trade Contractor Work in the absence of proper notice required by the Trade Contract Documents, the Trade Contractor then assumes all liability for such Trade Contractor Work, understands and agrees that the Trade Contractor will not be paid for such Trade Contractor Work, and agrees that the Authority is not obligated to compensate the Trade Contractor for such alleged change as a Cost of the Trade Contractor Work or as an addition to this Trade Contract Amount.

**7.2 Contract Revision.** A Contract Revision related to the Trade Contractor Work is a written order signed by the Authority and Trade Contractor, and issued after execution of this Trade Contract Agreement, stating their agreement with respect to a Change in the Trade Contractor Work, and which may include an adjustment in the Trade Contract Amount and/or an adjustment to the Construction Schedule or Contract Time. Costs to the Authority resulting from a Change in the Trade Contractor Work shall be determined in writing between the Authority and the Trade Contractor before issuance of any Contract Revision. The Trade Contractor shall not proceed with any Changes in the Trade Contractor Work either without a prior written authorization from the Authority, or if the Authority does not consider the Trade Contractor Work in question to be a Change in the Trade Contractor Work, then without a written notice of Claim as provided herein. The Trade Contractor agrees that it will not be paid for and waives any Claim for payment associated with any alleged Change in the Trade Contractor Work or any Contract Revision unless the

Trade Contractor fully complies with the terms of this **Paragraph 7.2** and the notice of Claims provision **Paragraph 6.2**. The Trade Contractor further assumes any and all risks or liabilities associated with the Trade Contractor proceeding with any alleged Change to the Trade Contractor Work or any pending Contract Revision that is not administered, or preserved by a written notice of Claim, in strict accordance with the Trade Contract Documents. Except as otherwise set forth therein, any executed Contract Revision shall constitute a final settlement of all matters relating to or arising out of the change in the Trade Contractor Work which is the subject of the Contract Revision, including all direct and indirect costs associated with such change and any and all adjustments to the Trade Contract Amount and the Construction Schedule or Contract Time.

**7.3 Construction Change Directive.** A “**Construction Change Directive**” is a written order prepared by the Authority, directing a change in the Trade Contractor Work. The Authority may by Construction Change Directive, without invalidating the Trade Contract Documents, order changes in the Trade Contractor Work within the general scope of the Trade Contract Documents consisting of additions, deletions, or other revisions, the Trade Contract Amount and Contract Time being adjusted, if appropriate. A Construction Change Directive shall be used in the absence of total agreement on the terms of a Contract Revision. No adjustment to the Contract Time shall be made or allowed if the Construction Change Directive does not cause a delay to the Critical Path of the Construction Schedule.

**7.3.1** If the Construction Change Directive does not provide for an adjustment to the Trade Contract Amount, any adjustment shall be based on one of the following methods:

- .1 mutual acceptance of a lump sum properly itemized and supported by efficient substantiating data to permit evaluation;
- .2 unit prices stated in the Trade Contract Documents or subsequently agreed upon; or
- .3 actual costs of the Trade Contractor Work.

## **8. Subcontractors**

**8.1 Award of Subcontractors.** Any Subcontractor that the Trade Contractor proposes to use to perform a part of the Trade Contractor Work shall be subject to the approval of the Authority, which shall not be unreasonably withheld. Before this Trade Contract Agreement is executed, the Trade Contractor shall furnish the Authority, in writing, with (a) the name, trade and subcontract amount of all Persons and entities proposed as Subcontractors, and (b) the names of all Persons or entities proposed as Suppliers of the material or equipment identified in the Specifications (including those who are to furnish materials or equipment fabricated to a special design) and, where applicable, the name of the installing Subcontractor. The Authority will promptly reply to the Trade Contractor in writing stating whether or

not the Authority, after due investigation, has reasonable objection to any such proposed person or entity.

**8.2 Subcontract Relations.** Each Subcontract shall obligate the Subcontractor, to the extent applicable to the Trade Contractor Work performed by the Subcontractor, to assume toward the Trade Contractor and the Authority all the responsibilities, terms and conditions of the Trade Contract Agreement that the Trade Contractor assumes toward the Authority. The Trade Contractor shall make available to each proposed Subcontractor, prior to the execution of the Subcontract, copies of the Trade Contract Documents applicable to the Subcontractor's portion of the Trade Contractor Work, except Trade Contractor may redact pricing and other sensitive information from the copies provided to the Subcontractors.

**8.3 Contingent Assignment of Subcontracts.** Each Subcontract for a portion of the Trade Contractor Work is assignable by the Trade Contractor to the Authority provided that:

.1 assignment is effective only after termination of the Trade Contractor Work or stoppage of Trade Contractor Work by the Authority as provided in the Trade Contract Agreement and only for those Subcontracts which the Authority accepts by notifying the Subcontractor in writing in the Authority's sole discretion; and

.2 assignment is subject to the prior rights of the Trade Contractor's surety, obligated under bonds relating to the Trade Contractor Work.

**8.4 Authority's Rights to Perform Construction.** The Authority reserves the right to perform construction or operations related to the Project with the Authority's own forces and to award separate Trade Contracts or Vendor Contracts in connection with other portions of the Project or other construction or operations on the Project Site under conditions substantially similar to this Trade Contract Agreement, including those portions related to insurance and waiver of subrogation.

**8.5 Payments to Subcontractors and Suppliers.** Before making payments to any of its Suppliers or Subcontractors, Trade Contractor shall obtain lien waivers from all Subcontractors and Suppliers providing services, materials or work to Trade Contractor on the Project and representation from said Subcontractors and Suppliers that their work is free and clear of liens, Claims, security interests, or encumbrances. The Trade Contractor further expressly undertakes to defend and indemnify the Authority and the Indemnitees, at the Trade Contractor's sole expense with independent counsel of the indemnified party's choice, against any actions, lawsuits, or proceedings brought against the Authority or any Indemnitee as a result of Claims or liens filed against the Trade Contractor, the Trade Contractor Work, the Project Site, any improvements thereon, or any portion of the property of the Authority or any Indemnitee, and the Trade Contractor hereby agrees to pay any judgment or Lien resulting from any such actions, lawsuits or proceedings.

## 9. Coordination with Construction Manager

**9.1 Project Schedule.** The Trade Contractor will be responsible for coordinating and scheduling with the Construction Manager. The Trade Contractor shall be responsible for managing and administering the coordination and integration of the Trade Contractor Work with the work of other Trade Contractors and Vendors being performed at the Project Site.

**9.2 Coordination.** The Trade Contractor shall afford the Authority, Construction Manager, other Trade Contractors and Vendors reasonable opportunity for introduction and storage of their materials and equipment and performance of the work other Trade Contractors or Vendors at the Project Site. The Trade Contractor shall properly and fully connect and coordinate its Trade Contractor Work with the work of other Trade Contractors or Vendors so as not to interfere with or to delay the work of such other Trade Contractors or Vendors.

**9.3 Damage.** The Trade Contractor shall promptly remedy damage caused by the Trade Contractor to completed or partially completed construction or to property of the Authority or work of other Trade Contractors or Vendors. The Trade Contractor shall reimburse the Authority for costs incurred by the Authority which are payable to other Trade Contractors or Vendors because of delays, improperly timed activities, defective Trade Contractor Work or other errors or omissions of the Trade Contractor.

**9.4 Claims.** Claims and other disputes and matters in question between the Construction Manager and the Trade Contractor or Vendor shall be subject to the provisions of **Paragraphs 6.2 - 6.4.**

## 10. Compliance with Applicable Law

**10.1 Equity Plan.** The Trade Contractor shall comply with all Applicable Laws and any special requirements in the Contract Documents regarding equal employment opportunity, Targeted Business, and workforce participation initiatives. The Trade Contractor shall demonstrate good faith efforts to utilize minority (“**MBE**”) and women-owned (“**WBE**”) business enterprises (hereinafter referred to as “**Targeted Businesses**”). The Authority may retain the services of a Targeted Business Coordinator to assist with meeting Targeted Business and workforce participation goals. The Trade Contractor shall submit to the Authority a Targeted Business Enterprise Participation Plan within ten (10) Days after executing this Trade Contract Agreement. The Authority requires that the Trade Contractor utilize good faith efforts to achieve the goals for MBE and WBE participation set forth in the Authority’s Equity Plan for the Trade Contractor Work. The Authority also requires that the Trade Contractor utilize good faith efforts to achieve the workforce participation goals for minority and women workers regarding the Trade Contractor Work. The Authority agrees that it will follow the Equity Plan provided on the Authority’s website at: <http://www.msfa.com/content/EQUITY%20PLAN/FINAL%20EQUITY%20PLAN%202.8.13.pdf>

The Trade Contractor agrees that the Equity Plan is applicable to its Trade Contractor Work and specifically agrees to submit the forms attached hereto as **Exhibit 3** (Targeted Business Commitment and Information Form), **Exhibit 4** (Targeted Business Information Form), and **Exhibit 5** (TCA Equity Plan Progress Report).

The Trade Contractor shall utilize the Targeted Business Coordinator to the fullest extent possible to accomplish the following activities:

- .1 Identify the trades, services and suppliers needed for the Trade Contractor Work.
- .2 Identify Targeted Businesses that have the resources and capabilities to participate in the Trade Contractor Work.
- .3 Contact Targeted Businesses to solicit bids for work on the Trade Contractor Work.
- .4 Certify currently uncertified but qualified companies as Targeted Businesses for participation in the Trade Contractor Work.
- .5 Develop the Targeted Business Enterprise Participation Plan for submittal with any bid or proposal from a Subcontractor.
- .6 Track participation of Targeted Businesses.
- .7 Prepare Targeted Business participation reports required by the Authority.
- .8 Comply with workforce utilization requirements of the Authority's Equity Plan for the Trade Contractor Work, including requirements established pursuant to Section 17, subd.1 of the Act.

Trade Contractor's failure to use good faith efforts to achieve the Authority's Targeted Business participation goals or to follow the requirements of the Authority's Equity Plan for the Trade Contractor Work may result in the assessment of appropriate damages.

## **11. Payments**

**11.1 Amount Payable.** The Trade Contract Amount is the maximum total amount payable to the Trade Contractor for performance of the Trade Contractor Work under the Trade Contract Agreement.

**11.2 Schedule of Values.** The Trade Contractor shall submit to the Authority a Schedule of Values allocated to various portions of the Trade Contractor Work, prepared in such form and supported by such data to substantiate its accuracy as the Authority deems necessary. The Authority shall have the right to approve the Trade Contractor's format of the Schedule of Values and all subsequent forms of the Schedule of Values. The Schedule of Values shall be used by the Authority as a basis for reviewing the Trade Contractor's Applications for Payment.

**11.2.1** Any Schedule of Values that fails to include sufficient detail, is unbalanced, or exhibits "front-end loading" of the value of the Trade Contractor Work shall be rejected. If a Schedule of Values had been initially



approved and subsequently used, but later found improper for any reason, sufficient funds shall be withheld from future Applications for Payment to ensure an adequate reserve, exclusive of normal retainage, to complete the Trade Contractor Work.

**11.3 Applications for Payment.** The Trade Contractor shall submit to the Authority an itemized Application for Payment for completed portions of the Trade Contractor Work in accordance with the Schedule of Values. Such Application for Payment shall be notarized, if required, and supported by such data substantiating the Trade Contractor's right to payment as the Authority may require. Such Applications for Payment may include requests for payment on account of changes in the Trade Contractor Work that have been properly authorized by Construction Change Directives, but not yet included in a Contract Revision. Such Applications for Payment shall not intentionally include requests for payment of amounts the Trade Contractor does not intend to pay to a Subcontractor or Supplier because of a dispute or other reason unless the Trade Contractor has properly performed the Trade Contractor Work for which payment is being requested in lieu of the Subcontractor or Supplier. By signing and submitting an Application for Payment, Trade Contractor shall represent and warrant that Trade Contractor has no Knowledge of and waives any Claims, specifically including Claims for any adjustment to the Contract Time or adjustments to the Trade Contract Amount, based on events or circumstances existing or occurring before the date of the subject Application for Payment, except as specifically stated in said Application for Payment or as may have been properly preserved by timely written notice of a Claim as required by the Trade Contract Documents. Each Application for Payment shall be accompanied by the following, all in form and substance satisfactory to the Authority:

.1 A current Trade Contractor's waiver of lien or claim for payment and duly executed and acknowledged sworn statement showing all Subcontractors and Suppliers with whom the Trade Contractor has entered into Subcontracts, the amount of each such Subcontract, the amount requested for any Subcontractor and Supplier in the requested progress payment, and the amount to be paid to the Trade Contractor from such progress payment, together with similar sworn statements from all such Subcontractors and Suppliers;

.2 Duly executed waivers of liens and claims for payment from all Subcontractors, Suppliers, and lower tier Sub-Subcontractors establishing payment or satisfaction of all amounts requested by the Trade Contractor on behalf of such entities or persons in the previous Application for Payment;

.3 Invoices and back-up documentation from any Subcontractor, Supplier, Sub-Subcontractor, or other party to whom the Trade Contractor proposes to make payment under that Application for Payment; and

.4 All information and materials required to comply with the requirements of the Trade Contract Documents, requested by the Authority or reasonably requested by any Lender, Lender's representative and any escrow or disbursement agent or title company, if any, retained by the Authority or any Lender to disburse payments.

**11.4 Materials and Equipment.** Unless otherwise provided in the Trade Contract Documents, payments shall be made on account of materials and equipment delivered and suitably stored at the Project Site for subsequent incorporation in the Trade Contractor Work. If approved in advance by the Authority, payment may be made for materials and equipment suitably stored off the Project Site at a location agreed upon in writing. Payment for materials and equipment stored on or off the Project Site shall be conditioned upon compliance by the Trade Contractor with procedures satisfactory to the Authority to establish the Authority's title to such materials and equipment or otherwise protect the Authority's interests, and shall include applicable insurance, storage, and transportation to the Project Site for such materials and equipment stored off the Project Site. Trade Contractor shall also comply with the following specific requirements:

- .1 The aggregate cost of materials stored off site shall not exceed ten percent (10%) of the Trade Contract Amount at any time without written approval of the Authority;
- .2 Title to such materials shall be vested in the Authority, as evidenced by documentation satisfactory in form and substance to the Authority, including recorded financing statements, UCC filings, and UCC searches;
- .3 With each Application for Payment, the Trade Contractor shall submit to the Authority a written list identifying each location where materials are stored off the Project Site and the value of materials at each location. Trade Contractor shall procure insurance for materials stored off the Project Site in an amount not less than the total value thereof and shall provide satisfactory evidence of such insurance coverage along with the Application for Payment for such materials;
- .4 The consent of any surety shall be obtained to the extent required prior to payment for any materials stored off the Project Site;
- .5 Representatives of the Authority and the Lender's designees shall have the right to make inspections of the storage areas at any time; and
- .6 Such materials shall be (a) protected from diversion, destruction, theft, and damage to the satisfaction of the Authority, (b) specifically marked for use in the Trade Contractor Work, and (c) segregated from other materials at the storage facility.

**11.5 Title to Trade Contractor Work.** The Trade Contractor warrants that title to all Trade Contractor Work covered by an Application for Payment will pass to the Authority no later than the time of payment. The Trade Contractor further warrants that upon submittal of an Application for Payment, all Trade Contractor Work for which Certificates for Payment have been previously issued and payments received from the Authority shall be free and clear of liens, Claims, security interests, or encumbrances in favor of the Trade Contractor, Subcontractors, Suppliers, Sub-Subcontractors, or other Persons able to make a Claim by reason of having provided labor, materials, and equipment relating to the Trade Contractor Work, except as specifically stated in said Application or as may have been properly preserved by timely written notice of a Claim as required by the Trade Contract Documents.

- .1 To the extent of payments received from the Authority, the Trade Contractor further expressly undertakes to defend and indemnify the Authority and the Indemnitees, at the Trade Contractor's sole expense, with independent counsel of the indemnified party's choice, against any actions, lawsuits, or proceedings brought against the Authority or any Indemnitee as a result of Claims or liens filed against the Trade Contractor, the Trade Contractor Work, the Project Site, any improvements thereon, or any portion of the property of the Authority or any Indemnitee. To the extent of payments received from the Authority, the Trade Contractor hereby agrees to indemnify and hold the Authority and all Indemnitees harmless against any such liens or claims of lien and agrees to pay any judgment or lien resulting from any such actions, lawsuits or proceedings.
- .2 The Authority shall release any payments withheld due to a Lien if the Trade Contractor obtains security acceptable to the Authority or a bond which is: (a) issued by a surety acceptable to the Authority, (b) in form and substance satisfactory to the Authority, and (c) in an amount not less than One Hundred Fifty percent (150%) of such Lien claim. By posting a bond or other acceptable security, however, the Trade Contractor shall not be relieved of any responsibilities or obligations under this **Paragraph 11**, including, without limitation, the duty to defend and indemnify the Authority and all Indemnitees. The cost of any premiums incurred in connection with such bonds or security shall be the responsibility of the Trade Contractor and shall not be reimbursable.

**11.6 Approval of Applications for Payment.** Based upon Applications for Payment submitted by the Trade Contractor and as approved by the Authority, the Authority shall make payment to the Trade Contractor. The period covered by each Application for Payment shall be one (1) calendar month ending on the last day of the month, or as otherwise agreed to between the Authority and Trade Contractor in writing. Provided that a Trade Contractor Application for Payment is approved for full or partial payment, the Authority shall make payment of the approved amount to the Trade Contractor not later than forty-five (45) Days after the Authority has approved Application for Payment. Each Application for Payment shall be based upon the most recent Schedule of Values submitted by the Trade Contractor and approved by the Authority in accordance with this Trade Contract Agreement. The Application for Payment shall show the percentage completion of each portion of the Trade Contractor Work as of the end of the period covered by the Application for Payment. The percentage completion shall be the percentage of that portion of the Trade Contractor Work which has actually been completed. Subject to other provisions of the Trade Contract Agreement, the amount of each progress payment shall be computed as follows:

**11.6.1** Determine the portion of the Trade Contract Amount properly allocable to completed Trade Contractor Work as determined by the Authority.

**11.6.2** Add that portion of the Trade Contract Amount properly allocable to materials and equipment delivered and suitably stored at the Project Site for subsequent incorporation in the Trade Contractor Work, or, if approved in advance by the Authority, suitably stored off the Project Site at a location agreed upon in writing.

**11.6.3** Subtract retainage of five percent (5%). The Authority may in its sole discretion approve any deviation from this requirement.

**11.6.4** Subtract the aggregate of previous payments made by the Authority.

**11.6.5** Subtract amounts, if any, for which the Authority has reasonably withheld or denied a Trade Contractor Application for Payment as provided in the Trade Contract Documents.

**11.6.6** The Authority shall pay interest of one and one-half percent (1.5%) per month (or any part of a month) to the Trade Contractor on an undisputed amount not paid to the Trade Contractor. The minimum monthly interest penalty payment for an unpaid balance of \$100 or more is \$10. For an unpaid balance of less than \$100, the Authority shall pay the actual interest penalty due to the Trade Contractor in accordance with Minnesota Statutes.

**11.7 Decisions to Withhold Certification.** The Authority may withhold a Certificate for Payment in whole or in part, to the extent reasonably necessary to protect the Authority, if in the Authority's withholding is justified because of:

**11.7.1** Defective Trade Contractor Work not remedied;

**11.7.2** Third-party claims filed or reasonable evidence indicating probable filing of such claims;

**11.7.3** Failure of the Trade Contractor to properly pay Subcontractors or Suppliers;

**11.7.4** Reasonable evidence that the Trade Contractor Work cannot be completed for the unpaid balance of the Trade Contract Amount or by the required Contract Time;

**11.7.5** Loss or damage incurred by the Authority or another party; or

**11.7.6** Persistent failures to carry out the Trade Contractor Work in accordance with the Trade Contract Documents.

**11.7.7** The Authority shall not be deemed to be in breach of the Trade Contract Documents by reason of the withholding of any payment pursuant to any provision of the Trade Contract Documents.

**11.8 Joint Payments.** To the extent necessary to protect the Authority from Claims, the Authority may make payment by joint payment to the Trade Contractor and the Subcontractors and Suppliers for Trade Contractor Work performed by such Subcontractors and Suppliers. Payments by the Authority shall not constitute approval or acceptance of any item of cost in the Application for Payment.

**11.9 Payments to Subcontractors.** If the Authority makes payment directly to the Trade Contractor for Trade Contractor Work performed by Subcontractors, then the Trade Contractor shall promptly pay each Subcontractor, in accordance with the approved Application for Payment submitted by the Trade Contractor, on account of such Subcontractor's portion of the Trade Contractor Work, the amount to which said Subcontractor is entitled, reflecting percentages actually retained from payments to the Subcontractor on account of such Subcontractor's portion of the Trade Contractor Work. The Trade Contractor must pay any Subcontractor within ten (10) Days of the Trade Contractor's receipt of payment from the Authority for undisputed services provided by the Subcontractor. The Trade Contractor must pay interest of one and one-half percent (1.5%) per month (or any part of a month) to the Subcontractor on any undisputed amount not paid on time to the Subcontractor. The minimum monthly interest penalty payment for an unpaid balance of \$100 or more is \$10. For an unpaid balance of less than \$100, the Trade Contractor shall pay the actual penalty due to the Subcontractor in accordance with Minnesota Statutes. The Trade Contractor shall, by appropriate agreement with the Trade Contractor and each Subcontractor, require each Subcontractor to make payments to Sub-Subcontractors in similar manner upon receipt of payment from the Trade Contractor. The Authority shall have no obligation to pay or to see to the payment of money to a Subcontractor or Supplier.

## **11.10 [RESERVED]**

**11.11 Effect of Payment.** An approved Application for Payment, Certificate for Payment, a progress payment or partial payment of any kind, or partial or entire use or occupancy of the Project by the Authority shall not constitute, nor shall it be construed as, acceptance or approval of any portion of the Trade Contractor Work not in accordance with the Trade Contract Documents or to otherwise relieve the Trade Contractor of any of its obligations hereunder with respect thereto.

**11.12 Reimbursement.** If the Authority is entitled to reimbursement or payment from the Trade Contractor under or pursuant to the Trade Contract Documents such payment shall be made promptly by the Trade Contractor upon demand from the Authority. Notwithstanding anything contained in the Trade Contract Documents to the contrary, if the Trade Contractor fails to promptly make any payment to the Authority which is due to the Authority, or the Authority incurs any costs and expenses to cure any default of the Trade Contractor or to correct defective Trade Contractor Work, the Authority shall have an absolute right to offset such amount against the Trade Contract Amount or any progress payment otherwise due and may, in the Authority's sole discretion, elect either to: (a) deduct an amount equal to that which the Authority is entitled from any payments then or thereafter due the Trade Contractor, or (b) issue a written notice to the Trade Contractor reducing the Trade Contract Amount by an amount equal to that to which the Authority is entitled.

**11.13 Advance Payments.** Except with the Authority's prior written approval, the Trade Contractor shall not authorize advance payments to Suppliers for materials that have not been delivered to and properly stored at the Project Site.

**11.14 Reliance on Information.** In taking action on the Trade Contractor's Application for Payment, the Authority shall be entitled to rely on the accuracy and completeness of the information furnished by the Trade Contractor and shall not be deemed to represent that the Authority has made a detailed examination, audit or arithmetic verification of the documentation submitted by the Trade Contractor or other supporting data, that the Authority has made exhaustive or continuous on-site inspections, or that the Authority has made examinations to ascertain how or for what purposes the Trade Contractor has used amounts previously paid. If requested by the Authority, the Authority's accounting representative, acting in the sole interest of the Authority, will perform such examinations, audits and verifications.

**11.15 Certifications.** The Trade Contractor is required to certify that all amounts owed and requested under the Application for Payment are due to the Trade Contractor, are accurate and correct, and that all of the Trade Contractor Work completed to the date of the Application for Payment has been completed in accordance with the Trade Contract Agreement. The Trade Contractor will be responsible for any errors or inaccuracies in the Application for Payment. The Trade Contractor, and all Subcontractors or other Persons included for payment under the

Trade Contractor's Application for Payment, will be required to certify that they have no Knowledge of any Claims outstanding for any of the Trade Contractor Work completed to the date of the Trade Contractor's Application for Payment, except those Claims that are properly preserved in strict accordance with the Trade Contract Agreement.

**11.16 Subcontractor Work.** Notwithstanding the provisions of **Paragraph 11.15** and notwithstanding the wording of such certificates, the Trade Contractor shall ensure that each Subcontractor's work is satisfactory and in good order pursuant to the Trade Contract Documents pending the issuance of a final Certificate of Payment and the Trade Contractor shall be responsible for ensuring that the correction of defects or Trade Contractor Work not performed regardless of whether or not such defects were apparent when such certificates were issued.

## **12. Final Completion and Final Payment**

**12.1 Final Completion.** Upon receipt of written notice that the Trade Contractor Work is ready for final inspection and acceptance and upon receipt of a final Application for Payment, the Authority will promptly make such inspection and, when the Authority determines that the Trade Contractor Work is acceptable under the Trade Contract Documents, the Trade Contractor Work has been fully performed and the Trade Contractor has achieved Final Completion, the Authority will issue the final Certificate for Payment stating the entire balance found to be due the Trade Contractor and noted in said final Application for Payment is due and payable. All warranties required under the Trade Contract Agreement shall be provided as part of the final Application for Payment. The final Certificate for Payment will not be issued until all warranties have been received and accepted by the Authority.

**12.2 Final Payment.** Final Payment shall be made by the Authority to the Trade Contractor when (a) the Trade Contractor has achieved Final Completion, except for the Trade Contractor's responsibility to correct defective or nonconforming Work and to satisfy other requirements, if any, which necessarily survive Final Payment; (b) a final Application for Payment has been submitted by the Trade Contractor and reviewed by the Authority's accountants; and (c) a final Application for Payment has then been approved in writing by the Authority. The Authority shall make such Final Payment, including any remaining retainage, if all of the Trade Contractor's responsibilities have been satisfied (otherwise any remaining retainage shall be released upon satisfaction of all requirements) not more than ninety (90) Days after approval by the Authority of the final Application for Payment, or as required by Applicable Law. No Final Payment shall be issued until all final Contract Revisions have been issued and executed with each final Change Order and Trade Contractor has provided the Authority with a detailed list of all Claims that are still unresolved at the time Final Payment is requested. The amount of the Final Payment shall be calculated as follows:

**12.2.1** Take the Trade Contract Amount;

**12.2.2** Subtract amounts that the Authority withholds in accordance with the Trade Contract Agreement; and

**12.2.3** Subtract the aggregate of the previous payments made by the Authority.

### **13. Safety**

**13.1 Safety Programs.** The Trade Contractor shall have a Project Safety Program consistent with the Standard of Care and all applicable requirements set forth herein. The Trade Contractor shall be bound by and adhere to any safety program the Construction Manager may have. If the Construction Manager reviews, monitors and/or coordinates with the Trade Contractor's safety programs it shall not relieve the Trade Contractor from controlling its safety programs. The Trade Contractor shall also have controlling employer responsibility for the safety programs and precautions applicable to its Trade Contractor Work and the activities of other work in areas designated as within the control of Trade Contractor. Furthermore, the Trade Contractor agrees that the Trade Contractor will include reasonable precautions for safety of: (a) its employees on the Project and other Persons who may be affected thereby; and (b) all Project Participants. The Trade Contractor will also take reasonable precautions for the protection of the Trade Contractor Work, third-party materials and equipment stored on the Project Site in accordance with the Trade Contractor's direction, and other property at or on Adjacent Property to the Project Site.

**13.1.1** In addition to its defined meaning, for purposes of this **Paragraph 13.1, "Hazardous Materials"** also means any element, compound, mixture, solution, particle or substance which is or may become dangerous, or harmful to the health and the welfare of life or the physical environment if not used, stored or disposed of in accordance with Applicable Laws, including explosives, petroleum products, radioactive materials, hazardous wastes, toxic substances, any **"PCBs"** or **"PCB items,"** as defined in 40 C.F.R. 761.3, and any **"asbestos,"** as defined in 40 C.F.R. 763.63.

**13.1.2** In the event the Trade Contractor encounters on the Project Site existing material reasonably believed to be Hazardous Materials which is not part of or a result of the Trade Contract Work and has not been rendered harmless, the Trade Contractor shall immediately stop the Trade Contractor Work in the area affected and report the condition to the Authority in writing. The Trade Contractor Work in the affected area shall not thereafter be resumed except by written agreement of the Authority, and Trade Contractor, if in fact the material is a Hazardous Material and has not been rendered harmless. The Trade Contractor Work in the affected area shall be resumed in the absence of Hazardous Materials, or when it has been rendered harmless.



**13.2 Safety of Persons and Property.** When use or storage of explosives or other Hazardous Materials or equipment or unusual methods are necessary for execution of the Trade Contractor Work, the Trade Contractor shall exercise utmost care and carry on such activities under supervision of properly qualified personnel. When use or storage of explosives or other hazardous materials or equipment or unusual construction methods are necessary, the Trade Contractor shall give the Authority and the Architect reasonable advance notice in writing.

**13.2.1** The Trade Contractor will take, and require its Subcontractors to take, all reasonable precautions for the protection of:

- .1** the Trade Contractor Work and materials and equipment to be incorporated therein, whether in storage on or off the Project Site, under care, custody, or control of the Trade Contractor or the Trade Contractor's Subcontractors or Sub-Subcontractors; and
- .2** other property at the Project Site or on Adjacent Property, including the Trade Contractor Work, other Trade Contractor work, Vendor work, trees, shrubs, lawns, walks, pavements, roadways, structures, and utilities not designated for removal, relocation, or placement in the course of construction.

**13.2.2** The Trade Contractor shall promptly remedy damage and loss to property referred to in **Subparagraphs 13.2.1.1** and **13.2.1.2** hereof caused in whole or in part by the Trade Contractor, a Subcontractor, a Sub-Subcontractor, or anyone directly or indirectly employed by any of them, or by anyone for whose acts they may be liable and for which the Trade Contractor is responsible under **Subparagraphs 13.2.1.1** and **13.2.1.2**, hereof, except damage or loss attributable to acts or omissions of the Authority, Construction Manager or Architect or anyone directly or indirectly employed by either of them, or by anyone for whose acts either of them may be liable, and not attributable to the fault or negligence of the Trade Contractor. The foregoing obligations of the Trade Contractor are in addition to the Trade Contractor's obligations under **Paragraph 4.18** hereof.

**13.2.3** When all or a portion of the Trade Contractor Work is suspended for any reason, the Trade Contractor shall securely fasten down all coverings and protect the Trade Contractor Work, as necessary, from injury or damage by any cause.

### **13.3 Emergencies**

**13.3.1** The Trade Contractor shall promptly report in writing to the Authority, Construction Manager and Architect all accidents arising out of or in connection with the Trade Contractor Work which cause death, personal injury, or property damage, giving full details and statements of any

witnesses. In addition, if death, serious personal injuries, or serious property damages are caused, the accident shall be reported immediately by telephone or messenger to the Authority, Construction Manager and the Architect.

**13.3.2** In an emergency affecting safety of Persons or property, the Trade Contractor shall act, at the Trade Contractor's discretion, to prevent threatened damage, injury, or loss.

**14. Trade Contractor's Insurance for Purposes of Trade Contractor's Work.**

**14.1 Required Insurance.** Before beginning its Trade Contractor Work, the Trade Contractor shall obtain and maintain the Required Insurance as set forth in **Appendix B**, and fully comply with all provisions thereof unless additional insurance is required by a Contract Revision and/or the insurance referenced is provided through a controlled insurance program. In addition, Trade Contractor shall obtain and maintain, in a company or companies lawfully authorized to do business in the State of Minnesota, such insurance as will protect the Trade Contractor and the Authority from claims set forth below which may arise out of or result from the Trade Contractor's operations and Trade Contractor Work under this Trade Contract Agreement and for which the Trade Contractor may be legally liable, whether such operations be by the Trade Contractor or by a Subcontractor, Sub-Subcontractor or by anyone directly or indirectly employed by any of them, or by anyone for whose acts any of them may be liable:

- .1 claims under workers' compensation, disability benefit and other similar employee benefit acts which are applicable to the Trade Contractor's Work;
- .2 claims for damages because of bodily injury, occupational sickness, disease or death of the Trade Contractor's employees;
- .3 claims for damages because of bodily injury, sickness or disease, or death of any Person other than the Trade Contractor's employees;
- .4 claims for damages insured by usual personal injury liability coverage which are sustained (a) by a Person as a result of an offense directly or indirectly related to employment of such Person by the Trade Contractor, or (b) by another Person;
- .5 claims for damages, other than to the Trade Contractor Work itself, because of injury to or destruction of tangible and intangible property, including loss of use resulting therefrom whether or not the tangible or intangible property is physically injured or destroyed;
- .6 claims for damages because of bodily injury, death of a person or property damage arising out of ownership, maintenance or use of a motor vehicle or equipment;

.7 to the fullest extent permitted by law, claims involving contractual liability insurance applicable to the Trade Contractor's obligations under **Paragraph 4.18** hereof, subject to industry standard policy terms and conditions;

.8 claims for professional liability (errors & omissions) for Trade Contractor's professional design services performed as part of the Trade Contractor Work; and

.9 claims for damages because of loss of capital equipment and tools that are owned or rented by the Trade Contractor or its Subcontractors.

**14.1.1** The Trade Contractor shall, for the protection and benefit of the Authority and the Indemnitees, procure, pay for and maintain in full force and effect, at all times during the performance of the Trade Contractor Work until Final Completion and acceptance of the Trade Contractor Work or for such duration thereafter as required, policies of insurance issued by a responsible carrier or carriers acceptable to the Authority and in form and substance reasonably satisfactory to the Authority which afford the coverages set forth in **Appendix B** hereto. The Authority does not in any way represent that the insurance or limits of insurance specified herein are sufficient or adequate to protect the Trade Contractor, but are merely minimums. If the Trade Contractor procures insurance with limits greater than as the limits specified in **Appendix B**, those greater limits shall apply. In addition to what is specified in this **Paragraph 14** and **Appendix B**, Contractor shall take such steps as it may deem necessary to insure itself against all special and unusual hazards peculiar to this Project.

**14.1.2** The costs of all insurance premiums required under this **Paragraph 14.1** and **Appendix B**, shall be included in the calculation of the Trade Contract Amount as set forth in **Exhibit 2** of the Agreement, unless the Authority elects to implement an owner controlled insurance program. The costs of all associated deductibles required under this **Paragraph 14.1** and **Appendix B**, shall be included in the Trade Contract Amount. The Trade Contractor hereby agrees to deliver to the Authority within ten (10) Days of the date of this Trade Contract Agreement and prior to any equipment or personnel being utilized in connection with the Project or the Trade Contractor Work or brought onto the Project Site, certificates of insurance evidencing the required coverages with limits not less than those specified in **Appendix B**. The receipt by the Authority of such certificates does not constitute approval or agreement by the Authority that the insurance requirements of this Trade Contract Agreement has been met or complied with. The Authority and the Indemnitees shall be included as additional insureds as set forth in **Appendix B**. The Commercial General Liability Policy, Automobile Policy, and Umbrella/Excess Liability Policy obtained under or pursuant to this **Paragraph 14.1** and **Appendix B**, shall each be primary and non-contributory to any valid

and collectible insurance carried separately the Authority, or any of the Indemnitees, except for Builders Risk insurance. Further, the Trade Contractor warrants and represents that it will provide that no less than thirty (30) Days' prior written notice to the Authority and the Indemnitees before any material alteration, cancellation, non-renewal or expiration of the coverage to the insurance it obtains pursuant to this **Paragraph 14.1** and **Appendix B**.

**14.1.3** In no event shall any approval or lack of approval of insurance or receipt or lack of receipt by the Authority of certificates of policies required under this **Paragraph 14.1** and **Appendix B** or failure to demand receipt of such certificates prior to the Trade Contractor commencing the Trade Contractor Work be construed as a waiver by the Authority or any of the Indemnitees of the Trade Contractor's obligations to obtain insurance pursuant to this **Paragraph 14.1** and **Appendix B**. The obligation to procure and maintain any insurance required by this **Paragraph 14.1** and **Appendix B** is a separate responsibility of the Trade Contractor and independent of the duty to furnish a certificate of such insurance policies.

**14.1.4 [RESERVED]**

**14.1.5** Thirty (30) Days prior to the expiration or non-renewal of any insurance required by this **Paragraph 14.1** and **Appendix B**, the Trade Contractor shall supply the Authority with certificates of insurance and amendatory riders or endorsements that clearly evidence the continuation of all coverage in the same manner, limits of protection, and scope of coverage as is required in this **Paragraph 14.1**. In the event any renewal or replacement policy, for whatever reason obtained or required, is written by a carrier other than that with whom the coverage was previously placed, or the subsequent policy differs in any way from the previous policy, the Trade Contractor shall also furnish the Authority with a certified copy of the renewal or replacement policy unless the Authority provides the Trade Contractor with prior written consent to submit only a Certificate of Insurance for any such policy. All renewal and replacement policies shall be in form and substance satisfactory to the Authority and written by carriers acceptable to the Authority.

**14.1.6** Any general aggregate limit under the Trade Contractor's Commercial General Liability Policy and Umbrella/Excess Liability Policy shall apply to this Project separately and shall not require exhaustion of any policies providing Trade Contractor coverage as an additional insured.

**14.1.7** The Trade Contractor shall cause each first-tier Subcontractor to (a) provide insurance in accordance with the terms and conditions of Trade Contractor's standard Subcontract and reasonably satisfactory to the Authority, and (b) name the Construction Manager, Architect, Authority and the Indemnitees as additional insureds under the Subcontractor's Commercial

General Liability Policy. The additional insured endorsement included on the Subcontractor's Commercial General Liability Policy shall state that coverage is afforded the additional insured with respect to claims arising out of ongoing and completed operations performed by or on behalf of the Subcontractor. With the exception of any coverage provided under an Owner Controlled Insurance Program, if the additional insureds have other insurance which is applicable to the Project, such other insurance shall be, for the purposes hereof, on an excess or contingent basis. The amount of the insurer's liability under Subcontractor's insurance policy shall not be reduced by the existence of such other insurance.

## **14.2 Authority's Liability Insurance**

**14.2.1** The Authority shall be responsible for purchasing and maintaining the Authority's liability insurance in an amount to be determined by the Authority in its sole discretion.

**14.2.2** With the exception of any deductibles payable pursuant to an Owner Controlled Insurance Program, any deductibles required to be paid for claims made by the Trade Contractor or Subcontractors against the Authority's liability insurance shall be paid by the claiming Trade Contractor or claiming Subcontractor.

## **14.3 Property Insurance**

**14.3.1** Before any portion of the Trade Contractor Work is commenced, the Trade Contractor shall purchase and maintain property insurance for the Trade Contractor Work at the Project Site or portions thereof and materials stored off the Project Site or being shipped to the Project Site as set forth in Appendix B.

**14.3.2 [RESERVED]**

**14.3.3 [RESERVED]**

**14.3.4 [RESERVED]**

**14.3.5 [RESERVED]**

**14.3.6 [RESERVED]**

**14.3.7** The Authority, Architect, Trade Contractor and Construction Manager waive all rights of subrogation and claims of any sort or kind against each other and any of their respective Subconsultants, Subcontractors, Suppliers, Sub-Subcontractors of all tiers, agents, and employees, whether directly or indirectly through any means through their Subconsultants, Subcontractors, Sub-Subcontractors of all tiers, agents, and employees, for loss or damages

caused by fire or other named perils to the extent covered by property insurance obtained pursuant to this **Paragraph 14.3** or other property insurance applicable to the Trade Contractor Work, except such rights as they have to proceeds of such insurance held by the Authority as fiduciary. The Trade Contract Documents hereby require of the Authority, Architect, Construction Manager, and Trade Contractors, if any, and their Subconsultants, Subcontractors, Sub-Subcontractors of all tiers, agents, and employees of any of them, by appropriate written agreement, to include similar waivers of subrogation each in favor of other parties enumerated herein. All insurance policies required in the Trade Contract Documents shall provide such waivers of subrogation by endorsement or otherwise. A waiver of subrogation shall be effective as to a Person even though that Person would otherwise have a duty of indemnification, contractual or otherwise, did not pay the insurance premium directly or indirectly, and whether or not the Person or entity had an insurable interest in the property damaged. The Trade Contractor shall provide to the Authority, prior to the commencement of the Trade Contractor Work, evidence that all of the insurance policies required herein contained an appropriate endorsements as provided in this **Subparagraph 14.3.7**.

**14.3.9 [RESERVED]**

**14.3.10 [RESERVED]**

**14.3.11** Partial use shall not commence until the insurance company or companies providing property insurance have consented to such partial use by endorsement or otherwise. The Authority and the Trade Contractor shall take reasonable steps to obtain consent of the insurance company or companies and shall, without mutual written consent, take no action with respect to partial occupancy or use that would cause cancellation, lapse of reduction of insurance.

**14.3.12** Any deductibles required to be paid for Claims made by the Trade Contractor or Subcontractors shall be paid by the claiming Trade Contractor or claiming Subcontractor.

**14.4 Bonds**

**14.4.1** Pursuant to Minnesota Statutes §§ 574.26 - 574.32 and the Act, the Trade Contractor is required to provide a Payment Bond and a Performance Bond each in an amount equal to one-hundred percent (100%) of the Trade Contract Amount and in the form of **Exhibit 7** hereto and from a surety or sureties acceptable to the Authority. If after the giving of the bonds the Trade Contract Amount is increased, for any reason, the Authority may require additional bonds, the amount of which shall be not less than the amount of the increase in the Trade Contract Amount, and if the additional bonds are

not furnished within ten (10) Days after demand, the Trade Contractor Work shall cease until the additional bonds are furnished.

**14.4.2** The Payment Bond and Performance Bond shall each comply with the following specific requirements:

- .1** [RESERVED]
- .2** Bonds shall be executed by a responsible surety licensed and authorized to do business in the State of Minnesota, with a Best's Key Rating Guide's rating of no less than A:X and shall remain in effect for a period not less than one (1) year following the date of Substantial Completion or the time required to resolve any items of incomplete Trade Contractor Work and the payment of any disputed amounts, whichever time period is longer;
- .3** The Performance Bond and the Labor and Material Payment Bond shall each be in an amount equal to the Trade Contract Amount and the Performance Bond shall guarantee Trade Contractor will satisfactorily perform each and every part of the Trade Contractor Work, including all guarantees and warranties required;
- .4** Late completion shall be considered a failure of performance and any liquidated damages owed by the Trade Contractor as a result of late completion shall be covered by Trade Contractor's performance bond; and
- .5** Every Bond under this **Subparagraph 14.4.3** must display the Surety's Bond Number. A rider including the following provisions shall be attached to each Bond:

"Surety hereby agrees that it consents to and waives notice of any addition, alteration, omission, change, or other Modification of the Trade Contract Documents which, singularly or in the aggregate, does not exceed One Hundred Fifty Percent (150%) of the Trade Contract Amount. Except as to increases in the Trade Contract Amount in excess of the percentage set for the above in this **Subparagraph 14.4.3.5.1**, any other addition, alteration, change, extension of time, or other Modification of the Trade Contract Documents, or a forbearance on the part of the Authority or the Trade Contractor to each other, shall not release the Surety of its obligations hereunder and notice to the Surety of such matters is hereby waived.

Surety further agrees that in event of any default by the Authority in the performance of the Authority's obligations under the Trade Contract Agreement, the Trade Contractor or Surety shall cause written notice of such default, specifying said default in detail, to be given to the Authority, and the Authority shall have thirty (30) Days after the receipt of such notice within which to cure such default, or such additional reasonable period of time as may be required if the nature of such default is such that it cannot be cured within thirty (30) Days. Such Notice of Default shall be sent by certified or registered U.S. Mail, return receipt requested, first class postage prepaid, to the Authority.

Surety agrees that it is obligated under the bonds to the Authority and to any successor, grantee or assignee of the Authority."

**14.4.3** The costs of all bonds required under this **Paragraph 14.4** shall be included in the Trade Contract Amount.

**14.4.4** In any Claim involving the surety and the Trade Contractor, the surety shall be bound by and agrees to be a Party to the dispute resolution provisions in **Paragraph 6.2 – 6.4** of this Trade Contract Agreement, including arbitration.

## **14.5 General Insurance Requirements**

**14.5.1** All insurance coverages required under this **Paragraph 14** shall be provided by insurance companies having policyholder ratings no lower than "A" and financial ratings not lower than "X" in the Best's Key Rating Guide, latest edition in effect as of the date of the respective contracts contemplated hereunder, and subsequently in effect at the time of renewal of any policies required by the Trade Contract Documents.

**14.5.2** If the Authority or any Indemnitee is damaged by the failure of any other party to purchase or maintain insurance required under this **Paragraph 13**, then the party required to obtain or maintain, or to cause to be obtained or maintained, the insurance shall bear all damages and costs, including attorneys' fees and court and settlement expenses, attributable thereto.

**14.5.3 - .4 [RESERVED]**

**14.5.5** If any insurance required herein is to be issued or renewed on a claim-made form as opposed to the occurrence form, the retroactive date for coverage will be no later than the commencement date of the Trade Contractor Work and will state that in the event of cancellation or nonrenewal, the discovery period for insurance claims (tail coverage) will be at least sixty (60) months.



**14.5.6** All policies, except for the Professional Liability Policy, and Workers Compensation policies (if such waivers are not available), shall be endorsed to provide a waiver of subrogation in favor of the Authority and Indemnitees.

**15. Uncovering and Correction of Trade Contractor Work.**

**15.1 Uncovering of Work.** If a portion of the Trade Contractor Work is covered contrary to the Authority's request or needs to be inspected by any Governmental Authority, it will be uncovered for their observation, and be replaced at the Trade Contractor's expense without change in the Contract Time or the Trade Contract Amount. If a portion of the Trade Contractor Work has been covered which the Authority has not specifically requested to observe prior to its being covered, the Authority may request to see such Trade Contractor Work and it shall be uncovered by the Trade Contractor. If such Trade Contractor Work is in accordance with the Trade Contract Documents, costs of uncovering and replacement shall, by appropriate Contract Revision, be charged to the Authority. If such Trade Contractor Work is not in accordance with the Trade Contract Documents, the Trade Contractor shall pay such costs.

**15.2 Correction of Trade Contractor Work**

**15.2.1** The Trade Contractor shall promptly correct Trade Contractor Work rejected by the Authority for failing to conform to the requirements of the Trade Contract Documents, whether observed before or after Substantial Completion and whether or not fabricated, installed or completed. The Trade Contractor shall bear all costs of correcting such rejected Trade Contractor Work, including additional Testing and inspections and compensation for the Authority's or a Consultant's services and expenses made necessary thereby and such costs shall not be considered allowable. If prior to the date of Substantial Completion, the Trade Contractor, a Subcontractor, or anyone for whom either is responsible uses or damages any portion of the Trade Contractor Work, including, without limitation, mechanical, electrical, plumbing, or other building systems, machinery, or equipment, the Trade Contractor shall cause such item to be restored to "like new" condition.

**15.2.2** Within one (1) year after the date of Substantial Completion of the Trade Contractor Work or designated portion thereof, or after the date for commencement of warranties, or by terms of an applicable special warranty required by the Trade Contract Agreement, if any of the Trade Contractor Work is found to be not in accordance with the requirements of the Trade Contract Agreement, the Trade Contractor shall correct it promptly after receipt of written notice from the Authority to do so unless the Authority has previously given the Trade Contractor a written acceptance of such condition. This period of one (1) year shall be extended with respect to portions of Trade Contractor Work first performed after Final Completion by the period of time between Final Completion and the actual performance of the Trade

Contractor Work. This obligation under this **Subparagraph 15.2.2** shall survive Final Completion and acceptance of the Trade Contractor Work under the Agreement and termination of the Agreement. The Authority shall provide such notice promptly after discovery of the improper conditions.

**15.2.3** If the Trade Contractor fails to correct nonconforming Trade Contractor Work within a reasonable time, the Authority may correct it. If the Trade Contractor does not proceed with correction of such nonconforming Trade Contractor Work within a reasonable time fixed by written notice from the Authority, the Authority may remove it and store the salvageable materials or equipment at the Trade Contractor's expense. If the Trade Contractor does not pay costs of such removal and storage within ten (10) Days after written notice, the Authority may upon ten (10) additional Days' written notice sell such materials and equipment at auction or at private sale and shall account for the proceeds thereof, after deducting costs and damages that should have been borne by the Trade Contractor, including compensation for the Architect's and the Consultant's services and expenses made necessary thereby. If such proceeds of sale do not cover costs that the Trade Contractor should have borne, the Trade Contract Amount shall be reduced by the deficiency. If payments then or thereafter due the Trade Contractor are not sufficient to cover such amount, the Trade Contractor shall pay the difference to the Authority.

**15.2.4** The Trade Contractor shall be responsible for all reasonable and direct costs of the Authority resulting from corrections in the Trade Contractor Work for which Trade Contractor is responsible and shall be further responsible for any Design Services which are caused or necessitated by errors, omissions, inconsistencies or other damages caused by the Trade Contractor and for which the Trade Contractor is responsible.

**15.2.5** Nothing contained in this **Paragraph 15.2** shall be construed to establish a period of limitation with respect to other obligations that the Trade Contractor might have under the Trade Contract Agreement. Establishment of the time period of one (1) year as described in **Subparagraph 15.2.2** relates only to the specific obligation of the Trade Contractor to correct Trade Contractor Work, and has no relationship to the time within which the obligation of the Trade Contractor to comply with the Trade Contract Agreement may be sought to be enforced, nor to the time within which proceedings may be commenced to establish the Trade Contractor's liability with respect to the Trade Contractor's obligations other than specifically to correct its Trade Contractor Work.

## **16. Termination or Suspension by Authority**

**16.1 Termination or Completion of the Trade Contractor Work by the Authority for Cause.** If the Trade Contractor defaults or neglects to carry out the Trade Contractor Work in accordance with this Trade Contract Agreement and fails, in the reasonable determination of the Authority, within a seven (7) Day period after receipt of written notice from the Authority to commence and continue correction of such default or neglect with diligence and promptness, the Authority may, without prejudice to other remedies the Authority may have, terminate this Trade Contract Agreement and commence and continue to carry out the Trade Contractor Work or terminate the Trade Contractor Work. The right of the Authority to terminate this Trade Contract Agreement shall not give rise to any duty on the part of the Authority to exercise this right for the benefit of the Trade Contractor.

**16.2 Suspension or Termination by the Authority for Convenience.** The Authority may, in its sole discretion and at any time, suspend or terminate this Trade Contract Agreement for the Authority's convenience and without cause.

**16.2.1** Upon receipt of written notice from the Authority of such suspension or termination for the Authority's convenience, the Trade Contractor shall:

- .1** cease operations as directed by the Authority in the notice;
- .2** take actions necessary, or that the Authority may direct, for the protection and preservation of the Trade Contractor Work; and
- .3** except for Trade Contractor Work directed to be performed prior to the effective date of suspension or termination stated in the notice, suspend or terminate all existing Subcontracts and purchase orders and enter into no further Subcontracts and purchase orders.

**16.2.2** In case of such termination for the Authority's convenience, the Trade Contractor shall recover, as its sole remedy, payment for the Trade Contractor Work properly performed prior to the effective date of termination and for equipment ordered and not returnable, and proven costs of termination for the Trade Contractor such as, for example, restocking charges, non-cancelable material purchase orders, and attributable to the Trade Contractor Work actually executed. The Trade Contractor hereby waives and releases all other Claims for payment and damages, including anticipated fees, profits or lost overhead for portions of the unperformed Trade Contractor Work. The Authority shall be credited for:

- .1** payments previously made to the Trade Contractor for the terminated portion of the Trade Contractor Work;

- .2 Claims that the Authority has against the Trade Contractor under this Trade Contract Agreement; and
- .3 the value of the materials, supplies, equipment, or other items that are to be disposed of by the Trade Contractor that are part of the Trade Contract Amount.

## 17. General Provisions

**17.1 Nondiscrimination.** In connection with the performance of its Trade Contractor Work, the Trade Contractor agrees not to illegally discriminate against any employee or applicant for employment for any reason, including: age, race, sex, national origin, ancestry, religion, or color. This provision shall include the following: employment, upgrading, demotion or transfer, recruitment or recruitment advertising, layoff or termination, rates of pay or other forms of compensation, and selection for training.

**17.2 Successors and Assigns.** The Authority and Trade Contractor each bind themselves, their partners, successors, permitted assigns, and legal representatives to the other Party to this Trade Contract Agreement and to the partners, successors, permitted assigns, and legal representative of such other Party with respect to covenants of this Trade Contract Agreement. Notwithstanding anything to the contrary in this Trade Contract Agreement, it is acknowledged and agreed that the Authority shall have the right to assign all its rights and duties under this Trade Contract Agreement without the consent of Trade Contractor to third parties, including the Team and the Construction Manager. The Trade Contractor shall execute all consents reasonably required to facilitate such assignment, provided, such assignment by the Authority shall not relieve the Authority of its obligations under this Trade Contract Agreement unless Trade Contractor agrees to a novation of the same. This Trade Contract Agreement may not be assigned by Trade Contractor without the prior written approval of the Authority, which approval may be withheld in the Authority's sole discretion.

**17.3 Inspection.** Inspection of the progress, quantity, or quality of the Trade Contractor Work done by the Authority, any Authority representative, any Governmental Agency, the Architect, or any inspector, shall not relieve the Trade Contractor of any responsibility for the compliance of the Trade Contractor Work with the Trade Contract Documents. The Authority or its approved representative shall have access to the work site and all Trade Contractor Work. No supervision or inspection by the Authority's representative, nor right of the Authority to act, nor any other actions taken by the Authority's representative shall relieve the Trade Contractor of any of its obligations under the Trade Contract Documents nor give rise to any duty on the part of the Authority. If any of the Trade Contractor Work is required to be inspected or approved by any Governmental Authority, the Trade Contractor shall cause such inspection or approval to be performed. No inspection performed or failed to be performed by the Authority hereunder shall be a waiver of

any of the Trade Contractor's obligations hereunder or be construed as an approval or acceptance of the Trade Contractor Work or any part thereof.

**17.3.1** Notwithstanding **Paragraph 17.3**, the Authority will have the right to make specific elections and approve interim and final design elements, including but not limited to, the selection of equipment and the location of the equipment.

**17.4 Claims Against Others Involved With Project.** Should Trade Contractor have a Claim against a Person involved with the Project, who is not the Authority or an Indemnitee, then the Trade Contractor shall make such Claim directly against such other Person and not against the Authority or any of the Indemnitees.

**17.5 Cost Overruns.** Trade Contractor agrees and acknowledges that the Act requires the Authority to procure project construction in a manner that any cost overruns are the responsibility of the proposer and not the Authority or the State. Accordingly, Trade Contractor agrees and acknowledges that as the successful proposer, Trade Contractor is solely responsible for any cost overruns that may occur on the Project as may apply to the Trade Contractor Work in excess of the Trade Contract Amount as modified in accordance with and as allowed by the Trade Contract Documents, however caused, as the Authority has no authority to accept liability for cost overruns in contravention of the Act.

**17.6 Governing Law, Venue, and Jurisdiction.** The laws of the State of Minnesota, without giving any effect to conflicts of law provisions, shall govern and construe this Trade Contract Agreement. Each Party to this Trade Contract Agreement (a) agrees that except for those Claims or disputes which are subject to dispute resolution requirements set forth in **Paragraphs 6.2 to 6.4** of this Trade Contract Agreement, any suit, action, or other legal proceeding arising out of the Trade Contractor Work, this Trade Contract Agreement, any related agreements, or any of the transactions contemplated hereby or thereby shall be brought in the courts of the State of Minnesota, Fourth Judicial District, Hennepin County District Court; (b) consents to the jurisdiction of such court in any such suit, action, or proceeding; and (c) waives any objection which it may have to the venue of any such suit, action, or proceeding in such court.

**17.7 Project Labor Agreement.** The Trade Contractor has reviewed and agrees to comply with the Project Labor Agreement for the Project which is available on the Authority's website at:

[http://www.msfa.com/detail.cfm/page/msfaSite\\_IYVNFTSJ\\_GJZVWBGJ/](http://www.msfa.com/detail.cfm/page/msfaSite_IYVNFTSJ_GJZVWBGJ/).

**17.8 Warranty.**

**17.8.1** The Trade Contractor warrants to the Authority that the Trade Contractor Work will be of good quality and new unless otherwise required or permitted by the Trade Contract Documents, that the Trade Contractor Work will be free from defects. The Trade Contractor represents and warrants to

the Authority that its design and materials and workmanship, including its construction means, methods, procedures, and techniques necessary to perform the Trade Contractor Work, and its use of materials, selection of equipment, and requirements of product manufacturers are and shall be consistent with: (a) good and sound practices within the construction industry; (b) generally prevailing and accepted industry standards applicable to the Trade Contractor Work; (c) requirements of any warranties applicable to the Trade Contractor Work; and (d) all Applicable Laws. Trade Contractor Work not conforming to these requirements, including Substitutions not properly approved and authorized, shall be considered defective, and promptly after notification of non-conformance shall be repaired or replaced by Trade Contractor with Trade Contractor Work conforming to this warranty. The Trade Contractor's warranty excludes remedy for damage or defect caused by normal wear and tear under normal usage. If required by the Authority, the Trade Contractor shall furnish satisfactory evidence as to the kind and quality of materials and equipment.

**17.8.2** Trade Contractor further warrants that all materials that affect the aesthetics of finishes or equipment of a category or classification will be a product of the same manufacturer and such materials or equipment shall be of the same lot, batch, or type.

**17.9 Notice Provisions.** Every notice, demand, request, consent, approval, or other communication, including notice of breach, indemnity, suspension, termination, or default, that either the Trade Contractor or Authority is required or desires to give or make to the other Party hereto shall, notwithstanding any other provisions of this Trade Contract Agreement, be effective only if given in writing and delivered by hand and receipted for, or by registered or certified mail, postage-prepaid, return receipt requested, or by overnight mail as follows:

**17.9.1** If to the Construction Manager, addressed to:

[insert]

**17.9.2** If to the Authority, addressed to:

Minnesota Sports Facilities Authority  
1005 South 4<sup>th</sup> Street  
Minneapolis, MN 55415  
Attention: Executive Director  
Fax: 612-332-8334

with a copy to: Dorsey & Whitney, LLP  
Suite 1500  
50 South Sixth Street  
Minneapolis, MN 55402-1498  
Attention: Jay R. Lindgren  
Fax: 612-340-2868

with a copy to: Fabyanske, Westra, Hart & Thomson, PA  
333 South Seventh Street, Suite 2600  
Minneapolis, MN 55402  
Attention: Dean B. Thomson  
Fax: 612-359-7602

with a copy to: Minnesota Vikings Football, LLC  
9520 Viking Drive  
Eden Prairie, MN 55344  
Attention: Kevin Warren  
Chief Operating Officer  
Fax: 952-828-6513

Minnesota Vikings Football, LLC  
9520 Viking Drive  
Eden Prairie, MN 55344  
Attention: Steve Poppen  
Chief Financial Officer  
Fax: 952-828-6514

with a copy to: Briggs and Morgan, P.A.  
2200 IDS Center  
80 South Eighth Street  
Minneapolis, MN 55402  
Attention: Mike Grimes and  
Matt Slaven  
Fax: 612-977-8650

with a copy to: Garden Homes Development  
820 Morris Turnpike  
Short Hills, NJ 07078  
Attention: Donald Becker  
Stadium Project Executive

**17.9.3** If to the Trade Contractor, addressed to:

**[insert]**

Or to such other address or addresses or via other means as Authority and Trade Contractor shall from time to time designate by written agreement and notice given and delivered as aforesaid.

**17.10 Public Project.** The Parties agree and acknowledge that the Project is a public project and the Project will be used for public purposes and all of the Trade Contractor Work hereunder is in furtherance of a public project.

**17.11 Prevailing Wages.** The Trade Contractor shall pay the prevailing wage rates, prevailing hours of labor, and hourly basic rates of pay determined for this Project, and will incorporate into this Trade Contract Agreement the applicable wage determinations for Trade Contractor Work along with language from the commissioner of the state Department of Labor and Industry that will notify the Trade Contractor and its Subcontractors of the applicability of Minn. Stat. §§ 177.41 to 177.44 to this Project. The Trade Contractor shall comply with prevailing wage requirements under Minn. Stat. §§ 177.41 to 177.43 or as otherwise required by the Trade Contract Documents or Applicable Laws. The Authority shall demand and the Trade Contractor and its Subcontractors shall furnish to the Authority copies of any or all payrolls no more than fourteen (14) Days after the end of each pay period and said payrolls must contain all the data required by Minn. Stat. § 177.30. Trade Contractor shall also utilize the LCPtracker online labor tracking report at the request of the Authority. The Authority may also examine all records relating to wages paid to laborers or mechanics on work to which Minn. Stat. §§ 177.41 to 177.43 apply.

**17.12 Confidentiality**

**17.12.1**The Trade Contractor shall keep strictly confidential all Confidential Information concerning and relating to the Trade Contract Agreement and the Project. The Trade Contractor, its officers, agents, owners, partners, employees, volunteers, and Subcontractors shall abide by the provisions of the Minnesota Government Data Practices Act, Minnesota Statutes, ch. 13 (the “MGDPA”) and all other Applicable Laws relating to data privacy or confidentiality, and as any of the same may be amended. The Trade Contractor agrees to defend, indemnify, and hold harmless the Indemnitees from and against any claims resulting from the unlawful disclosure and/or use of such protected data by the Trade Contractor or the officers, agents, owners, partners, employees, volunteers, assignees, or Subcontractors of the Trade Contractor, or other noncompliance with the requirements of this **Subparagraph 17.12.** The Trade Contractor agrees to promptly notify the Authority and Team if it becomes aware of any potential claims, or facts giving rise to such, under the MGDPA.

**17.12.2**As a result of the Trade Contractor and all other members of the Project Team’s participation in the Project, the Project Team will have access to information and materials of a highly sensitive nature, including



Confidential Information belonging to the Authority or the Team. The Trade Contractor, hereby warrants that its employees, Subcontractors, and agents shall not (without in each instance obtaining prior written consent of the other party) disclose, make commercial or other use of, or give or sell to any Person, firm, or corporation, any Confidential Information received directly or indirectly from the Authority or the Team, as applicable, or acquired or developed in the course of the performance of the Trade Contractor Work unless: (a) required to do so pursuant to Applicable Laws (and then only after the Trade Contractor or other member of the Project Team has given the Authority or the Team, as applicable, prompt written notice of the legal compulsion and, at the Authority's or the Team's, as applicable, expense, provide the Authority or the Team, as applicable, with cooperation in any attempt the Authority or the Team, as applicable, may make to gain a protective order acceptable to the Authority or the Team, as applicable); or (b) it is rightfully in the possession of the Trade Contractor or other Project Team member from a source other than the Authority or the Team prior to the time of disclosure of the information to the Trade Contractor or other Project Team member under the Trade Contract Documents; or (c) it became part of the public domain prior to the time of the Trade Contractor's or other Project Team member's receipt; or (d) it is supplied to the Trade Contractor or other Project Team member after the time of the Trade Contractor's or other Project Team members receipt by a third-party who is under no obligation to the Authority or to the Team to maintain such information in confidence; or (e) it was independently developed by the Trade Contractor or other Project Team member prior to the time of receipt.

**17.12.3**The Trade Contractor's or other Project Team members' confidentiality and non-disclosure obligations shall survive the expiration or earlier termination of their respective agreements and shall continue for a period of seven (7) years following the expiration or earlier termination of their respective agreements. All Confidential Information, regardless of form, shall be the property of the Authority or Team, as applicable, and shall be returned to the Authority or Team upon its request, or in any event, at the expiration or earlier termination of the Trade Contract Agreement.

### **17.13 Trade Secrets, Trademarks and Trade Names**

**17.13.1**The Trade Contractor, and Project Team acknowledge that the Authority or Team may provide the Trade Contractor and Project Team with access to certain information which may qualify as a Trade Secret under Applicable Laws, and the Trade Contractor and Project Team agree that for all such Trade Secrets that come into their possession, custody or control: (a) such Trade Secrets shall remain the sole property of the Authority or Team, as applicable, and the Architect, Trade Contractor, and Project Team shall have no interest in said Trade Secrets; (b) the Trade Contractor and Project Team shall maintain the secrecy of the Trade Secrets for so long as they

remain Trade Secrets under Applicable Laws; and (c) immediately upon the expiration or earlier termination of the Project, the Trade Contractor and Project Team shall deliver to the Authority or Team, as applicable, all Trade Secret documentation and any and all copies thereof, regardless of form or content.

**17.13.2** Without prior written approval of the Authority or Team, as applicable, the Trade Contractor and Project Team shall have no right to use any Trademark or Trade Name of the Authority, Team, or Affiliated Entities. Further, the Trade Contractor and Project Team shall not refer to the Trade Contract Documents or the Trade Contractor Work performed thereunder or to any Confidential Information, directly or indirectly, in connection with any production, promotion, or publication without the prior written consent of the Authority and Team, and the Authority and Team reserve the right in their sole discretion to release such information, time its release, and approve its form and content prior to release.

**17.13.3** The Trade Contractor and Project Team may publish information (other than Trade Secrets and Confidential Information, which shall not be published) and images resulting from or relating to the Trade Contractor Work only after obtaining the Authority's and Team's prior written approval, which Authority and Team may grant or withhold in their sole discretion. The Authority and Team's approval, if granted, may be conditioned upon changes in the text, the use of different images, or reasonable delay in publication to protect Trade Secrets or Confidential Information and other interests of the Authority or Team.

#### **17.14 Press Releases and Other Promotional Materials**

**17.14.1** Both prior to, during, and after completion of the Project, the Authority and Team shall control the issuance of all press releases and all contacts with the press and all other media relating to the Project. The Trade Contractor and Project Team may not issue any press release, agree to be interviewed by members of the press, or otherwise interact with and/or disseminate information to the press or any media without the prior written consent of the Authority and Team, which consent may be withheld by the Authority and Team in their sole discretion.

**17.14.2** After completion of the Project, the Trade Contractor and Project Team may use images of the Project and explanatory text in the Trade Contractor's and Project Team member's marketing and promotional materials, subject to the Authority's and the Team's written approval prior to the Trade Contractor's or Project Team member's first use of such materials; provided, however, that the Trade Contractor's and Project Team member's marketing and promotional materials should not include any of the Authority's or the Team's Confidential Information.

**17.14.3** No signs advertising the services to be performed by the Architect, Trade Contractor, or Project Team, or identifying any Person, firm or entity concerned with the Trade Contractor Work to be performed by the Architect, Trade Contractor, or Project Team shall be allowed at the Project Site or elsewhere unless approved in writing by the Authority and the Team in advance, which approval shall be within Authority's and the Team's sole and exclusive discretion.

**17.15 Ownership and Use of Architect's Drawings, Specifications and Other Documents**

**17.15.1** The Drawings, Specifications and other documents prepared by the Architect are instruments of the Architect's service through which the Trade Contractor Work to be executed by the Trade Contractor is described and are the property of the Authority. The Trade Contractor or any Subcontractor, Sub-Subcontractor, Supplier, Trade Contractor, Vendor, or Consultant shall not own or claim a copyright in the Drawings, Specifications and other documents prepared by the Architect. The Authority will retain all common law, statutory and other reserved rights, in addition to the copyright. The Drawings, Specifications and other documents prepared by the Architect, and copies thereof furnished to the Trade Contractor or any Subcontractor, Sub-Subcontractor, Supplier, Trade Contractor, Vendor, or Consultant, are for use solely with respect to this Project. They are not to be used by the Trade Contractor or any Subcontractor, Sub-Subcontractor or Supplier, Trade Contractor, Vendor, or Consultant on other projects or for additions to this Project outside the scope of the Trade Contractor Work without the specific written consent of the Authority. The Trade Contractor, Subcontractors, Sub-Subcontractors, Suppliers, Trade Contractor, Vendors, or Consultant are granted a limited license to use and reproduce applicable portions of the Drawings, Specifications and other documents prepared by the Architect appropriate to and for use in the execution of their Trade Contractor Work. Submittal or distribution to meet official regulatory requirements or for other purposes in connection with this Project is not to be construed as publication in derogation of the Authority's copyright or other reserved rights.

**17.16 Third-Party Beneficiaries.** Nothing contained in this Trade Contract Agreement shall create or is intended to create a contractual relationship with, or a cause of action in favor of, any third-party against the Authority or any of the Indemnitees. Notwithstanding the foregoing, the Parties hereto acknowledge and agree to the third-party beneficiary rights established in **Paragraph 17.18** herein.

**17.17 Independent Contractor.** The Trade Contractor expressly acknowledges that it is an independent contractor and that it is not the representative or agent of the Authority or Team. Nothing contained in this Trade Contract Agreement shall be construed as constituting a joint venture or partnership

between the Trade Contractor and the Authority or the Team. The Trade Contractor shall have no authority to act on behalf of the Authority. Under no circumstances shall Trade Contractor contract, negotiate or make commitments concerning the Project with any Governmental Authority or other authority with jurisdiction over the Project without the Authority's prior written authorization.

**17.18 Third-Party Beneficiaries.** It is expressly agreed and understood that all of the Indemnitees are intended third-party beneficiaries of all the representations, warranties and covenants made by the Trade Contractor in the Trade Contract Documents, including without limitation the promises of the Trade Contractor to perform and complete the Trade Contractor Work. The rights of third-party beneficiaries as described herein shall be consistent with the Trade Contract Documents. The responsibilities and liabilities of the Trade Contractor toward such third-party beneficiaries shall be consistent with the Trade Contract Documents.

**18. Entire Agreement**

**18.1** This Trade Contract Agreement represents the entire agreement between the Authority and Trade Contractor and supersedes any prior negotiations, representations, promises, or agreements whether written or oral. This Trade Contract Agreement may be amended only by written instrument signed by both Authority and the Trade Contractor.

[THIS SPACE LEFT INTENTIONALLY BLANK]

[SIGNATURE PAGE FOLLOWS]

**THIS TRADE CONTRACT AGREEMENT** is entered into as of the day and year first written above.

**AUTHORITY:**

---

By:  
Title: Its Chair

**AUTHORITY:**

---

By:  
Title: Its Executive Director

**TRADE CONTRACTOR:**

---

By: \_\_\_\_\_

Title: \_\_\_\_\_

**DEFINED TERMS OF BE USED IN THE TERMS OF DESIGN AND CONSTRUCTION**  
**APPENDIX A**

**DEFINITIONS**

Defined terms as used in the Trade Contract Documents shall have the following meanings:

**“Act”** shall mean 2012 Minnesota Laws, Chapter 299, as enacted or hereafter amended or supplemented, and including any successor law, providing for, among other things, the construction, financing, operation, and long-term use of a multi-purpose stadium and related infrastructure as a venue for the National Football League and a broad range of other civic, community, athletic, educational, cultural, and commercial activities in the City of Minneapolis, Minnesota.

**“Additional Insured Parties”** shall have the meaning set forth in **Subparagraph 9.1.15** of the Design Services Agreement.

**“Adjacent Property”** shall mean all land adjoining and surrounding the Stadium Site on which will be located any public streets, sidewalks, plazas, or bridges and any public or private parking facilities or other accoutrements to be developed by Authority or other parties in connection with the Project.

**“Affiliate” or “Affiliated Entity”** of a specified Person shall mean any entity, corporation, partnership, limited liability company, sole proprietorship or other Person that directly or indirectly, through one or more intermediaries controls, is controlled by, or is under common control with the Person specified. For purposes of the Trade Contract Agreement, the terms “controls,” “controlled by,” or “under common control” means the possession, direct or indirect, of the power to direct or cause the direction of the management and policies of a Person.

**“Alternate”** shall mean a proposed possible change in the Trade Contractor Work as described in the Trade Contract Documents.

**“Applicable Laws”** shall mean any and all laws (including all statutory enactments and common law), constitutions, treaties, statutes, codes, ordinances, charters, resolutions, Orders, rules, regulations, guidelines, standards, Governmental Approvals, authorizations, or other directives or requirements of any Governmental Authority enacted, adopted, promulgated, entered, implemented, ordered or issued and in force or deemed applicable by or under the authority of any Governmental Authority having jurisdiction over a Person (or the property of such Person), including the Act and Environmental Laws, applicable to the State, County, City, Authority, Team, Architect, Construction Manager, Trade Contractor, and/or other applicable Persons in connection with the design, development, construction, equipping, commissioning, use, occupancy, possession, operation, maintenance and management of the Project. Notwithstanding the foregoing, Applicable Laws shall expressly include all requirements, regulations and administrative orders of the City, County and State, as same may be modified by variances and waivers issued in accordance with Applicable Laws.

**“Application for Payment”** shall mean the Trade Contractor’s monthly requisition for payment, if any, which shall be submitted on the form provided by the Authority.

**“Architect”** such firm of licensed architects and/or engineers as may be designated by Authority from time to time. For the purpose of the Trade Contract Agreement and the Trade Contract Documents, the Trade Contractor shall be deemed the Architect of any design/build Trade Contractor Work to be performed hereunder.

**“As-Built Drawings”** shall mean CAD generated red-lined Construction Documents showing the Trade Contractor Work as constructed, prepared by the Trade Contractor and indicating actual locations of utilities and all changes and alterations made to the Trade Contractor Work during construction. CAD files will be provided by the Trade Contractor in a format acceptable to the Authority.

**“Authority”** shall mean the Minnesota Sports Facilities Authority, a public body and political subdivision of the State of Minnesota, and its successors, assigns and designees.

**“Business Day”** or **“Work Day”** shall mean Monday, Tuesday, Wednesday, Thursday and Friday, excluding any day that banks are required to close in the State of Minnesota, and excluding Saturday and Sunday.

**“Certificate for Payment”** shall mean a written certificate executed by the Authority indicating the amount that the Trade Contractor is entitled to be paid in connection with each Trade Contractor Application for Payment.

**“Change”** shall mean an agreed-upon and materially significant Modification to the size, quality, or complexity of the Trade Contractor Work recognized and allowed by the Trade Contract Agreement that also affects the Trade Contract Amount and Contract Time.

**“Change Order”** shall mean a written order signed by the Trade Contractor, authorizing a change in a Subcontractor’s scope of Work.

**“City”** shall mean the City of Minneapolis, Minnesota.

**“Claim”** shall have the meaning set forth in **Subparagraph 6.2.1** of this Trade Contract Agreement.

**“Conceptual Design Documents”** shall mean the preliminary project work plan, programming report and pre-design documents, concept sketches and renderings illustrating the scale and relationship to the components of the Trade Contractor Work.

**“Confidential Information”** shall mean all Trade Secrets and other information (whether or not specifically labeled or identified as confidential), in any form or medium, which is disclosed to or learned by the Trade Contractor and/or the Trade Contractor’s Subconsultants, the Construction Manager and/or the Construction Manager’s Subcontractors, Trade Contractors or any other member of the Project Team in the performance of the Trade Contractor Work required in the Trade Contract Documents, or

acquired directly or indirectly such as in the course of discussion or investigations by the Trade Contractor and the Trade Contractor's Subconsultants relating to the Project, and which relates to the Authority or Team's business, finances, marketing strategy, products, services, research or development, suppliers, clients, or customers, or which relates to similar information of a third-party who has entrusted such information to the Authority including, without limitation, any specialized know-how, technical or non-technical data, formula, pattern, plan, strategy, compilation, program, device, method, technique, drawing, process, financial or business information, models, novel analysis, work papers, studies or other documents that contain, reflect, or are based on such information.

**"Construction Change Directive"** shall have the meaning ascribed in **Paragraph 7.3** of the Trade Contract Agreement.

**"Construction Documents"** shall mean those deliverables to be provided by the Trade Contractor, which are necessary to complete the Trade Contractor's Work, including, but not limited to, the Drawings and Specifications.

**"Construction Documents Phase"** shall mean that Phase during which the Construction Documents are being prepared by the Trade Contractor.

**"Construction Manager"** shall mean any person or legal entity with whom the Authority has contracted to serve as contract manager, project manager, and/or construction manager for the work work covered by this Trade Contract Agreement.

**"Construction Phase"** shall mean that Phase of the Project which shall commence after the Authority provides the Trade Contractor with written Notice to Proceed with the Construction Phase.

**"Construction Schedule"** shall mean the schedule prepared by a Trade Contractor and approved by the Authority, and all adjustments thereto approved by the Authority, that describes the sequence and timing of the Trade Contractor Work on the Project.

**"Consultant"** shall mean a Person engaged by the Authority, Team or Trade Contractor to perform a portion of the professional services associated with the Project under direct contract with the Authority, Team or Trade Contractor.

**"Consultant's Services"** shall mean the complete professional services to be provided by the Consultant and as described in a Consulting Services Agreement between the Authority, the Team or Trade Contractor and the Consultant, and includes all labor, materials, equipment and services to be provided by the Consultant to fulfill its obligations.

**"Consulting Services Agreement"** shall mean a contract between the Authority, the Team or Trade Contractor and a Consultant for the performance of professional services associated with the Project.

**"Contamination"** means the presence or release or threat of release of Regulated Substances in, on, under or emanating to or from the Stadium Site, which pursuant to Environmental



Laws requires notification or reporting to any Governmental Authority, or which pursuant to Environmental Laws requires the identification, investigation, cleanup, removal, remediation, containment, control, abatement, monitoring of or other Response Action to such Regulated Substances or which otherwise constitutes a violation of Environmental Laws.

**“Contract Request Form”** shall mean a form on which changes to the Trade Contractor Work or Contract Time are requested or on which approvals to use certain Subcontractors are requested by the Trade Contractor.

**“Contract Revision”** shall mean a written instrument prepared by the Authority and signed by the Authority and Trade Contractor stating their agreement upon a change in the Trade Contractor’s Work; the amount of the adjustment in the Trade Contract Agreement, if any; the extent of the adjustment in the Contract Time, if any, and the updated Schedule of Values.

**“Contract Time”** shall be as provided in the Trade Contract Agreement. Adjustments to the Contract Time may include adjustments to the Milestone Dates, the required date of Substantial Completion, or the required date of Final Completion, as applicable and as allowed by the Trade Contract Agreement.

**“Coordination Drawings”** shall mean drawings prepared by Trade Contractor and its Subcontractors detailing the Trade Contractor Work and the coordination of Trade Contractor Work items among the Trade Contractor and various Subcontractors.

**“CPM”** shall mean a Critical Path method format to be used for the Construction Schedule.

**“Critical Path”** shall mean those Trade Contractor Work activities identified on the Construction Schedule which, if delayed, will cause a corresponding Delay in the Substantial Completion Date.

**“Day”** shall mean a calendar day, unless otherwise specifically designated.

**“Delay”** shall mean any delay or interruption in the progress of the Trade Contractor Work as anticipated on the approved Construction Schedule.

**“Design Development Documents”** shall mean the Drawings, Specifications and other documents prepared by the Trade Contractor that establish and describe the size and character of the Trade Contractor Work as to architectural, civil, structural, mechanical and electrical systems, graphics and signage, and other elements, and which include typical construction details, equipment layouts and specifications that identify major materials and systems.

**“Design Development Phase”** shall mean that Phase during which the Architect prepares the Design Development Documents.

**“Design Documents”** shall mean, collectively and as applicable, the Conceptual Design Documents, Schematic Design Documents, the Design Development Documents and the Construction Documents prepared by the Trade Contractor.

**“Design Phases”** shall mean those Phases which are preparatory to the physical construction of the Trade Contractor Work during which the Schematic Design Documents, Design Development Documents and Construction Documents are being prepared by the Architect.

**“Design Services”** shall mean the complete architectural design and engineering for the Trade Contractor Work, and includes all labor, materials, equipment and services to be provided by the Trade Contractor to fulfill its obligations under the Trade Contract Agreement. The Design Services shall include all of the labor, materials, equipment and services to be provided by the Subconsultants of any tier employed directly or indirectly by the Trade Contractor, and shall include all necessary and appropriate coordination and integration of the Consultant’s Services and Architect’s services to allow the Trade Contractor to complete the Trade Contractor Work in accordance with the Design Documents. The Design Services shall be performed in strict accordance with all provisions of the Act.

**“Design Services Agreement”** shall mean any Agreement between the Architect and the Authority for design of the Project.

**“Design Team”** shall mean Architect and its Subconsultants as set forth in the Design Services Agreement.

**“Drawings”** shall mean graphic or pictorial portions of the Design Documents prepared by Trade Contractor, Subconsultants, and Consultants, wherever located and whenever issued, which show, among other things, the design, location and dimensions of the Trade Contractor Work, generally including plans, elevations, sections, details, schedules and diagrams.

**“Electronic Data”** shall mean Design Documents and other Project, data transmitted in electronic format and as further defined in **Subparagraph 1.3.1** of the Design Services Agreement.

**“Environmental Laws”** shall mean all Applicable Laws, including any consent decrees, settlement agreements, judgments, or Orders, issued by, or entered into with, a Governmental Authority pertaining or relating to: (a) pollution or pollution control; (b) protection of human health or the environment; (c) the presence, use, management, generation, processing, treatment, recycling, transport, storage, collection, disposal or release or threat of release of Regulated Substances; (d) the presence of Contamination; and (e) the protection of endangered or threatened species.

**“Final Completion”** shall mean that the Trade Contractor has satisfactorily completed all of the Trade Contractor Work in strict conformity with the requirements of the Trade Contract Agreement, the Trade Contractor Work has been finally accepted by the Authority and the Trade Contractor’s submission of and the Authority’s approval of the Trade Contractor’s Final Application for Payment.

**“Final Payment”** shall mean the last payment to the Trade Contractor, including retainage, in connection with the Trade Contractor Work.

**“Force Majeure”** shall mean an act of God, fire, tornado, hurricane, named storms, flood, earthquake, explosion, war, terrorism, embargoes, civil disturbance, unusually severe weather that is abnormal and unforeseeable for the time of year in question or industry-wide strikes.

**“Governmental Approvals”** shall mean all waivers, franchises, variances, permits, authorizations, certificates, registrations, licenses, and Orders of and from any Governmental Authority having jurisdiction over the Project, Trade Contractor Work, Stadium Site, Adjacent Property, Authority, Team, Consultant, Architect, Subconsultant, Construction Manager, Subcontractor, Trade Contractor, Vendor City, County, State, and other applicable Persons in connection with the design, development, construction, equipping, commissioning, use, occupancy, possession, operation, maintenance and management of the Project or any Adjacent Property.

**“Governmental Authority(ies)”** shall mean any federal, state, county, municipal or other governmental department, entity, authority, commission, board, bureau, court, agency, or any instrumentality of any of them having jurisdiction with respect to the Project, Trade Contractor Work, Stadium Site, Adjacent Property, Authority, Team, Consultant, Architect, Subconsultant, Construction Manager, Subcontractor, Trade Contractor, Vendor, City, County, State, and other applicable Persons in connection with the design, development, construction, equipping, commissioning, use, occupancy, possession, operation, maintenance and management of the Project or any Adjacent Property.

**“Governmental Body”** or **“Governmental Bodies”** shall have the meaning set forth in **Paragraph 12.10** of the Design Services Agreement.

**“Guaranteed Completion Date”** shall have the meaning set forth in **Exhibit 6** of the Trade Contract Agreement.

**“Hazardous Materials”** shall mean: (a) any “hazardous waste” as defined by the Resource, Conservation and Recovery Act of 1976 (42 U.S.C. Section 6901, et seq.) as amended, and regulations promulgated thereunder; (b) any “hazardous, toxic or dangerous waste, substance or material” specifically defined as such in (or for the purposes of) the Comprehensive Environmental Response, Compensation and Liability Act of 1980 (42 U.S.C. Section 9601, et seq.), as amended, and regulations promulgated thereunder; (c) any “hazardous waste” or “hazardous substance” as defined by applicable Minnesota State laws and regulations), as amended, and regulations promulgated thereunder; and (d) any hazardous, toxic or dangerous waste, substance, or material as defined in any so-called “superfund” or “superlien” law or any other federal, state or local statute, law ordinance, code, rule, regulation, order or decree regulating, relating to or imposing liability or standards of conduct concerning such waste, substance or material.

**“Including”** shall encompass the phrase “including without limitation” and be understood to indicate an example and not a limitation.

**“Indemnitees”** shall mean the Minnesota Sports Facilities Authority, Minnesota Vikings Football, LLC, Minnesota Vikings Football Stadium, LLC, Hammes Company Sports Development, Inc., Architect, Construction Manager, Lender(s), their Affiliated Entities and each of the foregoing Persons’ elected officials, appointed officials, board members, directors, officers, shareholders, subsidiaries, parent companies, members, owners, agents, representatives, legal counsel, and employees, together with the constituent partners, members, owners, shareholders, and heirs and estates of each of the foregoing, and the City and State.

**“Knowledge”** The terms “knowledge,” “recognize” and “discover,” their respective derivatives and similar terms in the Trade Contractor Agreement, as used in reference to the Trade Contractor, shall be interpreted to mean that which the Trade Contractor knows, recognizes, or discovers or should have known, recognized, or discovered utilizing the Standard of Care applicable to the Trade Contractor. The expression “reasonably inferable” and similar terms in the Trade Contract Documents shall be interpreted by the Authority to mean reasonably inferable by the Trade Contractor.

**“Legal Requirements”** shall mean the requirements set forth in any Applicable Laws.

**“Lender”** shall mean any bank, insurance company, trust, corporation, association, firm, partnership, Person, or other entity that has loaned or agreed to lend or otherwise provide funds or credit enhancement to enable the development and construction of the Project.

**“Milestone Date”** shall mean a date in the Construction Schedule identified for its importance in measuring progress of all or part of the Trade Contractor Work.

**“Modification”** shall mean a writing changing the terms of a contract signed by the Parties to that contract.

**“National Football League”** or **“NFL”** shall mean, collectively, the Office of the National Football League Commissioner, the National Football League Commissioner, the member clubs of the National Football League, the NFL owners, and/or any other Person appointed by any of the foregoing, or any successor substitute association or entity of which the Team is a member or joint owner and which engages in professional football in a manner comparable to the National Football League.

**“NFL Rules and Regulations”** shall mean, collectively, the constitution and bylaws, and the rules, guidelines, regulations and requirements of the NFL, and any other rules, guidelines, directive, advisory opinions, regulations or requirements of the Office of the Commissioner of the NFL, and/or any other Person appointed by the foregoing, that are generally applicable to NFL franchises, all as the same now exist or may be amended or adopted in the future.

**“Order”** mean any judgment, award, decision, directive, consent decree, injunction (whether temporary, preliminary or permanent), ruling, or writ ordered adopted, enacted, implemented, promulgated, issued, entered or deemed applicable by or under the authority of any Governmental Authority or arbitrator that is binding on any Person or its property under Applicable Laws.

**“Party”** or **“Parties”** shall mean the Authority and/or the Trade Contractor as applicable.

**“Pending Change Report”** shall mean a summary of the status of all pending requests for Contract Revisions and Change Orders that the Authority may generate from time to time.

**“Person”** shall mean: (a) an individual, sole proprietorship, corporation, limited liability company, partnership, joint venture, joint stock company, estate, trust, limited liability association, unincorporated association or other entity or organization; (b) any Federal, State, county or municipal government (or any bureau, department, agency or instrumentality thereof); and (c) any fiduciary acting in such capacity on behalf of any of the foregoing.

**“Phase”** as used herein, shall mean any one of the various phases, or distinct, contiguous portions of time, of the Trade Contractor Work.

**“Project”** shall mean the work provided for in this Trade Contract Agreement and any related work, including design work and work performed under other related Trade Contract Agreements.

**“Project Labor Agreement”** shall mean an agreement by which labor organizations agree to terms and conditions of employment, to cooperate in resolving labor disputes, and to maintain labor peace on the Project.

**“Project Manual”** shall mean a written volume assembled for the Trade Contractor Work by the Trade Contractor that includes specific instructions to the Project Team setting forth the requirements, policies and procedures for performance and execution of the Trade Contractor’s Design Services and Trade Contractor Work.

**“Project Participant”** shall mean a member of the Project Team.

**“Project Safety Program”** shall be developed by Trade Contractor pursuant to this Agreement and Terms of Design and Construction.

**“Project Site”** shall mean the site where the Project is to be constructed.

**“Project Team”** shall mean any Person involved in the Project and under a contract with the Authority or Team, including the Construction Manager and its Subcontractors, Sub-Subcontractors, Suppliers, Vendors, the Architect and its Subconsultants of any tier, Trade Contractors of all tiers contracted directly by the Authority and Consultants contracted directly by the Authority or Team. The Authority must be presented, and asked to provide written approval of, all agreements or contracts, consistent with the terms and conditions of the Trade Contract Documents, with any member of the Project Team before any services or Trade Contractor Work is to be provided or performed on the Project by any such member.

**“Punchlist”** shall mean a list, compiled by the Trade Contractor and reviewed by the Architect or Authority at Substantial Completion, and approved by the Authority, which identifies items of Trade Contractor Work that remain to be completed or corrected prior to acceptance of Final Completion.

**“Record Drawings”** shall mean a reproducible set of Construction Documents into which the Architect has incorporated: (a) clarifications, sketches and other Modifications made by the Architect during the Construction Phase; and (b) significant changes in the Work made during construction as shown on the Trade Contractor’s As-Built Drawings.

**“Regulated Substance”** shall mean any substance, material or waste, regardless of its form or nature, defined under Environmental Laws as a “hazardous substance,” “hazardous waste,” “toxic substance,” “extremely hazardous substance,” “toxic chemical,” “toxic waste,” “solid waste,” “industrial waste,” “residual waste,” “municipal waste,” “special handling waste,” “mixed waste,” “infectious waste,” “chemotherapeutic waste,” “medical waste,” “regulated substance,” “pollutant” or “contaminant” or any other substance, material or waste, regardless of its form or nature, which otherwise is regulated by Environmental Laws.

**“Required Insurance”** shall mean the insurance required of the Trade Contractor pursuant to the Trade Contract Agreement and **Appendix B**.

**“Response Action”** shall mean the investigation, cleanup, removal, remediation, containment, control, abatement, monitoring of or any other response action to the presence of Regulated Substances or Contamination in, on, at, under or emanating from the Stadium Site, including the correction or abatement of any violation required pursuant to Environmental Laws or by a Governmental Authority.

**“Samples”** shall mean physical examples that illustrate materials, items of workmanship, and which establish standards by which the Trade Contractor Work will be judged.

**“Scheduled Event”** shall mean any amateur or professional sporting event (other than a NFL game), exhibition, tournament, musical or theatrical performance and other form of live or broadcasted entertainment, convention meeting, market, or show for which (a) the reasonably expected paid attendance is at least 10,000 Persons and for which tickets or concessions are sold to those attending, or (b) expenses incurred with loss of such Scheduled Event would be at least \$100,000.

**“Scheduled Substantial Completion Date”** shall have the meaning set forth in **Exhibit 6** of the Trade Contractor Agreement.

**“Schedule of Values”** shall mean an allocation of the entire Trade Contract Agreement among the various portions of the Trade Contractor Work as reasonably approved by the Authority and to be provided by the Trade Contractor.

**“Schematic Design Documents”** means drawings prepared by the Trade Contractor that illustrate the scale and relationship of the various Trade Contractor Work components and which also contain square footage and volume calculations for the building interior spaces, building exterior spaces, and major architectural and interior finishes.

**“Schematic Design Phase”** shall mean that Phase during which the Schematic Design Documents are being prepared by the Trade Contractor.

**“Shop Drawings”** shall mean drawings, diagrams, illustrations, schedules, performance checks and other data prepared by the Trade Contractor or any Subcontractor to illustrate how a specified portion of the Trade Contractor Work will be constructed.

**“Specifications”** shall mean the written specifications prepared by the Trade Contractor, Architect, Subconsultants and Consultants consisting of the written requirements for materials, equipment, technical requirements and construction systems, standards and workmanship for the Trade Contractor Work, and performance of related services.

**“Stadium”** shall mean a multipurpose stadium suitable for NFL football and a broad range of other civic, community, athletic, educational, cultural, and commercial activities.

**“Stadium Infrastructure”** shall mean plazas, including the Stadium Plaza, parking structures, rights of way, connectors, skyways and tunnels, and other such property, facilities, and improvements, owned by the Authority or determined by the Authority to be reasonably necessary to facilitate the use and development of the Stadium.

**“Stadium Plaza”** shall mean the open air portion of the Stadium Infrastructure adjacent to the Stadium.

**“Stadium Site”** shall mean all or portions of the current site of the Existing Stadium and adjacent areas, bounded generally by Park and Eleventh Avenues and Third and Sixth Streets in the City of Minneapolis, together with any vacated streets or other lands acquired for the development, construction and use of the Project.

**“Standard of Care”** in regard to the professional Design Services provided by the Trade Contractor shall mean that standard of professional care, skill, diligence and quality that prevail among national design firms engaged in the planning, design, and construction administration of large scale and complex systems of similar scope, function, size, quality, complexity and detail, including the design of similar systems for NFL stadiums in comparable urban areas throughout the United States, and further including performance in accordance with Applicable Laws and the NFL Rules and Regulations.

**“Standard of Care”** in regard to the construction, installation, integration, activation of, and adjustments to, the Trade Contractor Work of the Trade Contractor shall mean that that standard of professional care, skill, diligence and quality that prevail among national firms engaged in the planning, estimating, scheduling, construction, and construction administration of large scale and complex systems of similar scope, function, size, quality, complexity and detail, including the design of similar systems for NFL stadiums in comparable urban areas throughout the United States, and further including performance in accordance with Applicable Laws and the NFL Rules and Regulations.

**“Subconsultant”** shall mean a Person engaged or to be engaged by the Trade Contractor or Architect to perform a portion of the Design Services. The term “Subconsultant” also includes any lower tier Sub-Subconsultant engaged by a Subconsultant.

**“Subcontract”** shall mean a contract between the Trade Contractor and a Subcontractor for the performance of a portion of the Trade Contractor Work.

**“Subcontract Amount”** shall mean the total amount stipulated in a Subcontract to be paid to the Subcontractor for the Subcontractor’s performance of the Subcontract.

**“Subcontractor”** shall mean a Person engaged by the Trade Contractor to perform a portion of the Trade Contractor Work. The term “Subcontractor” also includes any lower tier Sub-Subcontractor engaged by a Subcontractor.

**“Subcontractor Application for Payment”** shall mean an application for payment submitted to the Trade Contractor by a Subcontractor.

**“Submittal”** shall mean a Shop Drawing, Sample, catalog cut or similar item for specific portions of the Work as required by the Construction Documents.

**“Substantial Completion”** shall have the meaning set forth in **Exhibit 6**.

**“Substantial Completion Certificate”** shall mean the certificate issued and approved by the Authority indicating the date upon which the Trade Contractor Work (or a designated portion thereof) is Substantially Complete.

**“Substantial Completion Date” or “Date of Substantial Completion”** shall mean the date identified in the Substantial Completion Certificate when the Trade Contractor Work (or a designated portion thereof) is Substantially Complete.

**“Substitution”** shall mean a replacement for or alternative to an item of material or item identified in the Construction Documents which is proposed by the Trade Contractor and approved in writing by Authority.

**“Sub-Subcontractor”** shall mean a Person engaged by a Subcontractor to perform a portion of the Trade Contractor Work. The term “Sub-Subcontractor” also includes any lower tier Persons engaged by Sub-Subcontractor to perform a portion of the Trade Contractor Work.

**“Supplier”** shall mean a Person who has an agreement with the Trade Contractor, or any member of the Project Team or any of their Subconsultants, Subcontractors or Sub-subcontractors, of any tier, to supply by sale or lease, directly or indirectly, any materials or equipment for the Trade Contractor Work.

**“Suspension”** shall mean a delay, re-sequencing, stoppage and/or interruption of the Trade Contractor Work (in whole or in part), in response to a written directive from the Authority.

**“Targeted Businesses”** shall have the meaning set forth in **Paragraph 10** of the Trade Contract Agreement.

**“Team”** shall mean the Minnesota Vikings Football, LLC, or any Person who purchases or otherwise takes ownership or control of or reconstitutes the NFL team known as the Minnesota Vikings, and Minnesota Vikings Football Stadium, LLC.



**“Termination for Convenience”** shall mean the termination of the Trade Contract Agreement or the Trade Contractor Work by the Authority without cause and for the convenience of the Authority as decided in its sole discretion.

**“Termination for Default”** shall mean the termination of a Party under the Trade Contract Agreement by the Authority for cause.

**“Testing”** shall mean, performing those tests and inspections of the Trade Contractor Work to determine conformance with the Trade Contract Documents.

**“Third-Party Suit”** shall mean a summons and complaint served by a third-party who is not a member of the Project Team against a member of the Project Team, the Authority, or Team in a court of law.

**“Trade Contract”** shall mean a contract between the Authority and a Trade Contractor for the performance of a portion of the Project.

**“Trade Contract Agreement”** shall mean the written agreement between the Authority and the Trade Contractor.

**“Trade Contract Amount”** shall mean the amount to be paid to the Trade Contractor for the proper performance of the Trade Contract Agreement as set forth more fully in **Exhibit 2**.

**“Trade Contract Documents”** shall mean all the design and contract documents prepared by Trade Contractor that are necessary to deliver and complete the Trade Contractor Work and provide fully functioning facilities that satisfy the Trade Contractor’s obligations under the Trade Contract Agreement.

**“Trade Contractor”** shall mean a Person other than the Construction Manager or its Subcontractors that has a direct contract with the Authority to perform a portion of the Project.

**“Trade Contractor Work”** shall mean the complete and total construction or performance described in and required by the Trade Contract Documents, including preconstruction and design services and construction services, whether completed or partially completed, and includes all labor, materials, equipment and services required to be provided by the Trade Contractor to fulfill Trade Contractor’s obligations under the Trade Contract Agreement. The Trade Contractor’s Work may constitute the whole or part of the Project. The Trade Contractor’s Work includes all of the labor, materials, equipment and services to be provided by the Subcontractors, Sub-Subcontractors of any tier, material and equipment suppliers employed directly by the Trade Contractor.

**“Trademark”** shall mean a trademark used by the Authority that is protected under United States or International Trademark Law. Without limiting the foregoing, the term Trademark shall also have the meaning set forth in **Paragraph 1.3** of the Design Services Agreement.

**“Trade Secret”** shall mean any and all information that comes into the possession, custody or control by, through, from, or on behalf of the Authority or Team without regard to form, including, without limitation, any technical or non-technical data, formula, pattern, compilation, program, device, method, technique, drawing, process, financial data, financial plan, product plan, list of actual or potential customers or suppliers, that is not commonly known by or available to the public and which information: (a) derives economic value, actual or potential, from not being generally known to, and not being readily ascertainable by proper means by, other Persons who can obtain economic value from its disclosure or use; and (b) is the subject of efforts that are reasonable under the circumstances to maintain its secrecy.

**“Vendor”** shall mean a party supplying FF&E, equipment, material, or other product or service to the Project under a direct contract with the Authority.

**“Vendor Contract”** shall mean a contract between the Authority and a Vendor for the performance of a portion of the Project.

**INSURANCE PROVISIONS OF THE TERMS OF DESIGN AND CONSTRUCTION**

**APPENDIX B**

**TRADE CONTRACTOR’S INSURANCE REQUIREMENTS**

1. For its design and construction work for the Trade Contractor Work, the Trade Contractor shall, unless otherwise approved in writing by the Authority, obtain and maintain throughout the duration of the Trade Contract Agreement for matters that arise out of or relate to the Trade Contractor Work (or as otherwise specified) insurance of the minimum types and in the minimum amounts described below (“**Required Insurance**”).

**1.1 Commercial General Liability Insurance.**

**1.1.1 Combined single limit of not less than:**

\$1,000,000	Each Occurrence
\$2,000,000	General Aggregate
\$1,000,000	Products/Completed Operations Aggregate
\$1,000,000	Personal and Advertising Injury
\$100,000	Fire Legal Liability
\$10,000	Medical Payments

**1.1.2 Coverage Required:**

- Per project general aggregate,
- Premises-operations,
- Explosion, collapse, underground,
- Products/completed operations,
- Independent contractor,
- Independent Trade Contractor’s Liability,
- Blanket contractual liability, subject to industry standard terms and conditions,
- Personal injury liability,
- Employment Practice Liability (which can be provided through a separate policy)
- Electronic data liability property damage,
- General liability primary (non-contributory),
- Additional insured by endorsement (CG 20 10 10/01 and CG 20 37 10 01 or their equivalent) in a form subject to approval by the Authority including waiver of subrogation in favor of the Authority and the Indemnitees but only as arising out of vicarious liability or warranty liability imposed by law because of the acts, errors, or omissions of the Trade Contractor including additional insured coverage for both ongoing and completed operations,

- Supplementary Payments coverage for the benefit of Indemnitees of the Trade Contractor for property damage, bodily injury, and personal and advertising injury,
- Trade Contractor shall secure such endorsements or estoppel certificates from insurer as may be necessary to confirm that the Trade Contract Agreement is an insured contract for purposes of the policy,
- Designated Construction Project(s) General Aggregate Limit endorsement (CG 25 03 03 97 or its equivalent),
- Operations within 50 feet of railroad,
- Defense in addition to limits of liability,
- Broad form Property Damage coverage,
- Definition of Bodily Injury to include Mental Injury and Mental Anguish,
- Mobile Equipment coverage,
- Liability assumed under an insured contract including the tort liability of another assumed in a business contract,
- Libel, slander, false arrest and invasion of privacy,
- Designated Location(s), and

Coverage shall be written on ISO form CG 00 01 12 04 or an equivalent form. Insurance is to be on an occurrence form insuring bodily injury and property damage against the hazards of: construction operations, subcontractor and independent contractor, and shall include an aggregate limit per job site endorsement.

## **1.2 Business Auto Liability Insurance.**

### **1.2.1 Combined Single Limit of:**

\$1,000,000 each Occurrence Bodily Injury and Property Damage

### **1.2.2 Coverage Required:** Primary for all owned automobiles; including liability for all owned, leased, rented, hired/non-owned automobiles; medical payments, uninsured and underinsured motorists coverage. Coverage shall be written on ISO form CA 00 01, CA 00 05, CA 00 12, CA 00 20, or an equivalent form.

The Authority shall be included as additional insured by endorsement in a form subject to approval by the Authority. An MCS-90 endorsement (or its equivalent) shall be attached when operations require this coverage.

## **1.3 Workers' Compensation Insurance.**

### **1.3.1 Workers' Compensation Limits:** Statutory

**1.3.2 Employers' Liability Limits:**

Bodily Injury by Accident	\$1,000,000	Each Accident
Bodily Injury by Disease	\$1,000,000	Policy Limit
Bodily Injury by Disease	\$1,000,000	Each Employee

**1.3.3** Workers Compensation Insurance shall include coverage for Borrowed Servant and Alternate Employer, Voluntary Compensation, unintentional errors or omissions, FELA (in case RR worker/employee injured due to operations of contractor or their agents), The Alternative Employer endorsement shall be attached showing the Authority in the schedule as the Alternate Employer.

**1.3.4** Waiver of Subrogation Endorsement in favor of the Authority.

**1.4 Excess Liability Insurance with Limits of Not Less Than:**

\$10,000,000	Each Occurrence
\$10,000,000	Aggregate
\$10,000,000	Products/Completed Operations Aggregate

Coverage is materially following form of underlying general liability, automobile liability and employers' liability, coverage including, primary, additional insured/non-contributory, and waiver of subrogation. Coverage shall have "drop down" feature and "pay on behalf of" wording. Excess policy shall be primary and any applicable policy by the Authority, Additional Insureds, Indemnitees, or Subcontractors, shall be secondary and non-contributory.

**1.5 Contractor's Professional Liability.**

\$1,000,000	Limit of Insurance
\$1,000,000	Annual Aggregate

Coverage shall be maintained uninterrupted for a minimum of twelve years after Substantial Completion. Coverage shall apply to negligent acts, errors or omissions arising from the Trade Contractor's professional services defined to include architecture, engineering, land surveying, landscape architecture, and construction management (or other services if appropriate). The retro date will be prior to the commencement of Trade Contractor Work. This coverage must be primary and non-contributory to any coverage maintained by the Authority or an Indemnitee.

**1.6 [RESERVED]**

**1.7 Property Insurance/Builder's Risk**

Trade Contractor shall insure its own property and equipment (owned, rented or borrowed) including but not limited to tools, materials, supplies, equipment, forms, scaffolding towers, staging, bunkhouses, and other temporary structures including their contents. Trade Contractor shall require its Subcontractors to similarly insure their property and equipment. Trade Contractor shall also insure its work on the project and that of its Subcontractors and any materials and equipment that will be incorporated into its work or that of its Subcontractors through Builder's Risk insurance which coverage shall be on an "all risk" basis (with only industry standard exclusions) and shall be kept in force throughout the duration of the Trade Contract Agreement for matters that arise out of or relate to the Trade Contractor Work. The Authority shall be named as an additional insured on the policy as shall Trade Contractor's Subcontractors. The limit of the coverage shall be no less than the Trade Contract amount set forth at Exhibit 2.

2. The Authority does not represent or warrant that coverage and limits of the Required Insurance will be adequate to protect the Trade Contractor, and such coverage and limits shall not be deemed as a limitation on the Trade Contractor's liability under the indemnities provided to the Authority and Indemnitees in the Trade Contract Agreement or any other provision of the Trade Contract Documents.
3. The Trade Contractor represents and warrants that the coverage and limits of the Required Insurance are the coverage and limits currently maintained by the Trade Contractor.
4. Prior to commencing the Trade Contractor Work, the Trade Contractor shall furnish the Authority with a certificate(s) of insurance, executed by a duly authorized representative of each insurer, showing that the Trade Contractor maintains all Required Insurance.
  - 4.1 All certificates shall contain a provision that coverages afforded under the policies will not be cancelled, non-renewed, materially changed, or allowed to expire until at least thirty (30) Days' prior written notice has been given to the Authority. The Trade Contractor shall immediately furnish the Authority copies of all endorsements that are subsequently issued amending coverage or limits.
  - 4.2 The words "endeavor to" and "but failure to mail such notice shall impose no obligation or liability of any kind upon the company, its agents or representatives" shall be deleted from the cancellation or material change of any insurance referred to therein.
  - 4.3 Failure of the Authority to demand such certificate or other evidence of full compliance with the Required Insurance or failure of the Authority to identify a

deficiency from evidence that is provided shall not be construed as a waiver of the Trade Contractor's obligation to maintain such insurance.

5. The Authority shall have the right, but not the obligation, to prohibit the Trade Contractor from entering the Project Site until such certificates or other evidence that the Required Insurance has been duly placed in compliance with this **Appendix B**. The Trade Contractor shall be responsible for any delays arising out of the Trade Contractor's failure to comply with this **Appendix B**.
6. If the Trade Contractor fails to maintain any or all of the Required Insurance, then, in addition to any other rights or remedies available to the Authority under the Agreement, the Authority shall have the right, but shall not be obligated, to (a) terminate the Trade Contract Agreement, or (b) purchase such insurance for the Trade Contractor in which event the Trade Contractor shall reimburse the Authority or provide for the cost thereof, plus ten percent (10%) as an administrative charge.
7. With respect to the Required Insurance, which the Trade Contractor is obligated to maintain after Substantial Completion, an additional certificate(s) evidencing such coverage shall be promptly provided to the Authority when requested.
8. Trade Contractor shall provide certificates of insurance evidencing the insurance coverage and policy limits required above prior to commencement of the Trade Contractor Work and thereafter shall provide insurance certificates or certified copies of insurance policies as may be specified by the Authority within ten (10) Days of the Authority's written request for said certificates or copies.
9. Trade Contractor will require Subcontractors to provide insurance in accordance with the terms and conditions of its standard Subcontract Agreement. Trade Contractor shall include the above additional insured and waiver of subrogation requirements in all of its Subcontracts, unless otherwise agreed to in writing by the Authority. The Trade Contractor shall be responsible for collecting certificates of insurance and monitoring insurance coverage of its Subcontractors and all lower tier Sub-Subcontractors to verify that the required coverage is maintained as required. All Subcontractors providing professional services shall be required to provide professional liability insurance. In addition, all Subcontractors shall include the same indemnification of the Authority and Indemnitees as provided in the Trade Contract Agreement.
10. Trade Contractor shall secure all Required Insurance from domestic insurer(s) authorized to do business in the State of Minnesota and reasonably satisfactory to the Authority with: (a) a claims paying ability of not less than "AA" (or the equivalent) by Standard & Poors and one other Rating Agency satisfactory to the Authority; and (b) "A:X" or better financial strength rating by AM Best. Trade Contractor shall promptly notify the Authority of any material changes in coverage for all insurance required herein. All coverages except Professional Liability insurance shall be occurrence based. Insurance shall contain such provisions as the Authority deems reasonably necessary or desirable to protect its interest, including endorsement stating that neither the Trade Contractor, the Authority,

nor any other party shall be deemed a co-insurer. The Trade Contractor shall pay the premiums for all insurance when due and payable.



---

**EXHIBIT 1**  
**DESCRIPTION OF TRADE CONTRACTOR WORK**

---

The following description is included in the scope of the Trade Contractor Work as **Exhibit 1**:

The design, work, services, labor, materials, and equipment to be provided by the Trade Contractor and its Subcontractors, Suppliers, Consultants and Subconsultants of any tier and associated with the Trade Contractor Work for the Project are described below, and it is the intention of the Trade Contract Agreement that the Trade Contractor shall provide all design, work, services, labor, materials, and equipment to complete the Trade Contractor Work in accordance with the Trade Contract Agreement, including the Trade Contract Documents and all Applicable Laws.

The Trade Contractor Work shall include the following, without limitation:

**1. Design Services.**

(a) Trade Contractor shall provide Design Services for the Trade Contractor Work in a manner consistent with the Standard of Care whether performed by the Trade Contractor, its Consultants or any Person engaged directly or indirectly by the Trade Contractor. All staff used by the Contractor in the performance of the Design Services under this Trade Contract Agreement shall be qualified by training and experience to perform their assigned tasks. Trade Contractor's Design Services shall include usual and customary structural, mechanical and electrical engineering services necessary to complete the Trade Contractor Work. Trade Contractor represents that it is: (i) knowledgeable of the Applicable Laws in connection with its scope of Design Services under this Trade Contract Agreement, including all health, safety, fire, environmental, building and zoning codes, rules and regulations, and agrees to comply with each of the foregoing; (ii) experienced and fully qualified to perform the Design Services under this Trade Contract Agreement; and (iii) properly licensed, certified, registered and organized to perform such Design Services under Applicable Laws or any similar requirements.

(b) As part of the consideration contained in the Trade Contract Amount, Trade Contractor and its Consultants and sub-Consultants unconditionally and irrevocably transfer and assign to the Authority all rights, title and interest of any kind or nature in and to their respective Design Documents. Trade Contractor and its Consultants and sub-Consultants acknowledge and agree that for copyright purposes any Design Documents produced or prepared by Trade Contractor and/or its Consultants or sub-Consultants in connection with this Trade Contract Agreement shall be considered works made for hire under Applicable Law, specially ordered or commissioned by the Authority. If, and to the extent that, such Design Documents are deemed not to be works made for hire by a court of competent jurisdiction or an arbitrator, then this Trade Contract Agreement shall constitute an irrevocable assignment and transfer to

the Authority of the copyright in all such Design Documents, including the exclusive rights to reproduce, perform and distribute such Design Documents. The Authority shall have the sole right to bring enforcement actions for infringement of any and all such rights, and the Trade Contractor and its Consultants and sub-Consultants hereby assign any causes of action that may have accrued or will accrue with respect to in such documents, materials, trademarks, service marks and copyrights.

## **2. Construction Services.**

Trade Contractor will provide all labor, materials and equipment necessary to survey, design, engineer, fabricate, ship and install the Trade Contractor Work.

### **Design**

Trade Contractor will provide design services to establish aesthetic and structural specifications for the Trade Contractor Work, including required supporting structure and attachment elements. Scope includes all revision and refinement labor time to reach final acceptance and approval by the Authority and Team.

### **Project Management**

Trade Contractor will provide dedicated project management staff time from project execution to final punch list and acceptance of completed Trade Contractor Work by the Authority and Team. Trade Contractor will coordinate all Trade Contractor Work with the Authority, Team, Construction Manager, Architect, other contractors, and all members of the Project Team.

### **Site Survey and Scope Review**

Before generating any drawings or documents, Trade Contractor will conduct a full site survey to confirm that all existing conditions are adequate to meet the design intent. Trade Contractor will request and coordinate delivery for its review of drawings or other documentation showing or describing the existing conditions, coordinating trades and proposed work proposed to be provided by others. Any specific structural or other modifications to the Stadium structure will be immediately communicated to the Authority and Team for evaluation.

### **Shop Drawings**

Trade Contractor will generate for submittal and approval complete Shop Drawings defining each of the elements of Trade Contractor Work to be fabricated and installed by Trade Contractor. These Drawings will show the location/placement of each component of the Trade Contractor Work and will detail construction methods, "hardening" of components or methods, materials, colors, installation methods, and any applicable coordination information for each element type for its own Trade Contractor Work and with the Work of other adjacent contractors. Drawings will be based on existing Design Documents, site survey,

and any further information received during the design phases, and as coordinated with the Architect, Authority, and Team. Shop Drawings are required for each component type and include: specially-prepared technical data for this Project, drawings, diagrams, schedules, templates, patterns, instructions, measurements, and similar information not in standard print form.

### **Material/Control Samples**

Trade Contractor will submit samples of each material type, and finish and paint color(s), including both fabricated and un-fabricated physical examples of materials, products and units of work. Samples may be both complete units and smaller portions of units of work, either for limited visual inspection or, where indicated, for more detailed testing and analysis.

### **Engineering Calculations**

Engineering calculations will be provided with the Shop Drawings. Engineering calculations will contain information showing that each component and attachment/installation methods will meet the load requirements. Trade Contractor will cause all engineered drawings and documents to be prepared and stamped by a Professional Engineer licensed in Minnesota.

### **Mock-ups**

After approval of Shop Drawings and material samples, and only if requested by the Authority and Team, Trade Contractor will construct mock-ups to verify constructability of fabricated components and illustrate final product for review by the Authority and Team. Mock-ups will be constructed in the same manner as the final product using the same materials and processes to ensure that the requirements of the project are being met before Trade Contractor commences production.

### **Shop Testing**

Fabricated components will be shop tested prior to shipment or delivery to the Project Site.

### **Material Procurement**

The Trade Contractor will order and procure materials as required to maintain the Project schedule. If alternate materials are requested by the Authority or Team, Trade Contractor will advise of any alleged time impacts.

### **Shipping**

All fabricated components will be crated for shipment to the Project Site or off-site storage in a coordinated sequence to facilitate the installation process. All components will be crated in a manner to prevent any damage during transit or storage.

## **Installation**

Trade Contractor will provide onsite installation supervision as required for the unpacking and installation phase of the Trade Contractor Work. Trade Contractor will protect its Work from public access during construction. Trade Contractor will either provide its own safe storage of materials and equipment, toilet facilities, dumpsters/waste removal, and portable cranes, or arrange for the use of the same from the Construction Manager.

## **Project Closeout**

Trade Contractor will prepare and submit all closeout components, including, but not limited to, assembly manuals, maintenance manuals, and closeout package, in printed and PDF format. Documents shall include approved shop drawings annotated with revisions that reflect any changes in the field. Product data are to be provided to the Authority and Team in the form of an Operations and Maintenance Manual. Product data shall include standard printed information on materials, products and systems, including material safety data sheets (MSDS), and not specially prepared for the Trade Contractor Work.

## **Scope Components and Description:**

- **Vendor shall provide the following in relation to proposal:**
  - **All pricing shall include freight, tax, sourcing, install, commissioning, permitting when required, uncrating of materials and discarding of packing materials in agreed on disposal location,.**
  - **Vendor shall provide all labor and tools associated with or required to complete tasks as noted above and below.**
  - **Should additional parties be required for any installation vendor shall source and provide resources to accomplish install of equipment.**
  - **Full list of equipment found below:**

**Optional Alternative options suggested in this proposal shall be accompanied by product specification sheets and associated costing for each item listed.**

---

**EXHIBIT 2**  
**TRADE CONTRACT AMOUNT**

---

Trade Contractor acknowledges that this Trade Contract Agreement is a fixed-sum contract in the amount of [\_\_\_\_\_ and \_\_\_\_/100 Dollars (\$\_\_\_\_\_)] (the “Trade Contract Amount”) for all Trade Contractor Work. The Trade Contract Amount shall be complete and total compensation for all of Trade Contractor’s fees and expenses including, but not limited to: (i) all wages, benefits and related taxes either direct or subcontracted, (ii) all shop expenses, design fees, general overhead, taxes, telecommunications and any other costs of business or miscellaneous expenses; (iii) all travel expenses and related costs, including but not limited to, airfare, ground transport, accommodations, meals, and incidental travel expenses for Trade Contractor, its staff and associated workers, (iv) all materials whether directly purchased or purchased by subcontractors, (v) insurance coverage at limits required in this Trade Contract, and (vi) all crating, packing, shipping, transport and drayage costs, of whatsoever kind, for the Trade Contractor Work and for any and all tools and materials which Trade Contractor may need to perform its Trade Contract Work.

**[See Next Page]**



## EXHIBIT 2

Describe the equipment and materials, if any, that will be provided to the MSFA and detail all quantities and unit prices for the equipment and materials listed below. In addition, include installation labor costs, freight, and Minnesota sales tax.

Quantity	Materials Description	Price
2	Double Shelf Heat Slide-Hatco (GRDS-36D): Add stainless side panels in place of glass. Add flip up plexi door in front. Nema 5-20p plug.	
3	Vent Less Fryer-Wells (WVAE-55F)	
1	Dough Sheeter-Somerset (CDR-500) Item shall have the following modifications: adjustable 4" legs, synthetic rollers, and be single phase 115v/60hz	
4	Portable Fry Holding Station-Hatco (GRFH-26) Table top fry dump station with fry scoop holder and additional (2) sectional dividers for each unit. Nema 5-15p plug	
4	Portable Bar-TABCO (AMD-5B) 61" heavy duty portable bar with stainless steel doors and interior. Top and front should be upgraded to stainless steel. Item to include ice bin with drain and shut off valve, perimeter bumpers, 6" heavy duty caster with swivel and at least 2 breaks.	
	<b>Subtotal Materials</b>	
	<b>Installation Labor</b>	
	<b>Freight</b>	
	<b>Minnesota Sales Tax (6.875%)</b>	
	<b>Total</b>	

---

**EXHIBIT 3**  
**TARGETED BUSINESS COMMITMENT AND INFORMATION FORM**

---

[See Next Page]



**TRADE CONTRACT AGREEMENT EQUITY PLAN  
TARGETED BUSINESS COMMITMENT AND INFORMATION FORM**

Proposer Company Name: \_\_\_\_\_

Check ONE of the following:

No Targeted Business participation is committed on this project

The following Targeted Business (MBE & WBE) participation is committed on this project:

Firm Name (Legal business name used for Targeted Business certification)	WBE MBE (Check one)		How will firm participate? (subcontractor, consortium, joint venture)	Description of work	Estimated dollar value of participation	Estimated percentage of total bid

Total WBE % \_\_\_\_\_

Total MBE % \_\_\_\_\_

**TARGETED BUSINESSES WHO WERE CONSIDERED BUT WERE NOT SELECTED:**

Firm Name	Address	Telephone Number

**Certification**

On behalf of the proposer identified below, I certify that the information provided in this form is true and correct.

Proposer Name: \_\_\_\_\_

Signature: \_\_\_\_\_

Date: \_\_\_\_\_

Name: \_\_\_\_\_

Title: \_\_\_\_\_

---

**EXHIBIT 4**  
**TARGETED BUSINESS INFORMATION FORM**

---

[See Next Page]

---

**EXHIBIT 5**  
**TCA EQUITY PLAN PROGRESS REPORT**

---

[See Next Page]



-----

**EXHIBIT 6**  
**CONSTRUCTION SCHEDULE**

-----

The Trade Contractor shall perform its Trade Contractor Work expeditiously and consistent with its contractual obligations to further the orderly progress of the Trade Contractor Work. The Trade Contractor’s Work shall be commenced on the Effective Date, and, subject to authorized adjustments and excusable delays as allowed by the Trade Contract Agreement, Trade Contractor shall achieve Project Milestone Dates and Substantial Completion of its Trade Contractor Work in accordance with this **Exhibit 6**.

Final Completion of the Trade Contractor Work shall be deemed to have occurred only after completion of all the Trade Contractor Work and acceptance of it by the Authority.

The Date of Substantial Completion is described in more detail below:

**Substantial Completion**

Milestone Dates of the Trade Contractor Work that must be complete in accordance herewith are outlined on the Outline of Construction Schedule below. For purposes of this **Exhibit 6**, “**Scheduled Substantial Completion Date**” shall mean [REDACTED], 2018 and “**Guaranteed Completion Date**” shall mean the date set forth across from the corresponding unit or phase of Trade Contractor Work on the Outline of Construction Schedule set forth below.

The following Outline of Construction Schedule highlights critical components of the Project and mandatory Milestone Dates that must be completed, without exception, by the Trade Contractor in order to meet the requirements of the Construction Schedule and Substantial Completion.

The Parties acknowledge and agree, in accordance with **Paragraph 2.11** to the Trade Contract Agreement, that the Trade Contractor will undertake Extraordinary Measures if the Authority determines that the performance of the Trade Contractor Work has not progressed or reached the level of completion required by the Milestone Dates for Trade Contractor’s Work in the Outline of Construction Schedule or if Trade Contractor’s Work is interfering with or delaying the Construction Manager’s work and timely Completion of the Construction Manager’s work pursuant to the Master Project Schedule.

**OUTLINE OF CONSTRUCTION SCHEDULE**

Description of Trade Contractor Work	Start Date	Guaranteed Completion Date	Comments
Design and Install of			
<b>** Work to be coordinated with other Subcontractors in each area.</b>			

---

**EXHIBIT 7**  
**BONDS**

---

The Payment and Performance Bond forms that the Trade Contractor is required to provide related to its Trade Contractor Work are attached as **Exhibit 7**.

[See Next Page]

**TRADE CONTRACTOR LABOR AND MATERIAL PAYMENT BOND**

**THIS BOND, ISSUED SIMULTANEOUSLY WITH A PERFORMANCE BOND, RUNS IN FAVOR OF  
OBLIGEE AND CLAIMANTS**

**Bond Number:** \_\_\_\_\_

**KNOW ALL PERSONS BY THESE PRESENTS:**

**That** \_\_\_\_\_ as Principal, hereinafter  
(Here insert full name and address of Trade Contractor)  
**and,** \_\_\_\_\_ as Surety, hereinafter  
(Here insert full name and serving address of Surety)

called Surety, are held and firm bound unto **Minnesota Sports Facilities Authority, 1005 4<sup>th</sup> Street South, Minneapolis, MN 55415 (the "Authority")**, hereinafter called Obligee, in the amount of \$ \_\_\_\_\_ (the "Bond Sum") for the payment whereof Trade Contractor and Surety, jointly and severally, bind themselves, their heirs, executors, administrators, successors, and assigns firmly by these presents.

**WHEREAS**, Trade Contractor has, by written agreement dated as of \_\_\_\_\_, entered into a Trade Contract with Obligee, Hereinafter called contract, for

\_\_\_\_\_  
(Insert name and location of the project & contact number or general description of the work)

Which contract is by reference made a part hereof.

**NOW THEREFORE**, Trade Contractor and Surety, jointly and severally, hereby bind themselves, their heirs, executors, administrators, successors and assigns to Obligee to pay for costs for work, skill, tools, machinery, materials, insurance premiums, equipment or supplies or taxes incurred under Minn. Stat. §290.92, Chapter 268 or Chapter 297A (the underline portion hereof referred to as "labor, materials, or equipment") provided to Obligee by Trade Contractor for use in the performance of the Contractor:

**THE CONDITION OF THIS BOND** is such that, if Trade Contractor shall satisfactorily perform each part of the Contract and any warranties and guaranties required under the Contract, then this Bond shall be null and void; otherwise it shall remain in full force and effect, inclusive of all the prior recitals and the following terms which are herein incorporated.

Whenever Trade Contractor shall be, and is declared by Obligees to be in default under the Contract, Obligees having performed Obligees obligations thereunder, Surety may promptly remedy the default, or shall promptly

1) Complete the Contract in accordance with its terms and conditions; or

2) Obtain a bid or bids for completing the Contract in accordance with its terms and conditions, and upon determination by Surety of the lowest responsible bidder, or, if Obligees elects, upon determination by Obligees and Surety jointly of the lowest responsible bidder, arrange for a contract between such bidder and Obligees, and make available as Work progresses (even though there should be a default or a succession of defaults under the contract or contracts of completion arranged under this paragraph) sufficient funds to pay the cost of completion less the balance of the Contract's Guaranteed Maximum Price; but not exceeding, including other costs and damages for which Surety may be liable hereunder, the Bond Sum. The term "cost of completion" includes, without limitation, responsibilities of Trade Contractor for correction of defective work and completion of the Contract, Obligees legal and design professional costs resulting from Trade Contractor's default, and all damages recoverable under the Contract, including delay damages.

The term "balance of the Contract's Guaranteed Maximum Price, shall mean the total amount payable by Obligees to Trade Contractor under the Contract and any amendments thereto, less the amount paid by Obligees to Trade Contractor.

Any suit or arbitration under this Bond must be instituted before the expiration of the time in which suits or arbitrations may be brought under the Contract by Obligees in the jurisdiction where the Contract is to be performed, such period to be computed from the later of (1) the date of Trade Contractor's default; or (2) the date Surety refuses or fails to perform its obligations under this Bond, or (3) the date of Substantial Completion of the Project as established by the Contract.

Surety shall save Obligees harmless from all costs and charges, up to the amount of the Bond Sum, that may accrue to complete the Work of the Contract following the default of the Trade Contractor. Surety shall not be liable to Obligees in excess of the Bond Sum, as such Bond Sum may be adjusted as provided in the Contract and herein. The amount of this Bond shall be reduced by and to the extent of any payment or payments made in good faith hereunder.

Surety's obligations shall include, up to the Bond Sum, payment for liquidated delay damages owed under the Contract by Trade Contractor to Authority as a result of late completion as provided for in, or governed by, the Contract.

Terms capitalized herein but not defined in this Bond shall have the meaning assigned to them as noted in the Contract.

This Bond shall remain in effect for the longer period of time in which an action may be maintained under the Contract or under Minn. Stat. §574.31, sub 1, as may be amended or succeeded from time to time.

Surety further agrees that in event of any default by the Authority in the performance of the Authority's obligations to the Trade Contractor under the Contract, the Trade Contractor or Surety shall cause written notice of such default, specifying said default in detail, to be given to the Authority. Such notice of default shall be sent by certified or registered U.S. Mail, return receipt requested, first class postage prepaid, to the Authority.

Surety agrees that it is obligated under the bonds to the Authority and to any successor, grantee or assignee of the Authority.

In any claim involving the Obligees, Surety and the Trade Contractor, the Surety shall be bound by and agrees to be a party to the dispute resolution provisions in the Contract, including any arbitration provision therein, and agrees Obligees has the right to join Surety by consolidation or joinder in any other related arbitration with persons bound to arbitrate with the Obligees. The foregoing agreement to arbitrate and consolidate and joinder shall be specifically enforceable under Applicable Laws in any court having jurisdiction thereof.



Signed and acknowledged and sealed this \_\_\_\_\_ day of \_\_\_\_\_, 20\_\_\_\_.

\_\_\_\_\_  
(Trade Contractor as Principal)

\_\_\_\_\_  
(Surety) (Seal)

By: \_\_\_\_\_  
(Signature)

By: \_\_\_\_\_  
(Signature)

\_\_\_\_\_  
(Print Name)

\_\_\_\_\_  
(Print Name)

\_\_\_\_\_  
(Title)

\_\_\_\_\_  
(Title)

(Trade Contractor signature must be notarized)

(Surety signature must be notarized)  
(Bond must be accompanied by a notarized power of attorney  
authorizing the above signature on behalf of Surety)

Name and servicing address of agent of Surety:

\_\_\_\_\_

\_\_\_\_\_

Telephone: \_\_\_\_\_

## CORPORATE ACKNOWLEDGMENT

State of \_\_\_\_\_ )

) ss

County of \_\_\_\_\_ )

On this \_\_\_\_\_ day of \_\_\_\_\_, before me appeared \_\_\_\_\_, to me personally known, who, being by me duly sworn, did say that he/she is the \_\_\_\_\_ of \_\_\_\_\_, a corporation, that the seal affixed to the foregoing instrument is the corporate seal of said corporation, and that said instrument was executed in behalf of said corporation by the authority of its Board of Directors, and that said \_\_\_\_\_ acknowledged said instrument to be the free act and deed of said corporation.

Notary Public: \_\_\_\_\_

County: \_\_\_\_\_

My Commission Expires: \_\_\_\_\_

**SURETY ACKNOWLEDGMENT**

State of Minnesota            )  
  ) ss  
County of Hennepin         )

On this \_\_\_\_\_ day of \_\_\_\_\_, \_\_\_\_\_ before me appeared \_\_\_\_\_,  
to me personally known, who being by me sworn, did say that (s)he is the Attorney-in Fact of  
\_\_\_\_\_, a corporation, that  
the seal affixed to the foregoing instrument is the corporate seal of said corporation and that  
said instrument was executed in behalf of said corporation by authority of its Board of  
Directors; and that said \_\_\_\_\_ acknowledged  
said instrument to be the free act and deed of said corporation.

Notary: \_\_\_\_\_

County: \_\_\_\_\_

My Commission Expires: \_\_\_\_\_

**TRADE CONTRACTOR LABOR AND MATERIAL PAYMENT BOND**

**THIS BOND, ISSUED SIMULTANEOUSLY WITH A PERFORMANCE BOND, RUNS IN FAVOR OF OBLIGEE AND CLAIMANTS**

**Bond Number:** \_\_\_\_\_

**KNOW ALL PERSONS BY THESE PRESENTS:**

**That** \_\_\_\_\_ as Principal, hereinafter  
(Here insert full name and address of Trade Contractor)

**and,** \_\_\_\_\_ as Surety, hereinafter  
(Here insert full name and serving address of Surety)

called Surety, are held and firm bound unto **Minnesota Sports Facilities Authority, 1005 4<sup>th</sup> Street South,**

**Minneapolis, MN 55415 (the "Authority"),** hereinafter called Obligee, in the amount of

\$\_\_\_\_\_ (the "Bond Sum") for the payment whereof Trade Contractor and Surety, jointly and severally, bind themselves, their heirs, executors, administrators, successors, and assigns firmly by these presents.

**WHEREAS,** Trade Contractor has, by written agreement dated as of \_\_\_\_\_, entered into a Trade Contract with Obligee, Hereinafter called contract, for

\_\_\_\_\_  
(Insert name and location of the project & contact number or general description of the work)

Which contract is by reference made a part hereof.

**NOW THEREFORE,** Trade Contractor and Surety, jointly and severally, hereby bind themselves, their heirs, executors, administrators, successors and assigns to Obligee to pay for costs for work, skill, tools, machinery, materials, insurance premiums, equipment or supplies or taxes incurred under Minn. Stat. §290.92, Chapter 268 or Chapter 297A (the underline portion hereof referred to as "labor, materials, or equipment") provided to Obligee by Trade Contractor for use in the performance of the Contractor:

**THE CONDITION OF THIS BOND** is such that, if Trade Contractor shall satisfactorily perform each part of the Contract and any warranties and guaranties required under the Contract, then this Bond shall be null and void; otherwise it shall remain in full force and effect, inclusive of all the prior recitals and the following terms which are herein incorporated.

Whenever Trade Contractor shall be, and is declared by Obligees to be in default under the Contract, Obligees having performed Obligees obligations thereunder, Surety may promptly remedy the default, or shall promptly

1) Complete the Contract in accordance with its terms and conditions; or

2) Obtain a bid or bids for completing the Contract in accordance with its terms and conditions, and upon determination by Surety of the lowest responsible bidder, or, if Obligees elects, upon determination by Obligees and Surety jointly of the lowest responsible bidder, arrange for a contract between such bidder and Obligees, and make available as Work progresses (even though there should be a default or a succession of defaults under the contract or contracts of completion arranged under this paragraph) sufficient funds to pay the cost of completion less the balance of the Contract's Guaranteed Maximum Price; but not exceeding, including other costs and damages for which Surety may be liable hereunder, the Bond Sum. The term "cost of completion" includes, without limitation, responsibilities of Trade Contractor for correction of defective work and completion of the Contract, Obligees legal and design professional costs resulting from Trade Contractor's default, and all damages recoverable under the Contract, including delay damages.

The term "balance of the Contract's Guaranteed Maximum Price, shall mean the total amount payable by Obligees to Trade Contractor under the Contract and any amendments thereto, less the amount paid by Obligees to Trade Contractor.

Any suit or arbitration under this Bond must be instituted before the expiration of the time in which suits or arbitrations may be brought under the Contract by Obligees in the jurisdiction where the Contract is to be performed, such period to be computed from the later of (1) the date of Trade Contractor's default; or (2) the date Surety refuses or fails to perform its obligations under this Bond, or (3) the date of Substantial Completion of the Project as established by the Contract.

Surety shall save Obligees harmless from all costs and charges, up to the amount of the Bond Sum, that may accrue to complete the Work of the Contract following the default of the Trade Contractor. Surety shall not be liable to Obligees in excess of the Bond Sum, as such Bond Sum may be adjusted as provided in the Contract and herein. The amount of this Bond shall be reduced by and to the extent of any payment or payments made in good faith hereunder.

Surety's obligations shall include, up to the Bond Sum, payment for liquidated delay damages owed under the Contract by Trade Contractor to Authority as a result of late completion as provided for in, or governed by, the Contract.

Terms capitalized herein but not defined in this Bond shall have the meaning assigned to them as noted in the Contract.

This Bond shall remain in effect for the longer period of time in which an action may be maintained under the Contract or under Minn. Stat. §574.31, sub 1, as may be amended or succeeded from time to time.

Surety further agrees that in event of any default by the Authority in the performance of the Authority's obligations to the Trade Contractor under the Contract, the Trade Contractor or Surety shall cause written notice of such default, specifying said default in detail, to be given to the Authority. Such notice of default shall be sent by certified or registered U.S. Mail, return receipt requested, first class postage prepaid, to the Authority.

Surety agrees that it is obligated under the bonds to the Authority and to any successor, grantee or assignee of the Authority.

In any claim involving the Obligees, Surety and the Trade Contractor, the Surety shall be bound by and agrees to be a party to the dispute resolution provisions in the Contract, including any arbitration provision therein, and agrees Obligees has the right to join Surety by consolidation or joinder in any other related arbitration with persons bound to arbitrate with the Obligees. The foregoing agreement to arbitrate and consolidate and joinder shall be specifically enforceable under Applicable Laws in any court having jurisdiction thereof.

Signed and acknowledged and sealed this \_\_\_\_\_ day of \_\_\_\_\_, 20\_\_\_\_.

\_\_\_\_\_  
(Trade Contractor as Principal)

\_\_\_\_\_  
(Surety) (Seal)

By: \_\_\_\_\_  
(Signature)

By: \_\_\_\_\_  
(Signature)

\_\_\_\_\_  
(Print Name)

\_\_\_\_\_  
(Print Name)

\_\_\_\_\_  
(Title)

\_\_\_\_\_  
(Title)

(Trade Contractor signature must be notarized)

(Surety signature must be notarized)  
(Bond must be accompanied by a notarized power of attorney authorizing the  
above signature on behalf of Surety)

<p align="center"><u>Name and servicing address of agent of Surety:</u></p> <p>_____</p> <p>_____</p> <p>Telephone: _____</p>
---

## CORPORATE ACKNOWLEDGMENT

State of \_\_\_\_\_ )

) ss

County of \_\_\_\_\_ )

On this \_\_\_\_\_ day of \_\_\_\_\_, before me appeared \_\_\_\_\_,  
to me personally known, who, being by me duly sworn, did say that he/she is  
the \_\_\_\_\_ of \_\_\_\_\_,  
a corporation, that the seal affixed to the foregoing instrument is the corporate seal of said  
corporation, and that said instrument was executed in behalf of said corporation by the  
authority of its Board of Directors, and that said \_\_\_\_\_  
acknowledged said instrument to be the free act and deed of said corporation.

Notary Public: \_\_\_\_\_

County: \_\_\_\_\_

My Commission Expires: \_\_\_\_\_

**SURETY ACKNOWLEDGMENT**

State of Minnesota        )  
                                      ) ss  
County of Hennepin        )

On this \_\_\_\_\_ day of \_\_\_\_\_, \_\_\_\_\_ before me appeared \_\_\_\_\_,  
to me personally known, who being by me sworn, did say that (s)he is the Attorney-in Fact of  
\_\_\_\_\_, a corporation, that  
the seal affixed to the foregoing instrument is the corporate seal of said corporation and that  
said instrument was executed in behalf of said corporation by authority of its Board of  
Directors; and that said \_\_\_\_\_ acknowledged  
said instrument to be the free act and deed of said corporation.

Notary: \_\_\_\_\_

County: \_\_\_\_\_

My Commission Expires: \_\_\_\_\_



---

**EXHIBIT 8**  
**WARRANTY**

---

The following Warranty is included in this Trade Contract Agreement as Exhibit 8.

**WARRANTY**

Pursuant to the Trade Contract Agreement between the Minnesota Sports Facilities Authority ("**Authority**") and \_\_\_\_\_ ("**Trade Contractor**"), Trade Contractor hereby warrants and guarantees that all of the Trade Contractor Work performed under the Trade Contract Agreement will be of new and of good quality, will be free of defects except for those inherent in the quality of the Trade Contractor Work allowed by the Trade Contract Documents, and will conform to the requirements of the Trade Contract Documents ("**Warranty**"). If the Trade Contractor Work does not conform to this Warranty, it shall be considered defective, and Trade Contractor shall remedy at its own expense any such defective Trade Contractor Work (including the costs that the Authority or Architect incur in dealing with or as a result of the defective Trade Contractor Work) so that the Trade Contractor Work conforms to the Trade Contract Documents. The Trade Contractor's Warranty shall extend for a period of one (1) year after final acceptance by Authority. Where guarantees or warranties are required in the Trade Contract Documents for a period of more than one (1) year, such longer terms shall apply. All Suppliers' warranties and guarantees, express or implied, respecting any part of the Trade Contractor Work and any materials used therein are hereby assigned by the Trade Contractor to the Authority. This Warranty shall supplement, and not supersede, warranties and guarantees given by Trade Contractor under the terms of the Trade Contract Documents.

TRADE CONTRACTOR:

WITNESS: \_\_\_\_\_

Title: \_\_\_\_\_

Date: \_\_\_\_\_

STATE OF \_\_\_\_\_

COUNTY OF \_\_\_\_\_

BEFORE ME, the undersigned authority, on this day, personally appeared \_\_\_\_\_ known to me to be the person whose name subscribed to the foregoing instrument and acknowledged to me that he executed the same for the purposes and consideration therein expressed.

GIVEN UNDER MY HAND AND SEAL OF OFFICE this \_\_\_ day of \_\_\_\_\_, \_\_\_\_.

\_\_\_\_\_

NOTARY PUBLIC

\_\_\_\_\_

SEAL

\_\_\_\_\_

MY TERM EXPIRES

**Exhibit B**  
**CONFIDENTIALITY AGREEMENT**

**(To Be Included Submitted with Indication of Interest and Qualifications)**

This Confidentiality Agreement (the "Agreement") made and entered to as of the day of \_\_\_\_\_ 201\_, by and between the Minnesota Sports Facilities Authority ("Authority") and \_\_\_\_\_ ("Proposer") relating to the design, construction and financing of the new Minnesota Multi-Purpose Stadium (the "Project"). For purposes of this Agreement, Minnesota Vikings Football, LLC are hereinafter referred to as the "Team". The Authority and Team and each of their respective subsidiaries and affiliates are hereafter referred to individually or collectively as "Project Participants".

1. For purposes of this Agreement, "Confidential Information" means "any and all" information accessed, received, obtained or otherwise learned about the Project Participants as a result of the Project, and/or any other information whether or not designated as Confidential Information by the Project Participants. Notwithstanding the above, Confidential Information will not include any information that

- (a) is or becomes public knowledge other than by the Construction Manager's act or omission or
- (b) is or becomes available to without obligation of confidence from a source (other than the Project Participants) having the legal right to disclose that information.

2. Without the prior written consent of the Project Participants, which may be given or withheld in their sole and absolute discretion, the Proposer will (a) not disclose any Confidential Information to any third party nor give any third party access thereto, and (b) only disclose the Confidential Information to those of its employees or agents who need to know such information for purposes of completing the Project and who are bound by confidentiality obligations no less restrictive than this Agreement. For the avoidance of doubt, any disclosure by the Project Participants of work product received from the Proposer shall not be considered a breach of this Agreement.

3. The Proposer will use at least the same degree of care to avoid the publication, disclosure, reproduction or other dissemination of the Confidential Information as employed with respect to its own valuable, proprietary information which it protects from unauthorized publication, disclosure, reproduction or other dissemination and in no event, shall the Construction Manager use less than reasonable care.

4. If the Proposer receives notice that it may be required or ordered to disclose any Confidential Information in connection with legal proceedings or pursuant to a subpoena, order or a requirement or an official request issued by a court of competent jurisdiction or by a judicial, administrative, legislative, regulatory or self-regulating authority or body, the Proposer shall (a) first give written notice of the intended disclosure to the Project Participants as far in advance of disclosure as is practicable and in any case within a reasonable time prior to the time when disclosure is to be made,

(b) consult with the Project Participants on the advisability of taking steps to resist or narrow such request and (c) if disclosure is required or deemed advisable, cooperate with the Project Participants in any attempt made to obtain an order or other reliable assurance that confidential treatment will be accorded to designated portions of the Confidential Information or that the Confidential Information will otherwise be held in the strictest confidence to the fullest extent permitted under the laws, rules or regulations of any other applicable governing body.

5. The Proposer acknowledges that the unauthorized disclosure or use of Confidential Information could cause irreparable harm and significant injury, the precise measure of which maybe difficult to ascertain. Accordingly, the Proposer agrees that the Project Participants will be entitled to specific performance and injunctive or other equitable relief, without bond, as a remedy for any such breach or threatened breach, in addition to all other rights and remedies to which the Project Participants may have. The Proposer will, except to the extent inconsistent with (a) its use in connection with legal proceedings or (b) applicable law, regulations, rules or official requests, at the Authority's election, destroy or return to the Project Participants any tangible copies of the Confidential Information and permanently delete all electronic copies of the Confidential Information in its possession or control, if any, at the earlier of the request of the Project Participants or the completion of the Project and will certify in writing to the Project Participants that it has completed the forgoing.

2. In the event of any litigation between the Project Participants and the Proposer in connection with this Confidentiality Agreement, the unsuccessful party to such litigation will pay to the successful party therein all costs and expenses, including but not limited to actual attorneys' fees incurred

therein by such successful party, which costs, expenses and attorneys' fees shall be included as a part of any judgment rendered in such action in addition to any other relief to which the successful party may be entitled.

3. All references to the Proposer herein also include any of its officers, directors, employees, attorneys, agents, professional advisors and independent contractors and any person, corporation, partnership or other entity which, directly or indirectly, controls, is controlled by, or is under common control with, the undersigned. This Agreement supersedes all previous agreements, written or oral, relating to the above subject matter, and may be modified only by a written instrument duly executed by the parties hereto. All clauses and covenants contained in this Agreement are severable and, in the event, any of them is held to be invalid by any court, this Agreement will be interpreted as if such invalid clauses and covenants were not contained herein. The Proposer represents and warrants that it has the right and authority to enter into and perform this Agreement. This Agreement may not be assigned without the Project Participants' prior written consent (in their sole discretion). This Agreement shall be construed in accordance with the internal laws of the State of Minnesota, USA, without regard to its principles of conflicts of laws. None of the provisions of this Agreement can be waived or modified except expressly in writing by the parties hereto.

Dated and effective this \_\_\_\_\_ day of \_\_\_\_\_, 201\_

\_\_\_\_\_  
("Authority")

\_\_\_\_\_  
("Proposer")

{SEAL

WITNESS:

\_\_\_\_\_

(If Proposer is a Corporation, complete below)

By: \_\_\_\_\_

Title: \_\_\_\_\_

Attest: \_\_\_\_\_

Title: \_\_\_\_\_

**EXHIBIT C**

**NON-COLLUSION AFFIDAVIT**

[PROJECT NAME]

[PROJECT NUMBER]

I, \_\_\_\_\_(Name), being first duly sworn, state that I am the  
\_\_\_\_\_ (office held) of \_\_\_\_\_ (name of Bidder).

I executed this bid having full authority to do so. I certify that Bidder has not, directly or indirectly, entered into any agreement, participated in any collusion, or otherwise taken any action in restraint of free competitive bidding in connection with the above-named project. No person or persons, natural or corporate, has, have, or will receive, directly or indirectly, any rebate, fee, gift, commission, or other thing of value in consideration for this offer.

\_\_\_\_\_  
Signature

Subscribed and sworn to before me  
this \_\_\_\_ day of \_\_\_\_\_, 20\_\_\_\_.

\_\_\_\_\_  
Notary Public

**EXHIBIT D**



**State of Minnesota/Metropolitan Agencies – MDHR Certificate of Compliance**

The Request for Proposals or Request for Bids solicitation you responded to may require you to have or to obtain a Certificate of Compliance from the Minnesota Department of Human Rights (MDHR). Please fill out and submit this form with supporting documentation. The bid-award agency will not review your proposal or bid until MDHR and the bid-award agency review this form and/or supporting documentation.

**Option A** – We have employed more than 40 full-time employees on any single day in any state during the previous 12 months. Please check the applicable box below.

We have a MDHR Certificate of Compliance. Attached is the Certificate.

We don't have a MDHR Certificate of Compliance. Attached is our application for a MDHR Certificate of Compliance.

**Option B** – We have an affirmative action plan approved by the Federal Government but no MDHR Certificate of Compliance. Please check the box below.

Attached is a copy of the affirmative action plan approved by the Federal government in the last 12 months, the Federal government's approval letter, and our application for a MDHR Certificate of Compliance.

**Option C** – We are exempt because we employed fewer than 40 full-time employees on any single day in any state during the previous 12 months. Please check the box below.

We are exempt. Attached is a list of all of our employees and their state of employment during the past 12 months.

**Option D** – The current bid is exempt. The bid award agency doesn't expect the goods or services provided will exceed \$100,000.

The bid proposal is exempt. The bid project number is: \_\_\_\_\_.

**Signature**

In signing this document, you certify that the information is accurate and that you are authorized to sign on behalf of the company.

Name of Company	Authorized Signature
Date	Printed Name
Phone Number	Title

**EXHIBIT E**

**Construction Documents**

**EXHIBIT F**

NEW MINNESOTA MULTI PURPOSE STADIUM  
ACKNOWLEDGEMENT AND ATTESTATION FORM  
(To Be Submitted with Proposal)

In submitting a Proposal, the undersigned has certified that the Proposer has reviewed the Request for \_\_\_\_\_ Proposal ("RFP") dated \_\_\_\_\_ and is familiar with the terms and conditions therein and accepts and waives any protest of the terms and conditions imposed under the RFP and all documents identified therein.

The Proposer understands the Authority and Team reserve the right to reject any or all proposals in accordance with its best interest. The Proposer submitting a response does so at its own expense. I hereby certify that the foregoing is true and correct.

Proposer's Name: \_\_\_\_\_ (Company)  
Name: \_\_\_\_\_ (Officer of Company)  
Title: \_\_\_\_\_  
Date: \_\_\_\_\_

Witness: \_\_\_\_\_  
Name: \_\_\_\_\_  
Date: \_\_\_\_\_

Note: Use full corporate name and attach corporate seal, if any, here. {SEAL}



Item	Qty	Brand	Model Number	Notes	Locations
Double Shelf Heat Slide	2	Hatco	GRSDS-36D	Add stainless side panels in place of glass. Add flip up plexi door in front. Nema 5-20p plug.	118 Flex
Vent less Fryer	3	Wells	WVAE-55F		129 Mill City
Dough Sheeter	1	Somerset	CDR-500	Item shall have the following modifications: Adjustable 4" legs, synthetic rollers, and be single phase 115v/60hz	Main Kitchen
Portable Fry Holding Station	4	Hatco	GRFHS-26	Table top fry dump station with fry scoop holder and additional (2) sectional dividers for each unit. Nema 5-15p plug.	129 Mill City & 118 Flex
Portable Bar	4	TABCO	AMD-5B	61" Heavy Duty Portable Bar w/ Stainless steel doors and interior. Top and front should be upgraded to stainless steel. Item to include ice bin with drain and shut off valve, perimeter bumpers, 6" heavy duty caster with swivel and at least 2 brakes.	118 Flex Stand



# Glo-Ray® Slant Merchandising Display Warmers

Models: GRSDS-24, -30, -36, -41, -52, -60 GRSDS-24D, -30D, -36D, -41D, -52D, -60D  
GRSDS-24T, -36T

## SLANT DUAL SHELF

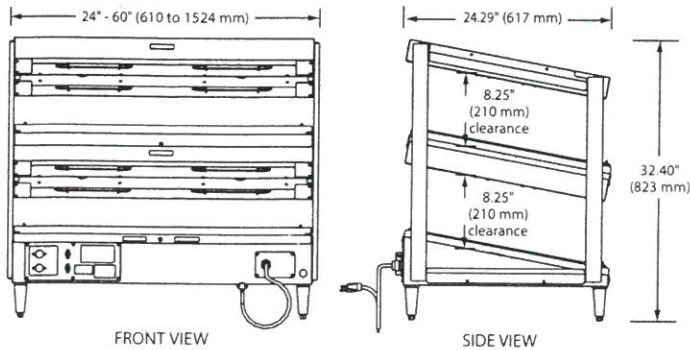

## SPECIFICATIONS Dual Shelf — SLANT MERCHANDISING DISPLAY WARMERS

The shaded areas contain electrical information for International models

Model	No. of Bulbs, Divider Rods	Dimensions (W x D x H) Height includes 4" (102 mm) legs	Usable Heated Shelf Space (W x D)	Average Chute Width	Volts	Watts	Amps	Plug	Ship Weight*
GRSDS-24D	4, 10	24" x 24.29" x 32.40" (610 x 617 x 823 mm)	22.59" x 21" (573 x 533 mm)	3.75" (95 mm)	120	1355	11.3	NEMA 5-15P	115 lbs. (52 kg)
					220	1260	5.7	CEE 7/7 Schuko	
					240	1502	6.3	BS-1363	115 lbs. (52 kg)
					220-230 (CE)	1260-1378	5.7-6.0	CEE 7/7 Schuko	
GRSDS-30D	4, 12	30" x 24.29" x 32.40" (762 x 617 x 823 mm)	28.59" x 21" (726 x 533 mm)	4.25" (108 mm)	120	1530	12.8	NEMA 5-20P <sup>†</sup>	140 lbs. (64 kg)
					220	1419	6.5	CEE 7/7 Schuko	140 lbs. (64 kg)
					240	1690	7.0	BS-1363	
					220-230 (CE)	1419-1552	6.5-6.8	CEE 7/7 Schuko	
GRSDS-36D	4, 14	36" x 24.29" x 32.40" (914 x 617 x 823 mm)	34.59" x 21" (878 x 533 mm)	4.5" (114 mm)	120	1810	15.1	NEMA 5-20P	
					220	1669	7.6	CEE 7/7 Schuko	160 lbs. (73 kg)
					240	1990	8.3	BS-1363	
					220-230 (CE)	1669-1827	7.6-7.9	CEE 7/7 Schuko	
GRSDS-41D	6, 16	41" x 24.29" x 32.40" (1041 x 617 x 823 mm)	39.59" x 21" (1005 x 533 mm)	4.5" (114 mm)	120	1090/1030	9.1/8.6	NEMA 5-15P <sup>‡</sup>	
					120/208-240	2120	9.1	NEMA L14-20P	
					220	1951	8.9	CEE 7/7 Schuko	180 lbs. (82 kg)
					240	2325	9.7	BS-1363	
220-230 (CE)	1951-2135	8.9-9.3	CEE 7/7 Schuko						
GRSDS-52D	8, 20	52" x 24.29" x 32.40" (1321 x 617 x 823 mm)	50.59" x 21" (1284 x 533 mm)	4.63" (117 mm)	120	1400/1325	11.7/11.0	NEMA 5-15P <sup>‡</sup>	215 lbs. (98 kg)
					120/208-240	2725	11.7	NEMA L14-20P	
					220	2483	11.3	CEE 7/7 Schuko	215 lbs. (98 kg)
					240	2960	12.3	BS-1363	
220-230 (CE)	2483-2718	11.3-11.8	CEE 7/7 Schuko						
GRSDS-60D	10, 24	60" x 24.29" x 32.40" (1524 x 617 x 823 mm)	58.59" x 21" (1488 x 533 mm)	4.5" (114 mm)	120/208-240	3340	14.3	NEMA L14-20P	238 lbs. (108 kg)
					220	3240	14.7	CEE 7/7 Schuko	238 lbs. (108 kg)
					240	3340	13.9	No Plug	
					220-230 (CE)	3240-3541	14.7-15.4	CEE 7/7 Schuko	
230-240 (CE)	3067-3340	13.3-13.9	No Plug						

\* Shipping weight includes packaging.

† Canada, use NEMA 5-20P.

‡ Not available for Canada, has two NEMA 5-15P power cords.

HATCO CORPORATION | P.O. Box 340500 Milwaukee, WI 53234-0500 U.S.A.

(800) 558-0607 | (414) 671-6350 | www.hatcocorp.com | equipsales@hatcocorp.com | intlsales@hatcocorp.com

# WVAE-55F, WVAE-55FS VENTLESS FRYER



WVAE-55F, WVAE-55FS VENTLESS FRYER

## Features

- **Ventless Hood System** exceeds EPA Standard 202 for the release of particulate matter.
- **Air Filter Interlock System** will not allow heating element to be energized if the baffle or HEPA filter is not in place.
- **Airflow Sensing System** is designed to monitor airflow through the filtration system to optimize grease removal efficiency.
- **The system warning light** will indicate when the HEPA filter needs to be replaced.
- **Ansul R-102 Fire Suppression** is built into the Ventless Hood using a unique anti-fire design.
- **The solid state control** on the WVAE-55FS incorporates a seven key programmable time and temperature menu.
- **Repeat cycle timer** activates using one push button operation.
- **Paperless filtration system** reduces labor and cleans oil more efficiently, and combined with Flavor Saver Filter Powder will **substantially increase oil life**.
- **Automatic basket lift cradle** raises basket above oil at end of timed cook cycle, maximizing handling safety.
- **Flat bar elements**, located below the basket, are heavy-duty stainless steel with a low watt density for longer oil life.
- **Frypot** is constructed of stainless steel and robotically welded for durability.
- **The WVAE-55F and WVAE-55FS fryers** are Underwriters Laboratories, Inc. LISTED and meet NSF International standards.
- **A one-year warranty** against defects covers parts and labor.

## Specifications

Overall Dimensions:	Inches	MM
Width	15 13/16	401
Depth	43 11/16	1110
Height (incl. 4" legs)	76 3/8	1940
Oil Capacity:	Lbs.	KG
WVAE-55F/FS	55	25
Typical Production:	Lbs.	KG
Chicken <i>frozen</i>	25*	11
Chicken <i>fresh</i>	33*	15
*With standard basket only		
Weights:	Lbs.	KG
Installed	425	193
Shipping	525	238

## Export

The following models are available for export and meet the standards for CE:

- WVAE-55FEU, 380-415VAC, 3Ø, 17400 watts
- WVAE-55FSEU, 380-415VAC, 3Ø, 17400 watts

## Accessories / Options

- HEPA Filter, fits all ventless fryers, 22402
- Charcoal Filter, fits all ventless fryers, 22403
- Flavor Saver Oil Filter Powder, 45 packs, 22410
- Rear Leg Kit, for remote pull, 22692
- Half-Size Baskets Available

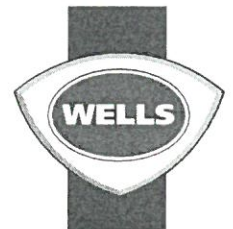



LISTED  
E146882



STD.4



LISTED  
E146882



EXPORT  
MODELS  
ONLY

## MODEL WVAE-55F FRYERS

### DIMENSIONS:

INCH  
(MM)

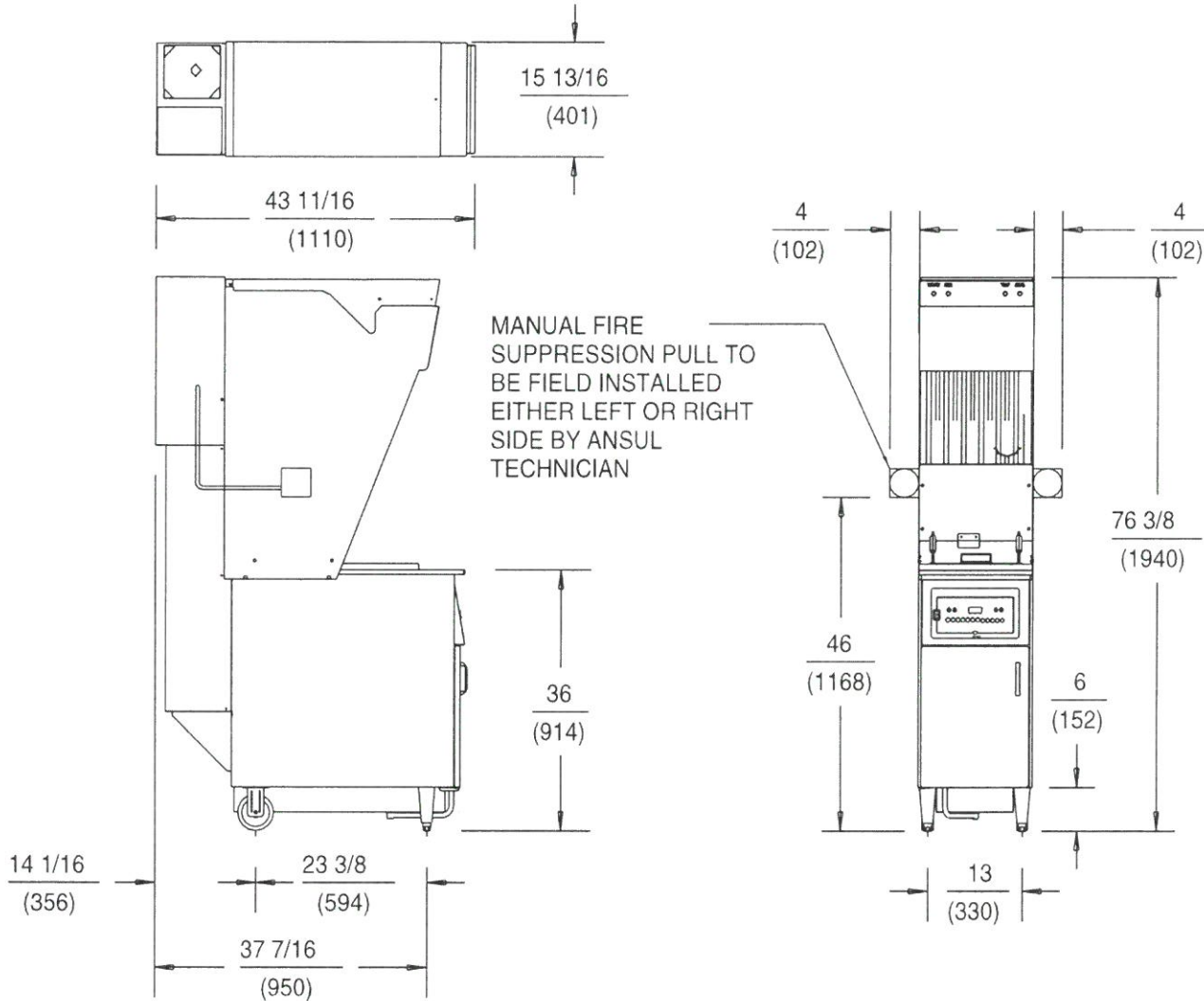

### WVAE-55F ELECTRICAL SPECIFICATIONS:

MODELS	VOLTS	WATTS	AMPS PER LINE PHASE 3				AMPS SINGLE PHASE	POWER SUPPLY CORD
			L1	L2	L3	N		
WVAE-55F	208	17000	47.8	47.2	47.8	NA	NA	NONE
WVAE-55F	240	17000	41.5	41.0	41.5	NA	NA	NONE
Ⓢ WVAE-55FEU	380-415	17400	26.0	24.0	24.0	3.0	NA	NONE

All models with an 'S' suffix have the same electrical specifications as the standard units.

NOTE: Specifications are subject to change without notice. Ⓢ Denotes export (EU) products.

SPECIAL ENVIRONMENTAL NOTICE: The hood system is designed to reduce odor emissions but will not eliminate odors. Air exchange at the installation site must comply with requirements of the local jurisdictional authority. To ensure dilution of odor build-up, minimum recommendation is 400 cubic feet of fresh air per minute both in and out of the area.

WELLS MANUFACTURING COMPANY

2 ERIK CIRCLE, PO BOX 280, VERDI, NV 89439 U.S.A. • USA PHONE: (775) 689-5700 • FAX: (775) 689-5972

FOR ORDERS ONLY: (888) 356-5362 • FAX: (800) 356-5142 • www.wellsbloomfield.com

©2001 WELLS MANUFACTURING • PRINTED IN THE U.S.A. • 03/01 • REV(C) • PART NO. 302022

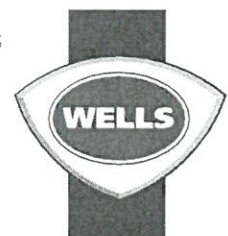



# Glo-Ray® Fry Holding Station

Models: GRFHS-16, -21, -22, -26, -PTT21, -PT16, -PT26

## GRFHS-16, -21, -22, -26

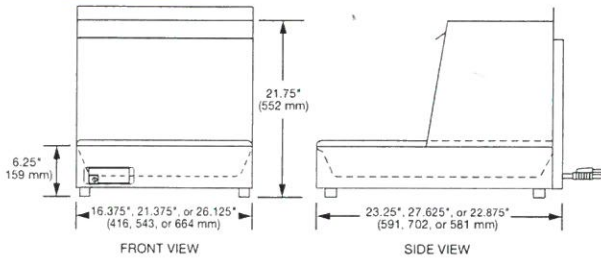

## GRFHS-PTT21

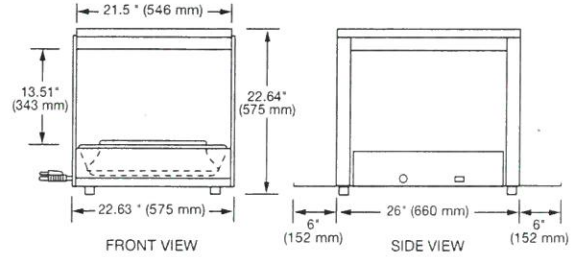

## GRFHS-PT16, -PT26

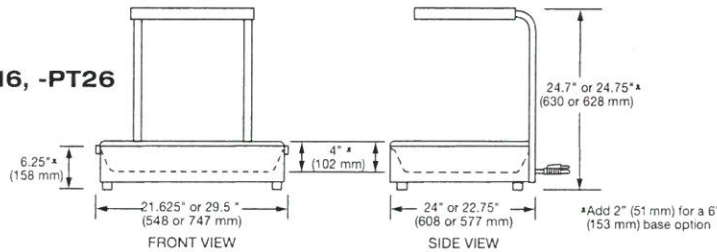

## SPECIFICATIONS Glo-Ray Fry Holding Station

The shaded areas contain electrical information for International models only

Model	Dimensions (Width x Depth x Height)	Volts	Phase	Watts	Amps	Plug	Ship Weight*
GRFHS-16	16.38" x 23.21" x 22.75" (416 x 590 x 577 mm)	100	Single	878	8.8	NEMA 5-15P	63 lbs. (29 kg)
		120		1090	9.1	NEMA 5-15P	
		220-230 (CE)		1057-1155	4.8-5.0	CEE 7/7 Schuko	
		230-240 (CE)		1019-1110	4.4-4.6	BS-1363 or AS 3112*	
GRFHS-PT16	21.58" x 23.95" x 24.875" (548 x 608 x 632 mm)	120	Single	1090	9.1	NEMA 5-15P	60 lbs. (27 kg)
GRFHS-21	21.37" x 27.58" x 22.75" (543 x 701 x 577 mm)	100	Single	1007	10.1	NEMA 5-15P	63 lbs. (29 kg)
		120		1200	10.0	NEMA 5-15P	
		220-230 (CE)		1218-1332	5.5-5.8	CEE 7/7 Schuko	
		230-240 (CE)		1102-1200	4.8-5.0	BS-1363 or AS 3112*	
GRFHS-PTT21	22.63" x 38" x 22.64" (575 x 965 x 575 mm)	120	Single	1740	14.5	NEMA 5-15P†	100 lbs. (45 kg)
		220-230 (CE)		1486-1624	6.8-7.1	CEE 7/7 Schuko	
		230-240 (CE)		1624-1768	7.1-7.4	BS-1363 or AS 3112*	
GRFHS-22	22" x 18.5" x 17.25" (559 x 470 x 439 mm)	120	Single	1030	8.6	NEMA 5-15P	44 lbs. (20 kg)
GRFHS-26	26.1" x 22.86" x 21.75" (663 x 581 x 553 mm)	100	Single	1007	10.1	NEMA 5-15P	66 lbs. (30 kg)
		120		1200	10.0	NEMA 5-15P	
		220-230 (CE)		1243-1359	5.7-5.9	CEE 7/7 Schuko	
		230-240 (CE)		1128-1229	4.9-5.1	BS-1363 or AS 3112*	
GRFHS-PT26	29.4" x 22.71" x 24.71" (747 x 577 x 628 mm)	120	Single	1440	12.0	NEMA 5-15P	64 lbs (29 kg)
		220-230 (CE)		1233-1347	5.6-5.9	CEE 7/7 Schuko	
		230-240 (CE)		1347-1468	5.9-6.1	BS-1363 or AS 3112*	

\* Shipping weight includes packaging.

† AS3112 plug for use in Australia only.

‡ The GRFHS-PTT21 for Canada uses a NEMA 5-20P plug configuration.

### CORD LOCATION

GRFHS-16, -21, -26, -PT26: Back side, lower right corner.

GRFHS-PTT21: Lower right-hand side.

### PLUG CONFIGURATIONS

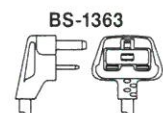
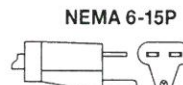
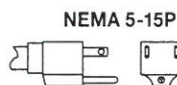

### PRODUCT SPECS

#### Glo-Ray® Fry Holding Station

The Glo-Ray Fry Holding Station shall be a Glo-Ray® Model ... as manufactured by the Hatco Corporation, Milwaukee, WI 53234 U.S.A.

The Fry Holding Station shall be rated at ... watts, ... volts, and be ... inches (millimeters) in overall width. It shall consist of either a stainless steel housing or an

aluminum housing with ceramic. Pre-set thermostatically controlled based heat. Portable warmer features wire guards, shatter-resistant incandescent display lights, a lighted on-off switch, and 6' (1829 mm) cord and plug.

Comes with 24/7 parts and service assistance (U.S. and Canada only).

HATCO CORPORATION | P.O. Box 340500 Milwaukee, WI 53234-0500 U.S.A. | (800) 558-0607 | (414) 671-6350

Fax: (800) 543-7521 | Int'l. Fax: (414) 671-3976 | www.hatcocorp.com | email: equipsales@hatcocorp.com



Project \_\_\_\_\_

Item # \_\_\_\_\_

Quantity \_\_\_\_\_

## Glo-Ray® Fry Holding Station

Models: GRFHS-16, -21, -22, -26, -PTT21, -PT16, -PT26

Hatco offers convenient Glo-Ray® Fry Holding Stations that can be placed where they are most needed - next to a fryer! Glo-Ray heat technology offers you the ability to keep fried foods at optimum temperatures, ready to serve, without cooking or drying them out.

### Standard features

- Ceramic heating elements above, allowing ample space between the warmer and food bin to empty baskets
- Pre-set thermostatically-controlled heated base maintains uniform holding temperatures from below
- Various hardcoated fry ribbons stage boxed or bagged products for quick service areas
- PT and PTT models are pass-through style
- Sectional divider permits holding of multiple products
- Models have 16.75", 18", or 20" (425, 457, or 508 mm) clearances
- Bottom trivet lifts food off the bottom of the station promoting air movement and reduces the build up of moisture
- Pass-thru tunnel is available with model GRFHS-PTT21

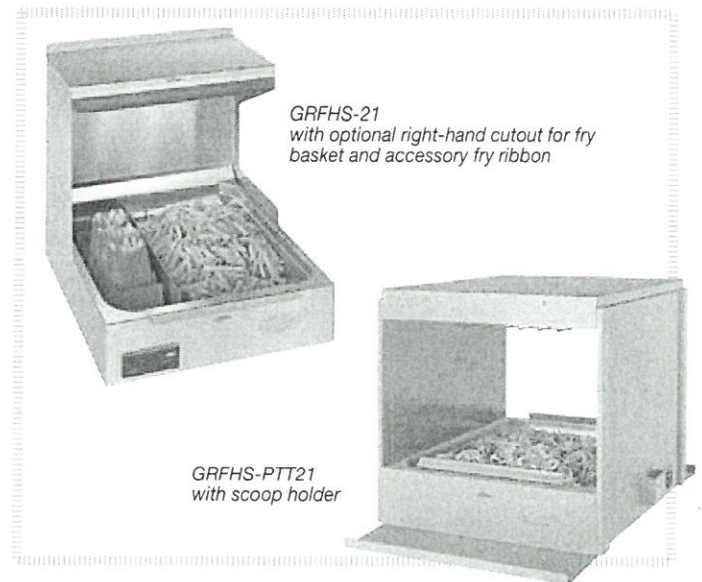

### Options (available at time of purchase only)

- Halogen Bulb in lieu of Standard Display Light (60 watt)
- Left or Right side Cutout (GRFHS-16, -21, and -26) (Adds 1.7"(43 mm) to width of unit)
- 6" (15 mm) deep pan (GRFHS-PT26)

### Accessories

- 4 Pleat Hardcoated Fry Box Ribbon (GRFHS-16 & -26)
- 5 Pleat Hardcoated Fry Bag Ribbon (GRFHS-16 & -26)
- 5 Pleat Hardcoated Fry Box Ribbon (GRFHS-21)
- 6 Pleat Hardcoated Fry Box/Bag Combo Ribbon (GRFHS-21)
- 7 Pleat Hardcoated Fry Bag Ribbon (GRFHS-21)
- 8 Pleat Hardcoated French Fry Bag Ribbon
- 8 Pleat Hardcoated Fry Box Ribbon (GRFHS-PT26 & PTT21)
- 9 Pleat Hardcoated Fry Box/Bag Combo Ribbon (GRFHS-PT26 & PTT21)
- 10 Pleat Hardcoated Fry Bag Ribbon (GRFHS-PT26 & PTT21)
- Additional Sectional Dividers (one standard per unit)
- 5" (127 mm) side-by-side bag holder (GRFHS-21)
- 5" (127 mm) piggy back bag holder (GRFHS-21 & -PTT21)
- Scoop Holder - adds 1.25" (32 mm) to overall product width for each scoop holder (one standard on GRFHS-PT26, -PTT21) (not available for the GRFHS-22)
- Food Pans (not available for the GRFHS-22)
- Wire Trivet (not available for the GRFHS-22)



HATCO CORPORATION | P.O. Box 340500 Milwaukee, WI 53234-0500 U.S.A. | (800) 558-0607 | (414) 671-6350  
 Fax: (800) 543-7521 | Int'l. Fax: (414) 671-3976 | www.hatcocorp.com | email: equipsales@hatcocorp.com



Project \_\_\_\_\_

Item # \_\_\_\_\_

Quantity \_\_\_\_\_

# Glo-Ray® Slant Merchandising Display Warmers

Models: GRSDS-24, -30, -36, -41, -52, -60

**GRSDS-24D, -30D, -36D, -41D, -52D, -60D**

GRSDS-24T, -36T

Hatco's Glo-Ray® Slant Merchandising Display Warmers are designed specifically to hold hot wrapped or boxed product safely, and at proper serving temperatures. With pre-focused infrared top heat and a thermostatically-controlled hardcoated heated base, they excel at extending the holding times of most food, offering the convenience of self-serve and the efficiency of kitchen-to-server holding.

## Standard features

- Shelves are slanted for the convenience of self-service
- Models have pre-focused infrared top heat directing heat to the outer edges of the holding surface where heat loss is the greatest
- Thermostatically-controlled, hardcoated heated base has a temperature range of 185°- 200°F (85°- 93°C)
- Coated shatter-resistant incandescent lights enhance product display while safeguarding food products from bulb breakage
- NSF require units over 36" (914 mm) in width or weighing more than 80 lbs. (36 kg) to be either sealed, or raised on the installation surface with the 4" (102 mm) legs included
- Standard units shipped with: tempered glass side panels, hardcoated shelves, coated shatter-resistant incandescent lights, adjustable dividers, 4" (102 mm) legs, and a 6' (1829 mm) cord with plug

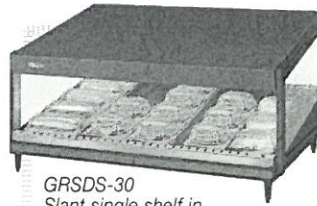

GRSDS-30  
Slant single shelf in  
optional Designer Black



GRSDS-24D  
Slant dual shelf

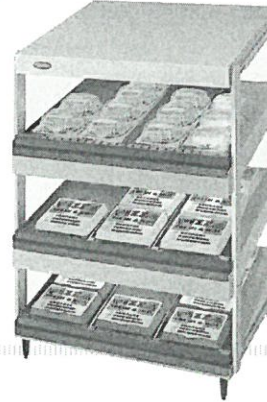

GRSDS-24T  
Slant triple shelf

## Options (available at time of purchase only)

### Designer Colors

- Non-standard colors are non-returnable – Glossy Gray standard
- Warm Red    Black    Gray Granite    White Granite  
 Navy Blue    Hunter Green    Antique Copper

LED Indicating Temperature Control

**Stainless Steel End Panels in lieu of Glass End Panels**

5" (127 mm) Sneeze Guard (customer side only)

- 24" ( 609 mm) model    30" ( 762 mm) model  
 36" ( 914 mm) model    41" (1041 mm) model  
 52" (1321 mm) model    60" (1524 mm) model

Halogen Bulb (60 watt) in lieu of Standard Display Light (not available for export voltages)

Flip-up Door Locking Plate

Display Sign Holder (signs not included) Color Matches Unit Color

- Top or Intermediate Shelf

- 24" ( 609 mm) model    30" ( 762 mm) model  
 36" ( 914 mm) model    41" (1041 mm) model  
 52" (1321 mm) model    60" (1524 mm) model

## Accessories

4" (102 mm) Adjustable Legs

(Standard on models GRSDS-36 and larger, and all dual models)

**Plexi-Glass Flip-Up doors on one side - Not compatible with optional sneeze guards in same opening (one side only)**

- 24" ( 609 mm) model    30" ( 762 mm) model  
 36" ( 914 mm) model    41" (1041 mm) model

52" (1321 mm) model, split doors    60" (1524 mm) model, split door

Additional Stainless Steel Divider Rods



HATCO CORPORATION | P.O. Box 340500 Milwaukee, WI 53234-0500 U.S.A.

(800) 558-0607 | (414) 671-6350 | www.hatcocorp.com | equipsales@hatcocorp.com | intl@hatcocorp.com

# SOMERSET

## DOUGH SHEETER

### CDR-500

CDR-500 SYNTHETIC ROLLERS

CDR-500M METALLIC ROLLERS

### FEATURES

- Simple handle adjustments for exact uniform dough thickness
- Synthetic rollers eliminate dough build up
- Safety sensors for automatic shutoff
- Compact design, ideal for use in limited space
- Ergonomic design for easy operation
- Convenient side operation
- Maintenance free drive mechanism
- Drive mechanism isolated from roller area
- Safe, simple, easy to operate, easy to clean
- Sanitary, heavy duty, all stainless steel welded construction
- Spring loaded scrapers readily removable for easy cleaning



CDR-500F with tray

### INDUSTRY USES:

- Bakeries
- Donut Shops
- Institutions
- Schools
- Hospitals
- Pizzerias

### SPECIFICATIONS

(Specifications subject to change without notice)

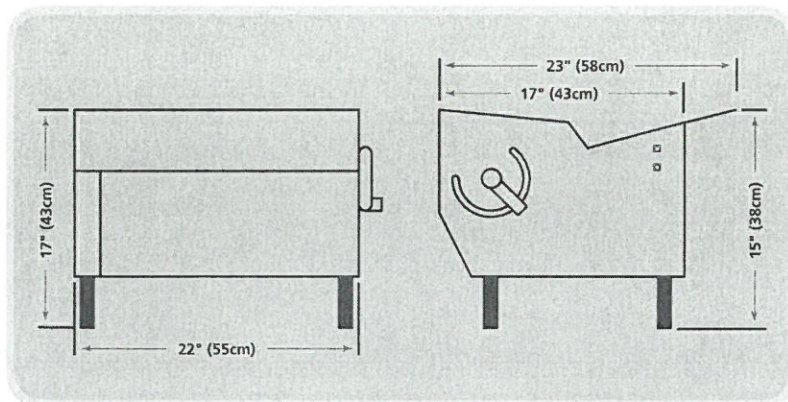

**Rollers:** 3.5" dia. by 20" length  
(8.89 cm dia. by 50.80 cm length)

**Scrapers:** Synthetic, Spring Loaded, Removable

**Bearings:** Sealed Ball Bearings, Permanently Lubricated

**Gear Motor:** Heavy Duty 3/4 HP, Maintenance Free, Single Phase, 115v/60Hz or 220v/50Hz

**Finishing:** All Stainless Steel

**Legs:** 4" Adjustable, Stainless Steel

**Shipping Weight:** 150 lbs (68 kgs)



MADE IN THE U.S.A. 05.10.12



# SOMERSET

Tel: 978.667.3355  
800.772.4404

Fax: 978.671.9466

Email: somerset@smrset.com

[www.smrset.com](http://www.smrset.com)



## CDR-500

## DOUGH SHEETER

### **IDEAL FOR:**

- Cinnamon Rolls
- Yeast Raised Donuts
- Danishes
- Pastry Production
- Dough Lamination
- Pie Crusts
- Pizza
- Pasta
- Fondant

### **HIGHLIGHTS:**

- Sheets dough up to 20" (51cm wide)
- Ships standard with synthetic, non-stick rollers
- Sheets 500-600pcs. per hour
- Ergonomic design makes it easy and simple to operate
- All stainless steel construction offers safety, sanitation, speed, simplicity, durability, and low cost

*The most versatile tabletop sheeter available!*

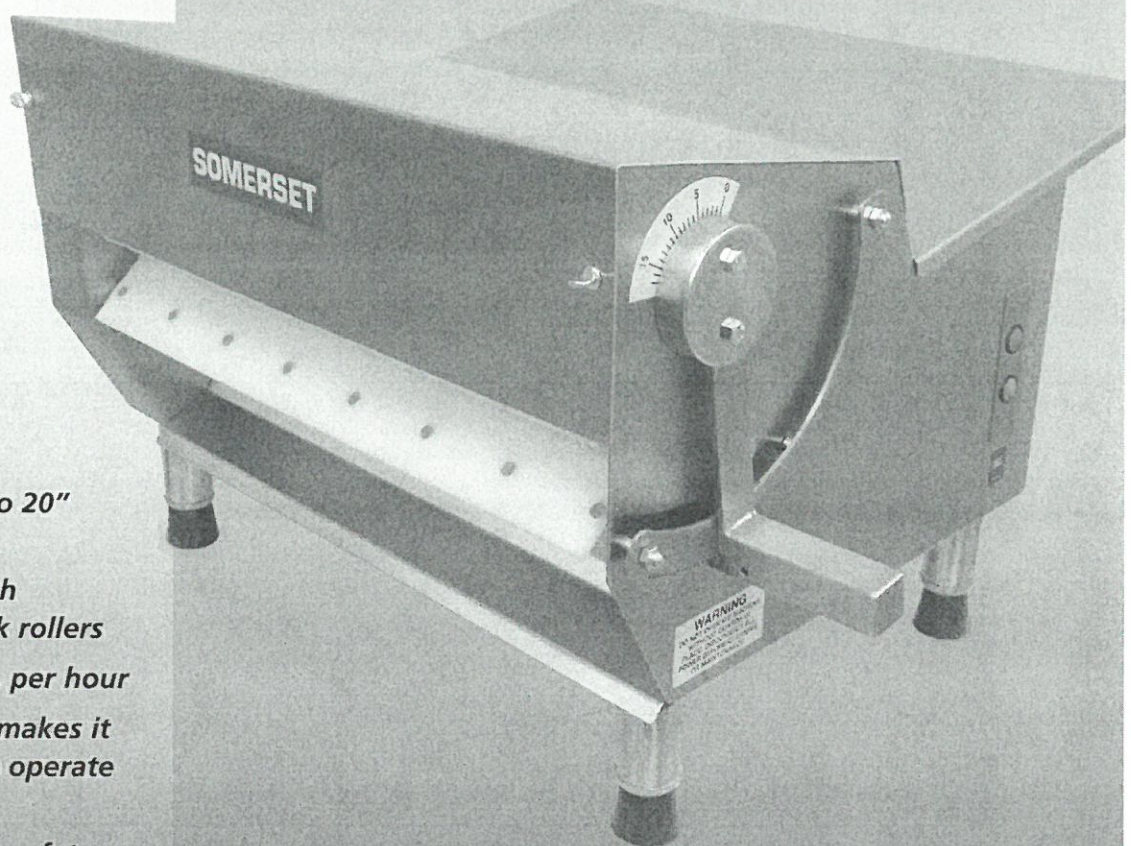

*The ultimate sheeter! Sheets dough to a uniformed thickness in seconds!*

SOMERSET INDUSTRIES, INC • 1 ESQUIRE ROAD • NORTH BILLERICA, MA 01862 • U.S.A.



# HEAVY DUTY PORTABLE BAR WITH STAINLESS STEEL INTERIOR

## FEATURES:

- All Stainless Steel Interior
- 19" x 13-1/2" x 11" insulated ice bin. Complete with drain & shut-off valve
- Full perimeter bumpers
- 4 - 6" Heavy Duty Swivel Casters, 2 with brakes

## MATERIAL:

- TOP & FRONT:** Mica Laminate, black finish
- UNIT:** Stainless Steel work top, back, sides & bottom
- WORK AREA:** Stainless Steel
- CASTERS:** Rubber
- SPEED RAILS:** Stainless Steel

Item #:	_____	Qty #:	_____
Model #:	_____		
Project #:	_____		

**DESIGNED FOR HEAVY-DUTY USE**

**Custom Colors Available!  
(Exterior Only. See below for details)**

ALL STAINLESS STEEL INTERIOR! Upgrade for Stainless Steel Front Available.

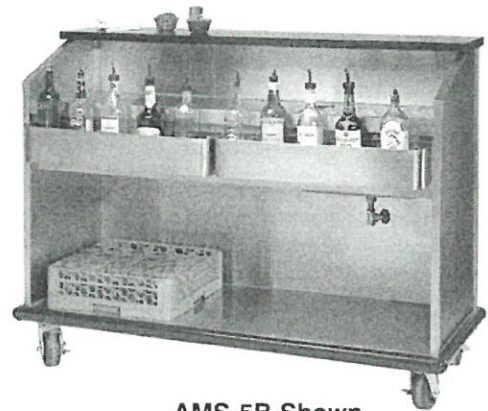

AMS-5B Shown

Model #	Size L x W x H	Storage Cabinet Dim.	Bar Top Width	Weight	Cubic Feet
AMS-5B	61" x 23" x 47"	58" x 21" x 18.5"	12"	315	50
AMS-6B	74" x 23" x 47"	23.5" x 21" x 27.5"	12"	350	60
UNITS WITH STAINLESS STEEL DOORS					
AMD-5B	61" x 23" x 47"	58" x 21" x 18.5"	12"	315	50
AMD-6B*	74" x 23" x 47"	23.5" x 21" x 27.5"	12"	350	60

\*Units Include Center Stainless Steel Panel For Extra Support

### Upgrade for Cold Plates Available

Add the suffix, **-7** to the model number.  
(Factory Install Only)

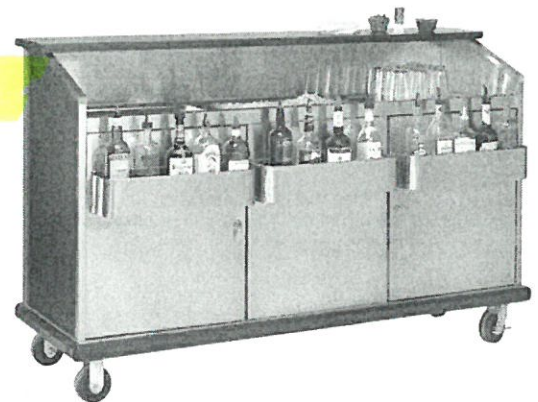

AMD-6B Shown

## Available Accessories

Custom Mica Colors - **Model SU-81**  
(Custom colors include exterior finishes only (Bar front, doors-if applicable and bar top. All interiors are standard black finish)



**Customer Service Available To Assist You 1-800-645-3166 8:30 am - 8:00 pm E.S.T.**

For Orders & Customer Service:  
Email: [customer@advancetabco.com](mailto:customer@advancetabco.com) or Fax: 631-242-6900

For Smart Fabrication™ Quotes:  
Email: [smartfab@advancetabco.com](mailto:smartfab@advancetabco.com) or Fax: 631-586-2933

# DIMENSIONS and SPECIFICATIONS

TOL ± .125"

ALL DIMENSIONS ARE TYPICAL

## AMS SERIES

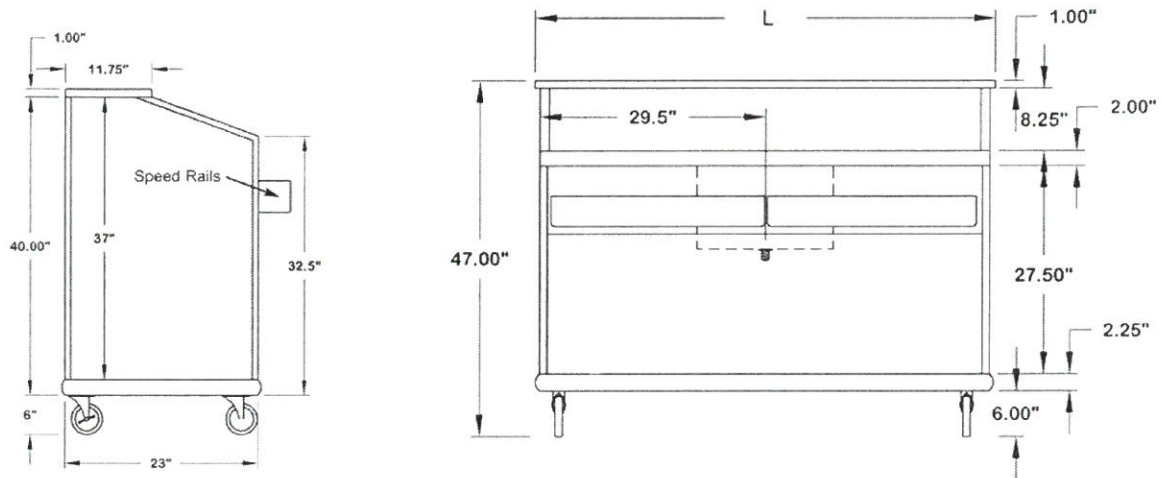

## AMD SERIES

