

ADDENDUM NO. ONE
December 12, 2014

This Addendum forms a part of the contract Documents and modifies the original plans and specifications dated December 10, 2014.

Acknowledge receipt of this Addendum on the Proposal Form. Failure to do so may subject Proposer to disqualification.

Reference made to Specifications and Drawings shall be used as a guide only. When Specification Sections or drawings are issued, changes made in Specifications or on Drawings will take precedence over narrative explanation below. Proposer shall determine for themselves the work affected by Addendum items.

This Addendum consists of 13 pages.

OWNER
MINNESOTA SPORTS FACILITIES AUTHORITY
900 SOUTH 5th STREET, MINNEAPOLIS, MN 55415

OWNER
MINNESOTA WINGS FOOTBALL, LLC
5500 VIKING DR., EDEN PRAIRIE, MN 55344

ARCHITECT / INTERIORS / BRANDING
HKS, INC.
300 N. ST. PAUL ST., SUITE 100, DALLAS, TX 75201

ASSOCIATE ARCHITECT - SKIN
STUDIO FIVE ARCHITECTS
322 FIRST AVE. N. SUITE 400, MINNEAPOLIS, MN 55401

ASSOCIATE ARCHITECT - INTERIORS
STUDIO HIVE
901 NORTH 5th ST., SUITE 228, MINNEAPOLIS, MN 55401

MEP / TECHNOLOGY / LIGHTING
M.E. ENGINEERS, INC.
10555 WEST 43rd AVE., WHEAT RIDGE, CO 80033

STRUCTURAL ENGINEER
THORNTON TOMASETTI
12750 MERIT DR., SUITE 750, LB-7, DALLAS, TX 75251

CIVIL ENGINEER
EVS, INC.
10225 VALLEY VIEW, SUITE 123, EDEN PRAIRIE, MN 55344

LANDSCAPE ARCHITECT
OSLUND AND ASSOCIATES
115 WASHINGTON AVE. N., MINNEAPOLIS, MN 55401

AUDIO VISUAL CONSULTANTS
ACOUSTIC DIMENSIONS
1508 WRIGHT BROTHERS DR., ADDISON, TX 75001

WJHW
4801 SPRING VALLEY RD., DALLAS, TX 75244

CODE / FIRE PROTECTION
FSC, INC.
6225 INDIAN CREEK, SUITE 300, OVERLAND PK, KS 66210

FOOD SERVICE
RICCA NEWMARK
5235 SOUTH VALENTIA, GREENWOOD VLG, CO 80111

WAYFINDING
SELEBY PERKINS DESIGN
432 CULVER BLVD., PLAYA DEL REY, CA 90293

VERTICAL TRANSPORTATION
ELEVATOR ADVISORY GROUP
14530 PENNOCOCK AVE., SAINT PAUL, MN 55124

ADA CONSULTANT
ED ROTHER CONSULTING, LLC
22950 MISSION BELLEVUE, LOUISBURG, KS 66603

WIND / SNOW CONSULTANT
ROWAN, WILLIAMS, DAVIES, AND IRWIN, INC.
650 WOODLAWN RD. W., QUELPH, ON CANADA N1K 1B8

BUILDING ENVELOPE CONSULTANT
THORNTON TOMASETTI - BUILDING SKIN PRACTICE
300 N. WABASH AVE., SUITE 1500, CHICAGO, IL 60611

FAÇADE ACCESS CONSULTANT
LEIGH BATES, INC.
8089 LINCOLN ST., SUITE 105, LITTLETON, CO 80122

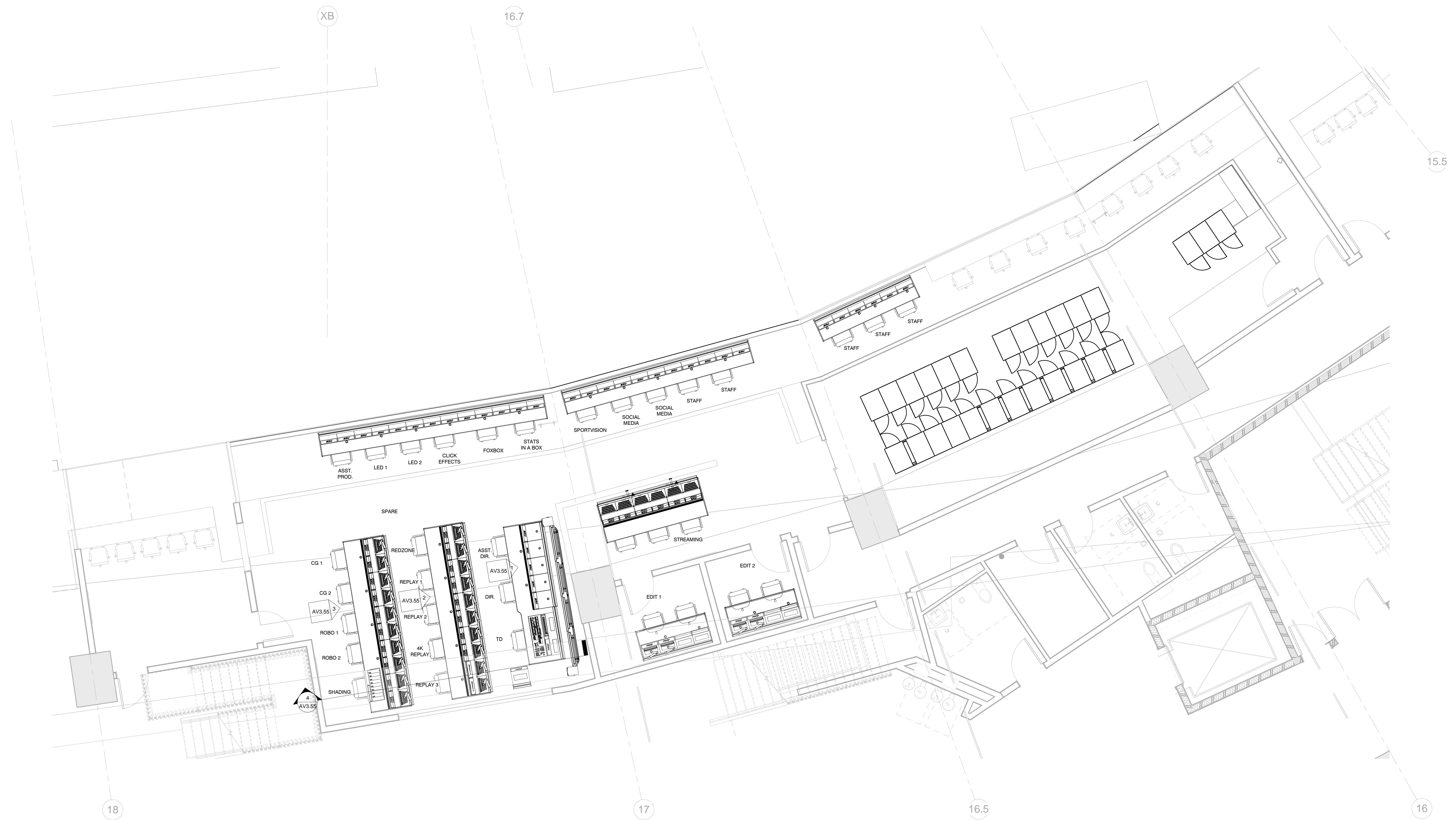

KEY PLAN

10	11	12	1
9	16	13	2
8	15	14	3
7	6	5	4

REVISION

NO.	DESCRIPTION	DATE

HKS PROJECT NUMBER
16246.000

DATE
MAY 2, 2014

ISSUE
CCD-060

SHEET TITLE
Production Control Room Console Layout

SHEET NO.
AV3.51

1 Production Control Room (PCR) Console Layout
1/4" = 1'-0"

PLOT DATE: 4/29/2014 12:29:04 PM TEMPLATE VERSION: 2/13/2012/2994

- OWNER**
MINNESOTA SPORTS FACILITIES AUTHORITY
900 SOUTH 5th STREET, MINNEAPOLIS, MN 55415
- OWNER**
MINNESOTA WINGS FOOTBALL, LLC
5500 VIKING DR., EDEN PRAIRIE, MN 55344
- ARCHITECT / INTERIORS / BRANDING**
HKS, INC.
301 N. ST. PAUL ST., SUITE 100, DALLAS, TX 75201
- ASSOCIATE ARCHITECT - SKIN**
STUDIO FIVE ARCHITECTS
322 FIRST AVE. N. SUITE 400, MINNEAPOLIS, MN 55401
- ASSOCIATE ARCHITECT - INTERIORS**
STUDIO HIVE
901 NORTH 5th ST., SUITE 228, MINNEAPOLIS, MN 55401
- MEP / TECHNOLOGY / LIGHTING**
M.E. ENGINEERS, INC.
10555 WEST 43rd AVE., WHEAT RIDGE, CO 80033
- STRUCTURAL ENGINEER**
THORNTON TOMASETTI
12750 MERIT DR., SUITE 750, LB-7, DALLAS, TX 75251
- CIVIL ENGINEER**
EVS, INC.
10225 VALLEY VIEW, SUITE 123, EDEN PRAIRIE, MN 55344
- LANDSCAPE ARCHITECT**
OSLUND AND ASSOCIATES
115 WASHINGTON AVE. N., MINNEAPOLIS, MN 55401
- AUDIO VISUAL CONSULTANTS**
ACUSTIC DIMENSIONS
1508 WRIGHT BROTHERS DR., ADDISON, TX 75001
- WJHW**
4801 SPRING VALLEY RD., DALLAS, TX 75244
- CODE / FIRE PROTECTION**
FSC, INC.
6225 INDIAN CREEK, SUITE 300, OVERLAND PK, KS 66210
- FOOD SERVICE**
RICCA NEWMARK
5235 SOUTH VALENTIA, GREENWOOD VLG, CO 80111
- WAYFINDING**
SELBERT PERKINS DESIGN
432 CULVER BLVD., PLAYA DEL REY, CA 90293
- VERTICAL TRANSPORTATION**
ELEVATOR ADVISORY GROUP
14530 PENNCOCK AVE., SAINT PAUL, MN 55124
- ADA CONSULTANT**
ED ROTHER CONSULTING, LLC
2290 MISSOURI BELLEVUE, LOUISBURG, KS 66663
- WIND / SNOW CONSULTANT**
ROWAN, WILLIAMS, DAVIES, AND IRWIN, INC.
650 WOODLAWN RD. W., GUELPH, ON CANADA N1K 1B8
- BUILDING ENVELOPE CONSULTANT**
THORNTON TOMASETTI - BUILDING SKIN PRACTICE
300 N. WABASH AVE., SUITE 1500, CHICAGO, IL 60611
- FAÇADE ACCESS CONSULTANT**
LEITCH BATES, INC.
8089 LINCOLN ST., SUITE 105, LITTLETON, CO 80122



KEY PLAN

10	11	12	1
9	16	13	2
8	15	14	3
7	6	5	4

REVISION NO.	DESCRIPTION	DATE

HKS PROJECT NUMBER
16246.000

DATE
MAY 2, 2014

ISSUE
CCD-060

SHEET TITLE
Production Control Room RCP

SHEET NO.
AV3.54

1 Production Control Room (PCR) RCP Detail
1/4" = 1'-0"

PLOT DATE: 4/29/2014 12:29:25 PM TEMPLATE VERSION: 2/13/2012/2014

OWNER
MINNESOTA SPORTS FACILITIES AUTHORITY
900 SOUTH 5th STREET, MINNEAPOLIS, MN 55415

OWNER
MINNESOTA WIKINGS FOOTBALL, LLC
5500 VIKING DR., EDEN PRAIRIE, MN 55344

ARCHITECT / INTERIORS / BRANDING
HKS, INC.
301 N. ST. PAUL, SUITE 100, DALLAS, TX 75201

ASSOCIATE ARCHITECT - SKIN
STUDIO FIVE ARCHITECTS
322 FIRST AVE. N. SUITE 400, MINNEAPOLIS, MN 55401

ASSOCIATE ARCHITECT - INTERIORS
STUDIO HIVE
901 NORTH 3rd ST., SUITE 228, MINNEAPOLIS, MN 55401

MEP / TECHNOLOGY / LIGHTING
M.E. ENGINEERS, INC.
10555 WEST 43rd AVE., WHEAT RIDGE, CO 80033

STRUCTURAL ENGINEER
THORNTON TOMASETTI
12750 MERIT DR., SUITE 750, DALLAS, TX 75251

CIVIL ENGINEER
EVS, INC.
10225 VALLEY VIEW, SUITE 123, EDEN PRAIRIE, MN 55344

LANDSCAPE ARCHITECT
OSLUND AND ASSOCIATES
115 WASHINGTON AVE. N., MINNEAPOLIS, MN 55401

AUDIO VISUAL CONSULTANTS
ACOUSTIC DIMENSIONS
15508 WRIGHT BROTHERS DR., ADDISON, TX 75001

WJHW
4801 SPRING VALLEY RD., DALLAS, TX 75244

CODE / FIRE PROTECTION
FSC, INC.
9225 INDIAN CREEK, SUITE 300, OVERLAND PK., KS 66210

FOOD SERVICE
RICCA NEWMARK
5235 SOUTH VALENTIA, GREENWOOD VLG., CO 80111

WAYFINDING
SELBERT PERKINS DESIGN
432 CULVER BLVD., PLAYA DEL REY, CA 90293

VERTICAL TRANSPORTATION
ELEVATOR ADVISORY GROUP
14530 PENNOCOCK AVE., SAINT PAUL, MN 55124

ADA CONSULTANT
ED ROTHER CONSULTING, LLC
2290 MISSION BELLEVUE, LOUISBURG, KS 66663

WIND / SNOW CONSULTANT
ROWAN, WILLIAMS, DAVIES, AND IRWIN, INC.
650 WOODLAWN RD. W., GUELPH, ON CANADA N1K 1B8

BUILDING ENVELOPE CONSULTANT
THORNTON TOMASETTI - BUILDING SKIN PRACTICE
300 N. WABASH AVE., SUITE 1500, CHICAGO, IL 60611

FAÇADE ACCESS CONSULTANT
LEIGH BATES, INC.
8089 LINCOLN ST., SUITE 105, LITTLETON, CO 80122

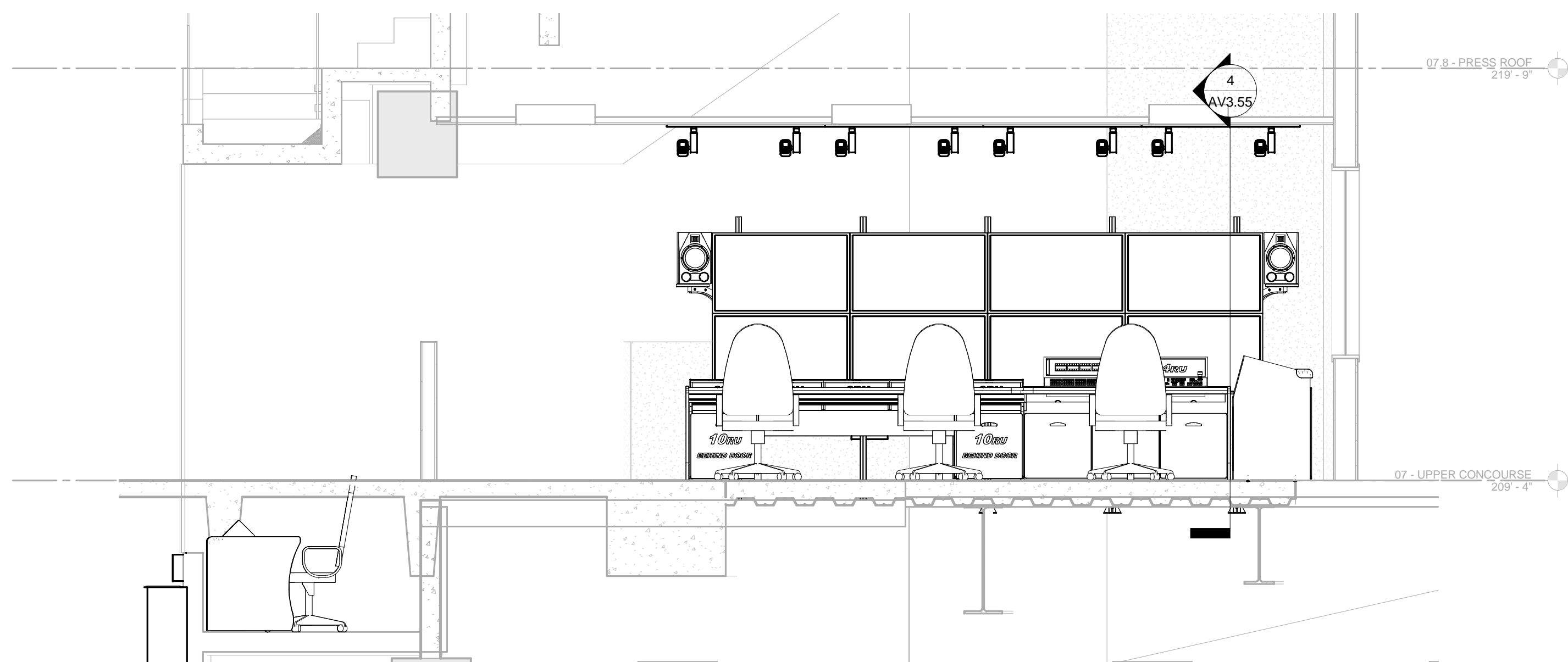

1 PCR Front Row Elevation
3/8" = 1'-0"

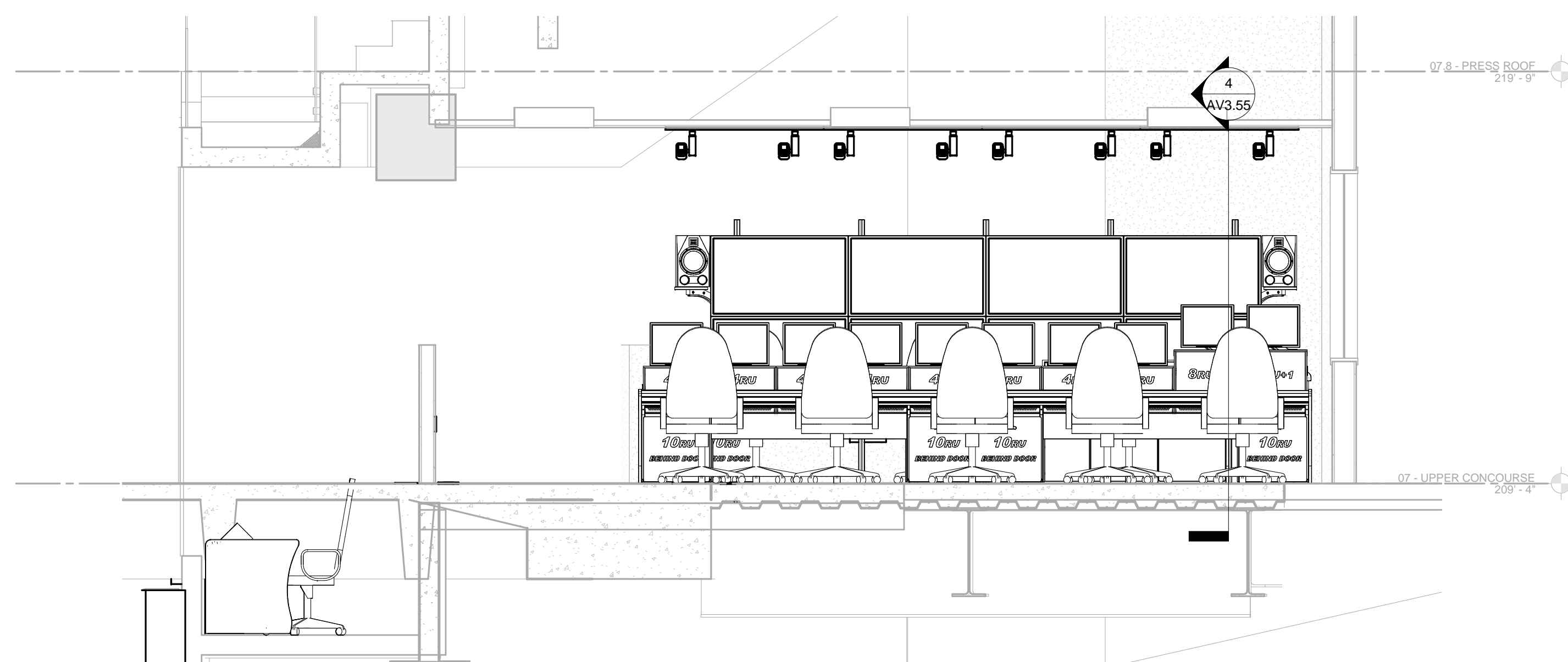

2 PCR Middle Row Elevation
3/8" = 1'-0"

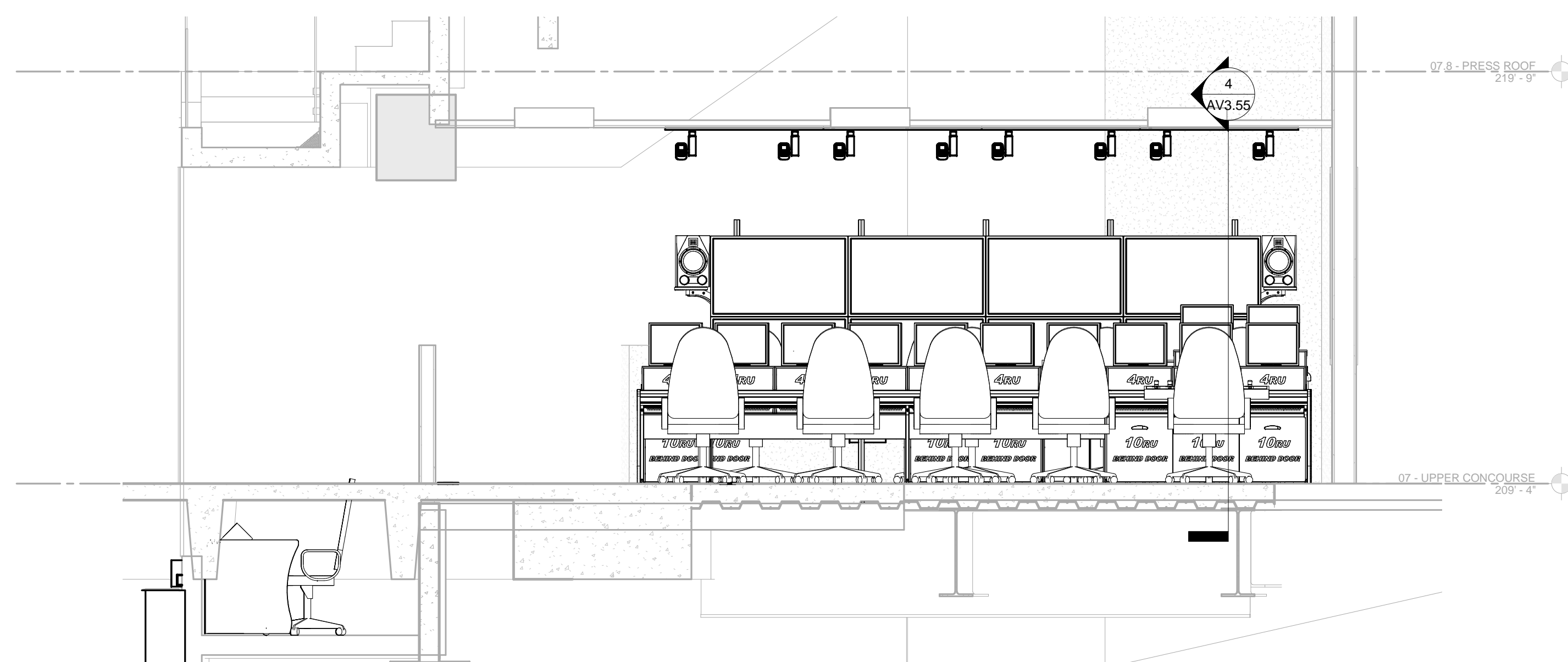

3 PCR Back Row Elevation
3/8" = 1'-0"

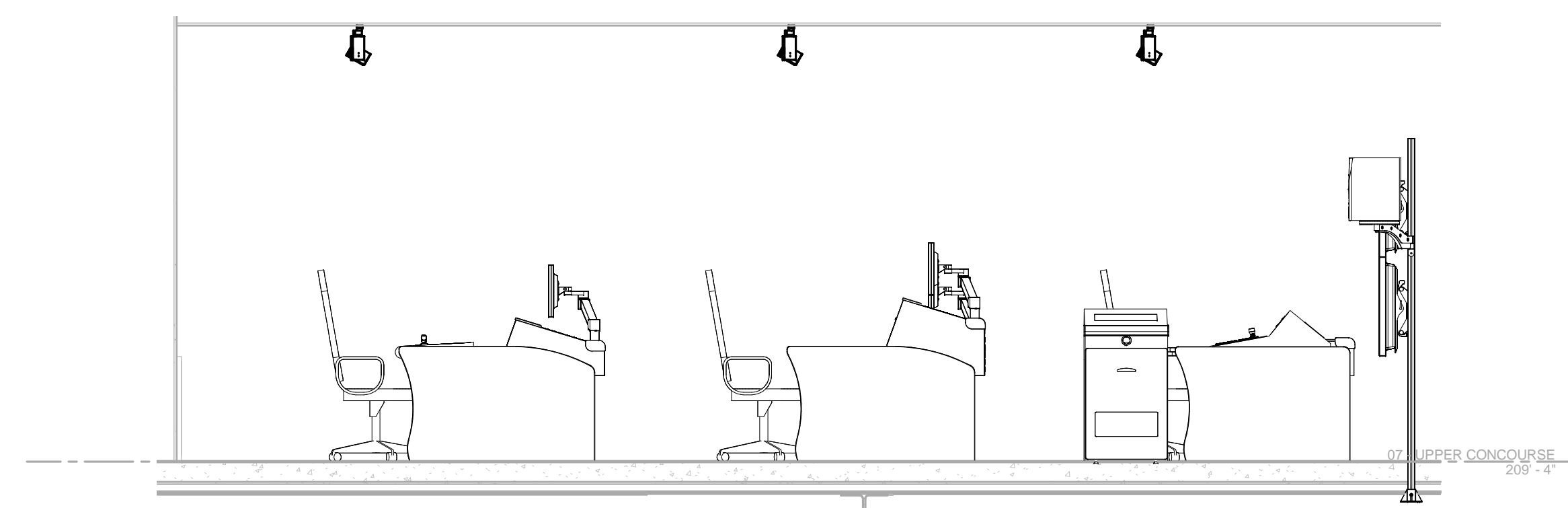

4 PCR Section
3/8" = 1'-0"

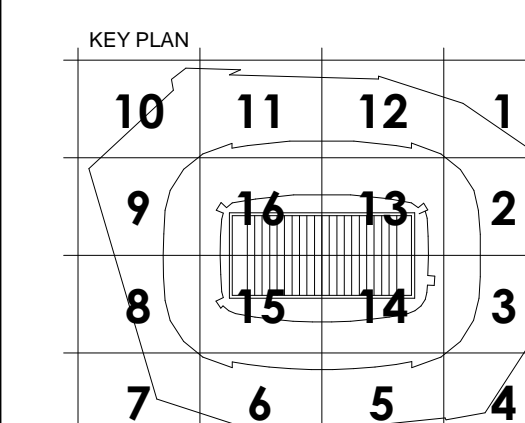
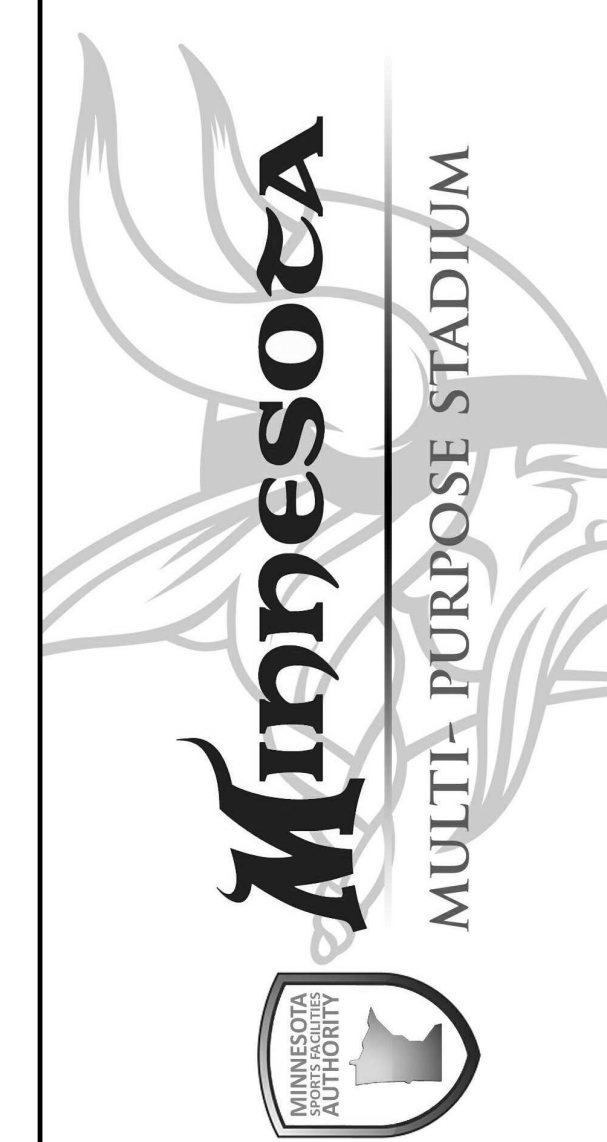

REVISION NO.	DESCRIPTION	DATE

HKS PROJECT NUMBER
16246.000

DATE
MAY 2, 2014

ISSUE
CCD-060

SHEET TITLE
Production Control Room Elevations

SHEET NO.
AV3.55

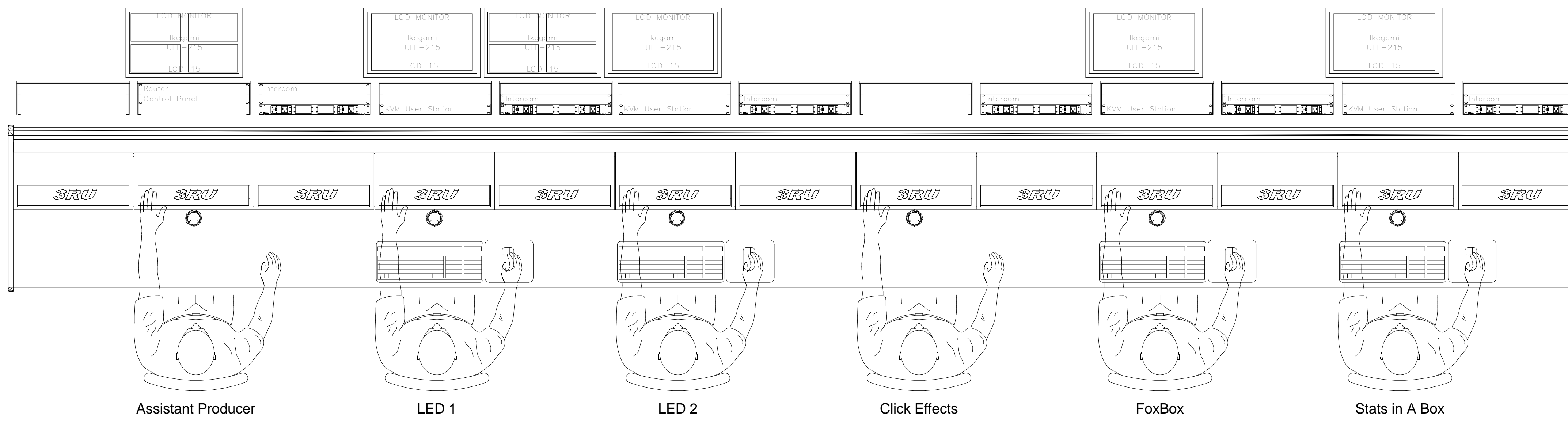

1 FIELD VIEW CONSOLE (LEFT)

Scale: 1" = 1'-0"

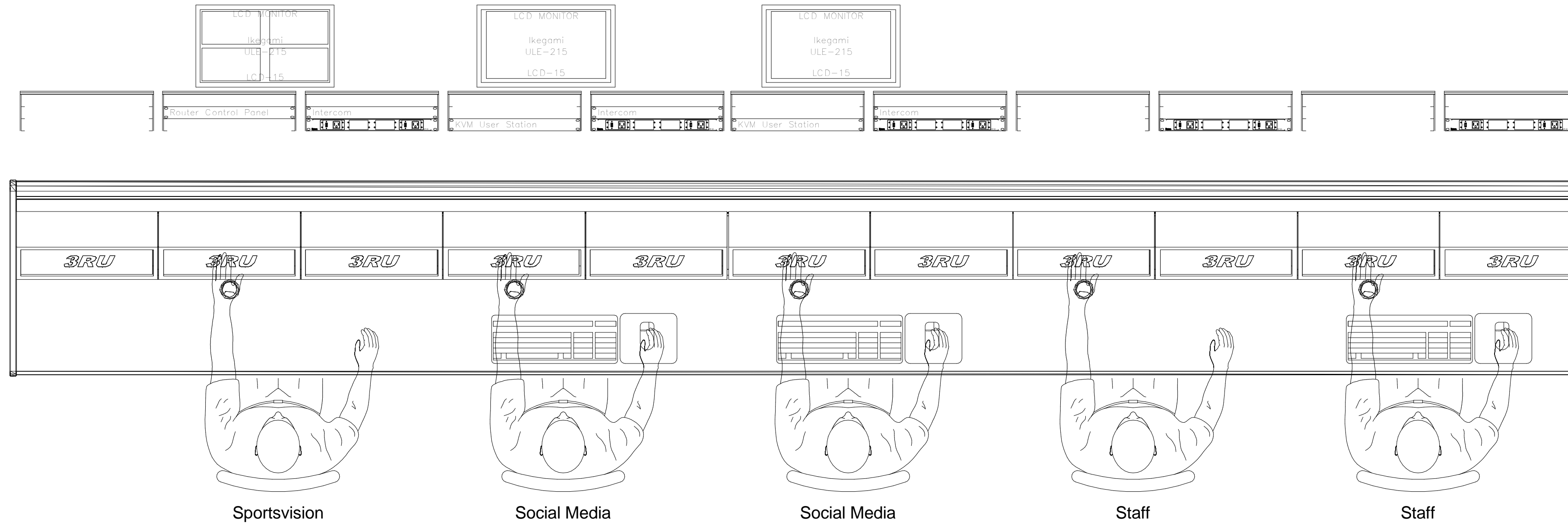

2 FIELD VIEW CONSOLE (CENTER)

Scale: 1" = 1'-0"

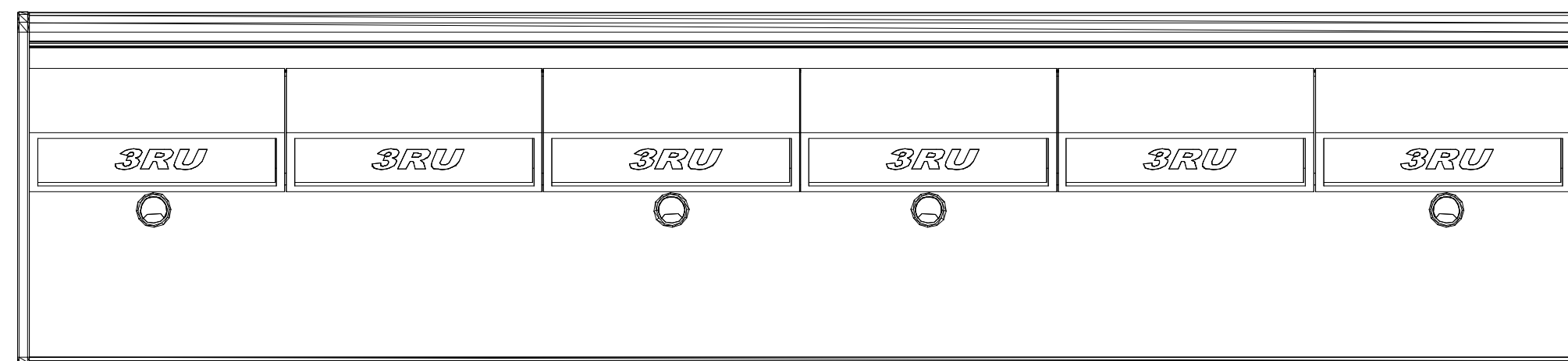

3 FIELD VIEW CONSOLE (RIGHT)

Scale: 1" = 1'-0"

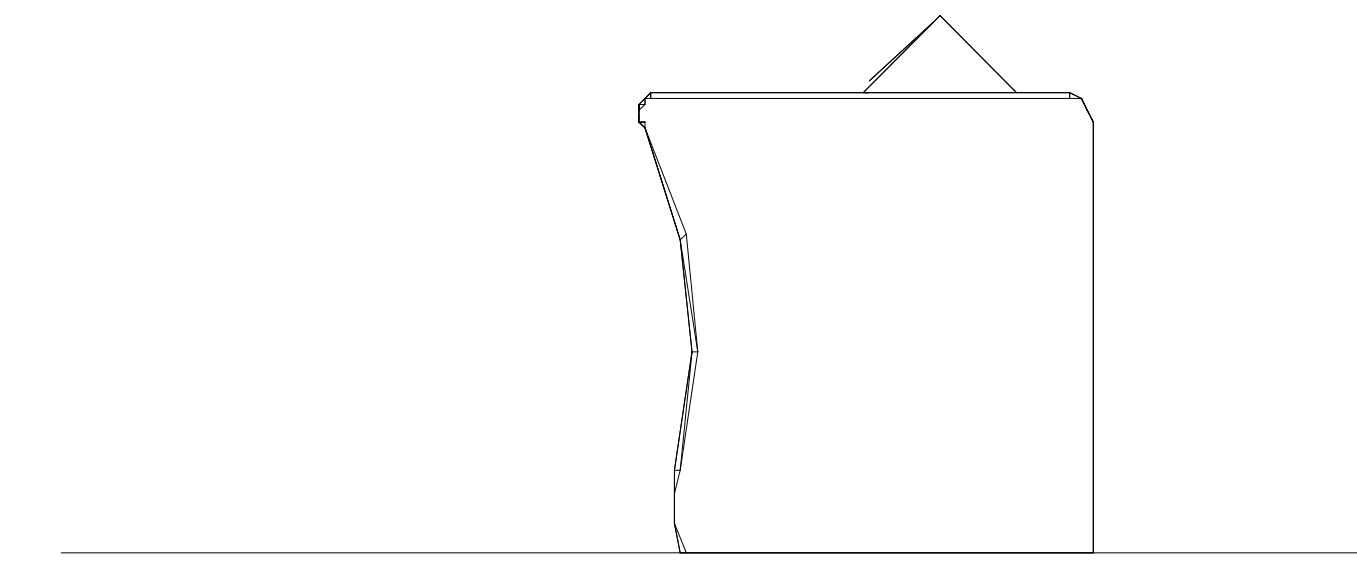
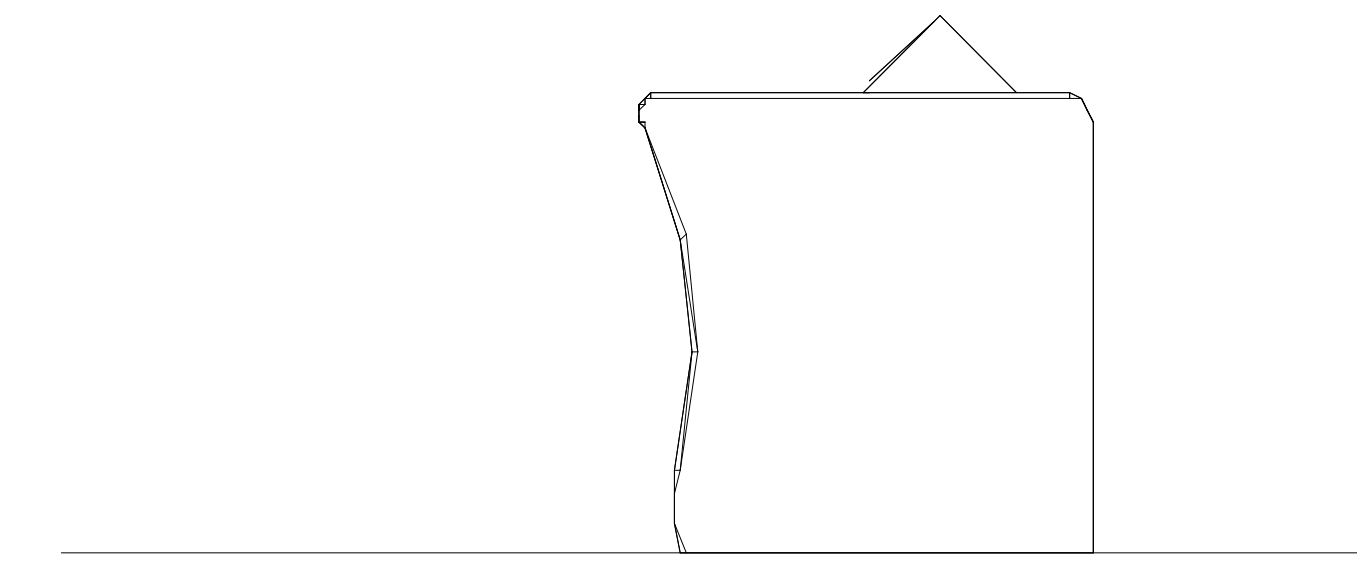
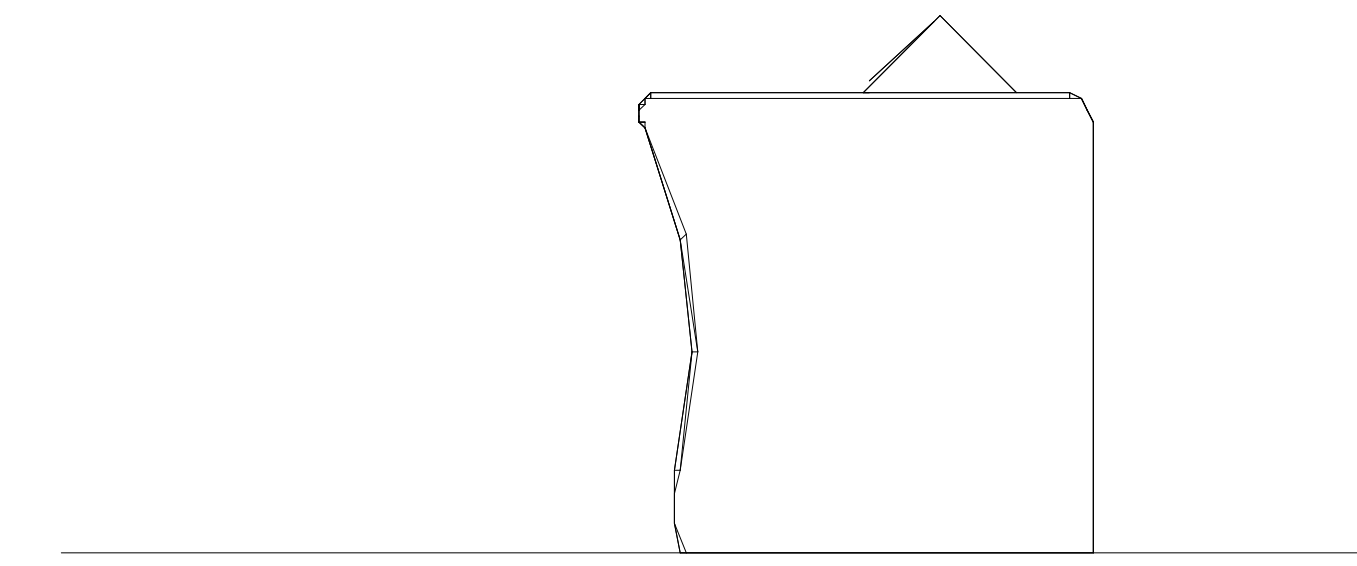

NOT FOR CONSTRUCTION



OWNER
MINNESOTA SPORTS FACILITIES AUTHORITY
800 SOUTH 5th STREET, MINNEAPOLIS, MN 55415

OWNER
MINNESOTA WINGS FOOTBALL, LLC
5600 VIKING DR., EDEN PRAIRIE, MN 55344

ARCHITECT / INTERIORS / BRANDING
HKS, INC.
501 N. ST. PAUL, ST., SUITE 100, DALLAS, TX 75201

ASSOCIATE ARCHITECT - SKIN
STUDIO FIVE ARCHITECTS
322 FIRST AVE. N. SUITE 400, MINNEAPOLIS, MN 55401

ASSOCIATE ARCHITECT - INTERIORS
STUDIO HVF
901 NORTH 5th ST., SUITE 228, MINNEAPOLIS, MN 55401

MEP / TECHNOLOGY / LIGHTING
M.E. ENGINEERS, INC.
10555 WEST 43rd AVE., WHEAT RIDGE, CO 80033

STRUCTURAL ENGINEER
THORNTON TOMASETTI
12750 MERIT DR., SUITE 750, DALLAS, TX 75251

CIVIL ENGINEER
EVS, INC.
10250 VALLEY VIEW, SUITE 123, EDEN PRAIRIE, MN 55344

LANDSCAPE ARCHITECT
OSLUND AND ASSOCIATES
115 WASHINGTON AVE. N., MINNEAPOLIS, MN 55401

AUDIO VISUAL CONSULTANTS
ACOUSTIC DIMENSIONS
15008 WRIGHT BROTHERS DR., ADDISON, TX 75001

WJHW
4801 SPRING VALLEY RD., DALLAS, TX 75244

CODE / FIRE PROTECTION
FSC, INC.
9225 INDIAN CREEK, SUITE 300, OVERLAND PARK, KS 66210

FOOD SERVICE
RICCA NEWMARK
5235 SOUTH VALENTIA, GREENWOOD VLG, CO 80111

WAYFINDING
SELECT PERKINS DESIGN
432 CULVER BLVD., PLAYA DEL REY, CA 90293

VERTICAL TRANSPORTATION
ELEVATOR ADVISORY GROUP
14530 PENNOCOCK AVE., SAINT PAUL, MN 55124

ADA CONSULTANT
ED ROTHER CONSULTING, LLC
2290 MISSION BELLEVIEW, LOUISBURG, KS 66663

WIND / SNOW CONSULTANT
ROWAN, WILLIAMS, DAVIES, AND IRWIN, INC.
600 WOODLAWN RD. W., GUELPH, ON CANADA N1K 1B8

BUILDING ENVELOPE CONSULTANT
THORNTON TOMASETTI - BUILDING SKIN PRACTICE
300 N. WABASH AVE., SUITE 1500, CHICAGO, IL 60611

FAÇADE ACCESS CONSULTANT
LEIGH BATES, INC.
8089 LINCOLN ST., SUITE 105, LITTLETON, CO 80122



INTERIM REVIEW ONLY
These documents are incomplete, and are released for interim review only and are not intended for regulatory approval, permit, or construction purposes.

ACOUSTIC DIMENSIONS, LP IS MANAGED BY IDIBEL, INC.

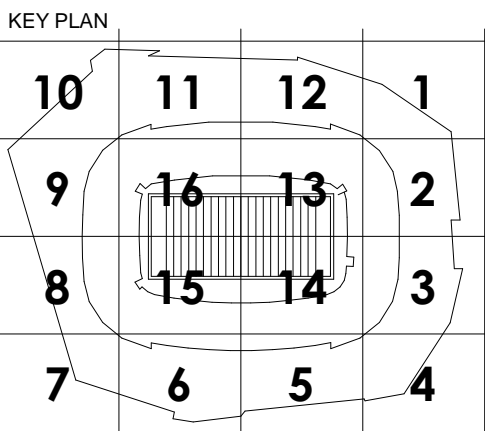

REVISION NO.	DESCRIPTION	DATE

HKS PROJECT NUMBER
16246.000

DATE
MAY 2, 2014

ISSUE
CCD-060

SHEET TITLE
Field View Consoles

SHEET NO.
AV5.54

